

HS-600

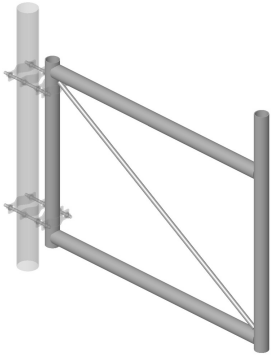

Stand-Off Bracket, heavy duty, 72 in, includes pipe

Product Classification

Product Type Stand-off mount

General Specifications

Mounting Tower member
Note One 72 in x 8 in panel antenna per sector
Pipe, quantity 1

Dimensions

Height 42 in | 1,066.8 mm
Width 3 in | 76.2 mm
Length 72 in | 1,828.8 mm
Pipe Length 42 in | 1,066.8 mm
Pipe Outer Diameter 2.9 in | 73.66 mm
Stand-off Distance 72 in | 1,828.8 mm

HS-600

Outline Drawing

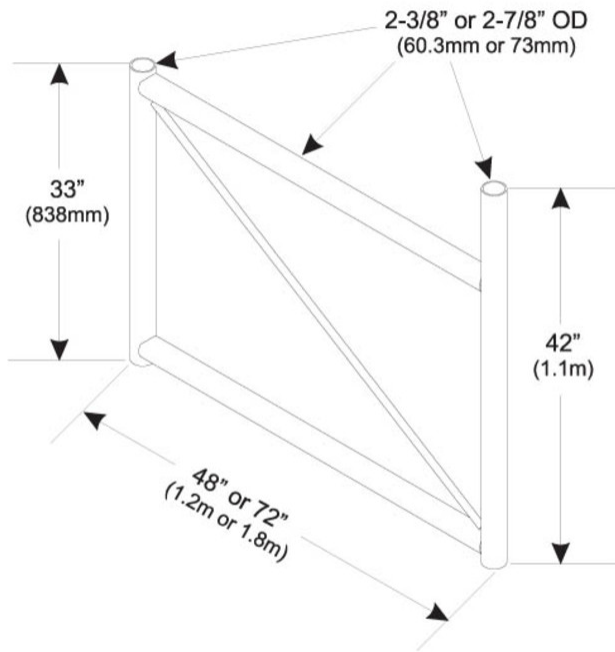

Material Specifications

Material Type Hot dip galvanized steel

Mechanical Specifications

Wind Rating 120 mph (BWS) at 150 ft AGL

Wind Rating Test Method TIA/EIA-222

Packaging and Weights

Included Stand-off

Packaging quantity 1

HS-600

Weight, net 48.7 kg | 107.365 lb

Regulatory Compliance/Certifications

Agency

ISO 9001:2015



Classification

Designed, manufactured and/or distributed under this quality management system

* Footnotes

Wind Rating

BWS—Base Wind Speed; FBC—Florida Building Code