

NOTES:

REVISIONS			
REV.	DESCRIPTION	DATE	APPROVED
A	ECR 8000028353: REL TO PRODUCTION PER EAO 605060.	07FEB18 HWW	SHINE/PJ
B	ECR 8000036580: UPDATE DRAWING WITH LATEST MODEL.	29JUL19 CMY	ZHWJ/REX
C	ECR 8000039431: UPDATE DRAWING WITH LATEST MODEL.	28FEB20 PL	YP/RLX

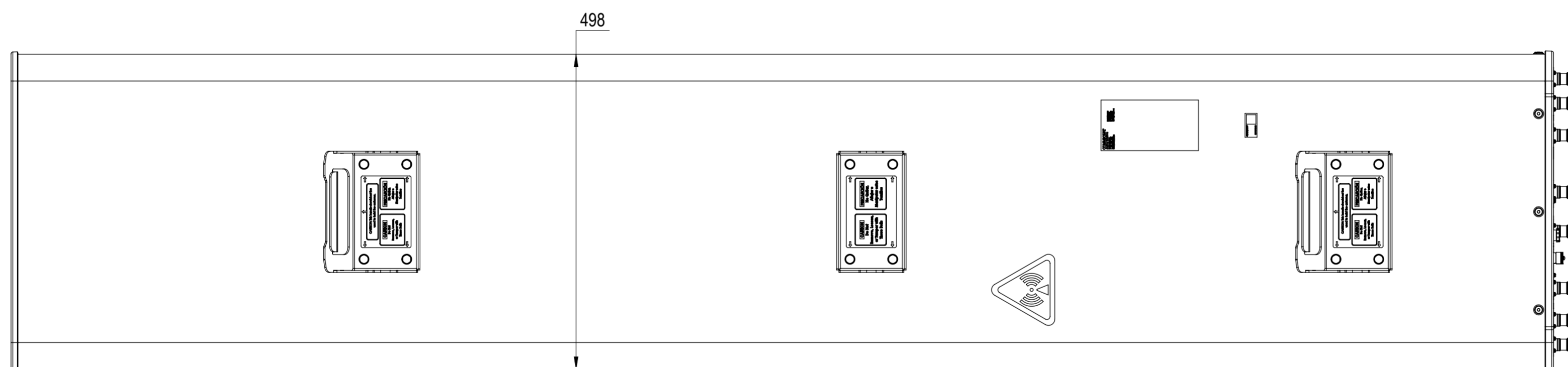
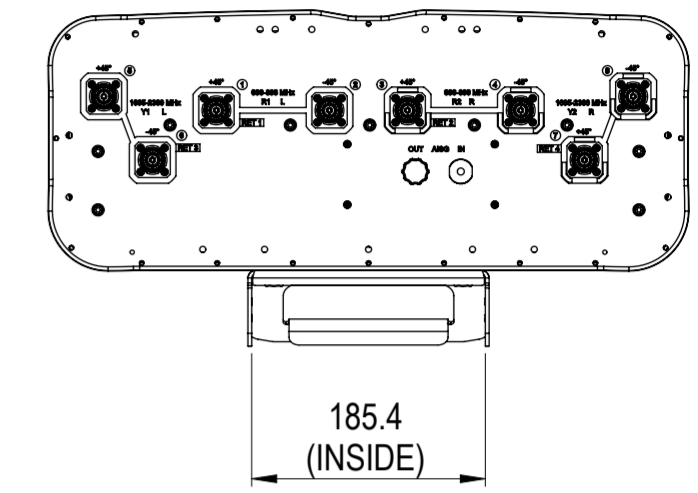
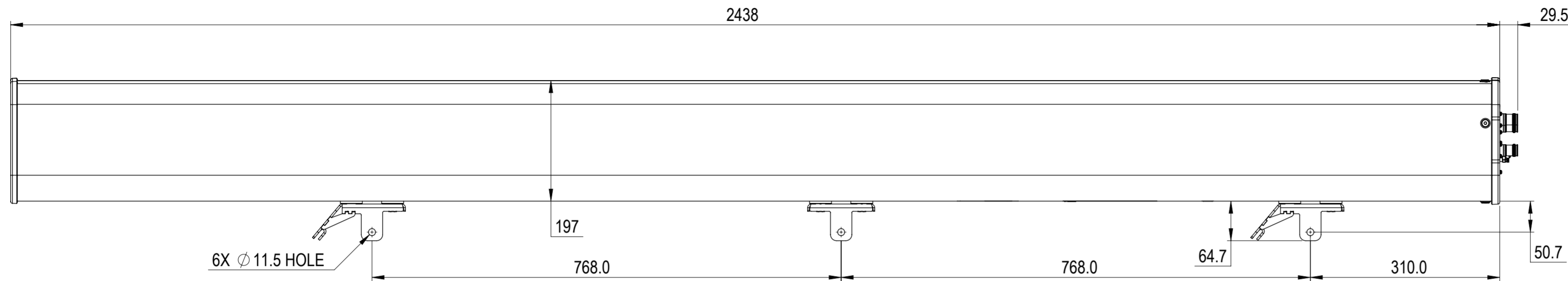

NNHH-65C-R4-V1

COMMSCOPE, INC. OF NORTH CAROLINA

TOLERANCES		SAP MATERIAL MASTER										
0 PLACE X ±	2 PLACE .XX ±											
1 PLACE .X ±	ANGLES ±											
FINISH		MATERIAL										
<small>UNLESS OTHERWISE SPECIFIED DIMENSIONS ARE IN MILLIMETERS INTERPRET PER ISO STANDARDS HANDBOOK TECHNICAL DRAWINGS VOLUMES 1 & 2, THIRD EDITION (2002)</small>		NAME	DATE									
		CE WH1029	02/07/2018									
		RW PL1051	02/28/2020									
		RV HDTANG	02/28/2020									
		AD LR1057	02/28/2020									
RE BYUAN	02/28/2020	ECN 8000039431-O										
SCALE		DOCUMENT NO.										
1:6		NNHH-65C-R4-V1-L										
SIZE	WORK AREA	23	MODEL									
A2			<table border="1"> <tr> <th colspan="3">DRAWING</th> </tr> <tr> <th>VERSION</th> <th>STATUS</th> <th>REVISION</th> </tr> <tr> <td>04</td> <td>RE</td> <td>E</td> </tr> </table>	DRAWING			VERSION	STATUS	REVISION	04	RE	E
DRAWING												
VERSION	STATUS	REVISION										
04	RE	E										
HEIGHT			LENGTH									
LENGTH			WIDTH									
WIDTH												
			SHEET									
			1 OF 1									