

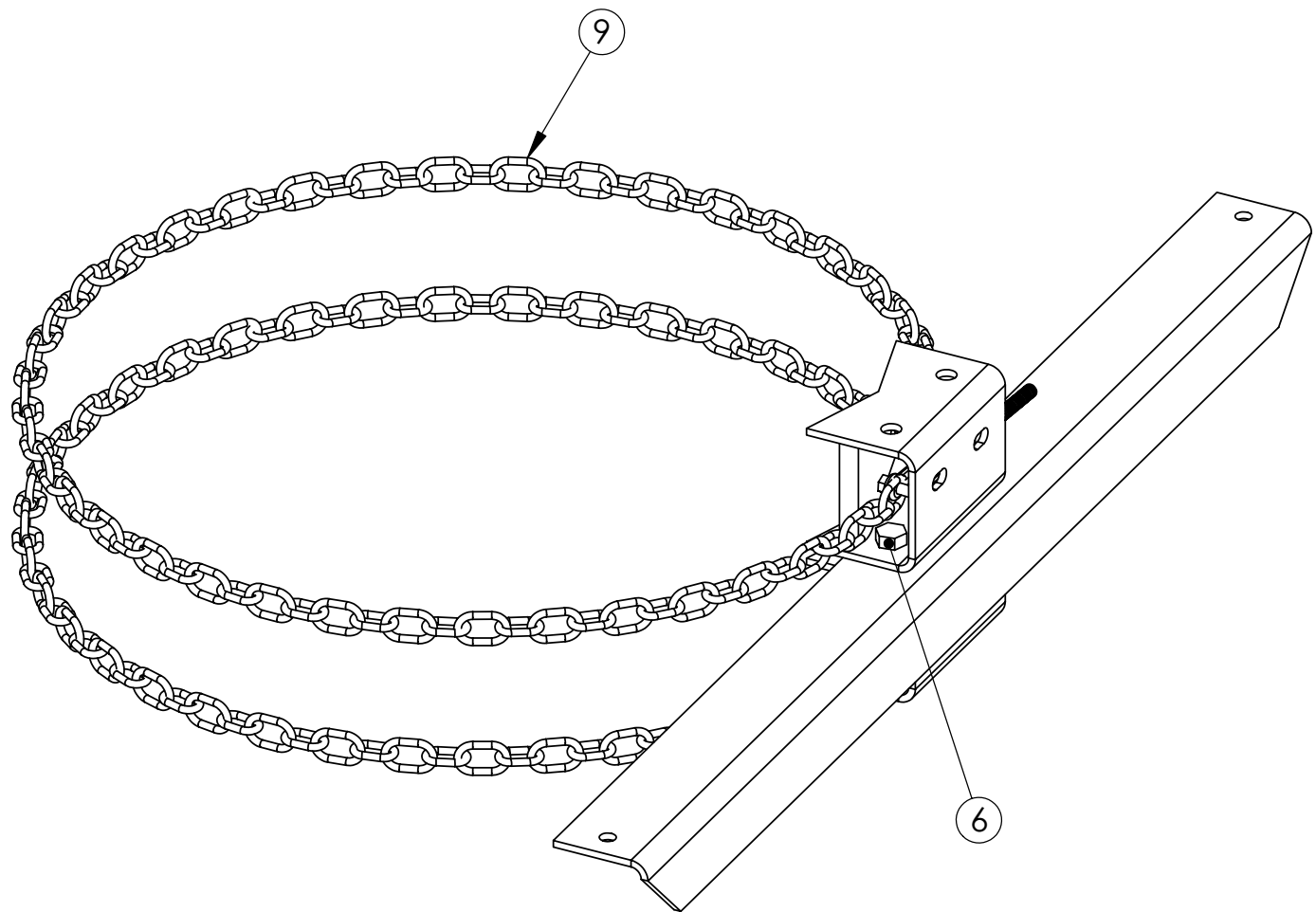

ITEM	PART NO.	DESCRIPTION	QTY.	WEIGHT
1	CMSL.01	CHAIN MOUNT STIFF ARM ANGLE	1	20.10 LBS
2	CMSH60H	HARDWARE KIT (ITEMS 3 THRU 9)	1	
3	CM.01	CHAINMOUNT ANCOR	2	5.95 LBS
4	CM.03	CHAIN LOCK	2	0.27 LBS
5	CM.04	1/2" RIGHT HAND THREAD JAW	2	0.58 LBS
6	GB-0516A	5/8" X 1-3/4" GALV BOLT KIT (A325)	2	0.25 LBS
7	GWL-04	1/2" GALV LOCK WASHER	1	0.01 LBS
8	GN-04	1/2" GALV HEX NUT (C2)	1	0.04 LBS
9	G4-0-192	G-40 CHAIN 16ft	2	12.00 LBS

REVISIONS				
REV.	ZONE	DESCRIPTION	BY	DATE
A		INITIAL RELEASE	AW	09/21/04
B		UPDATED BOM	AW	08/14/06

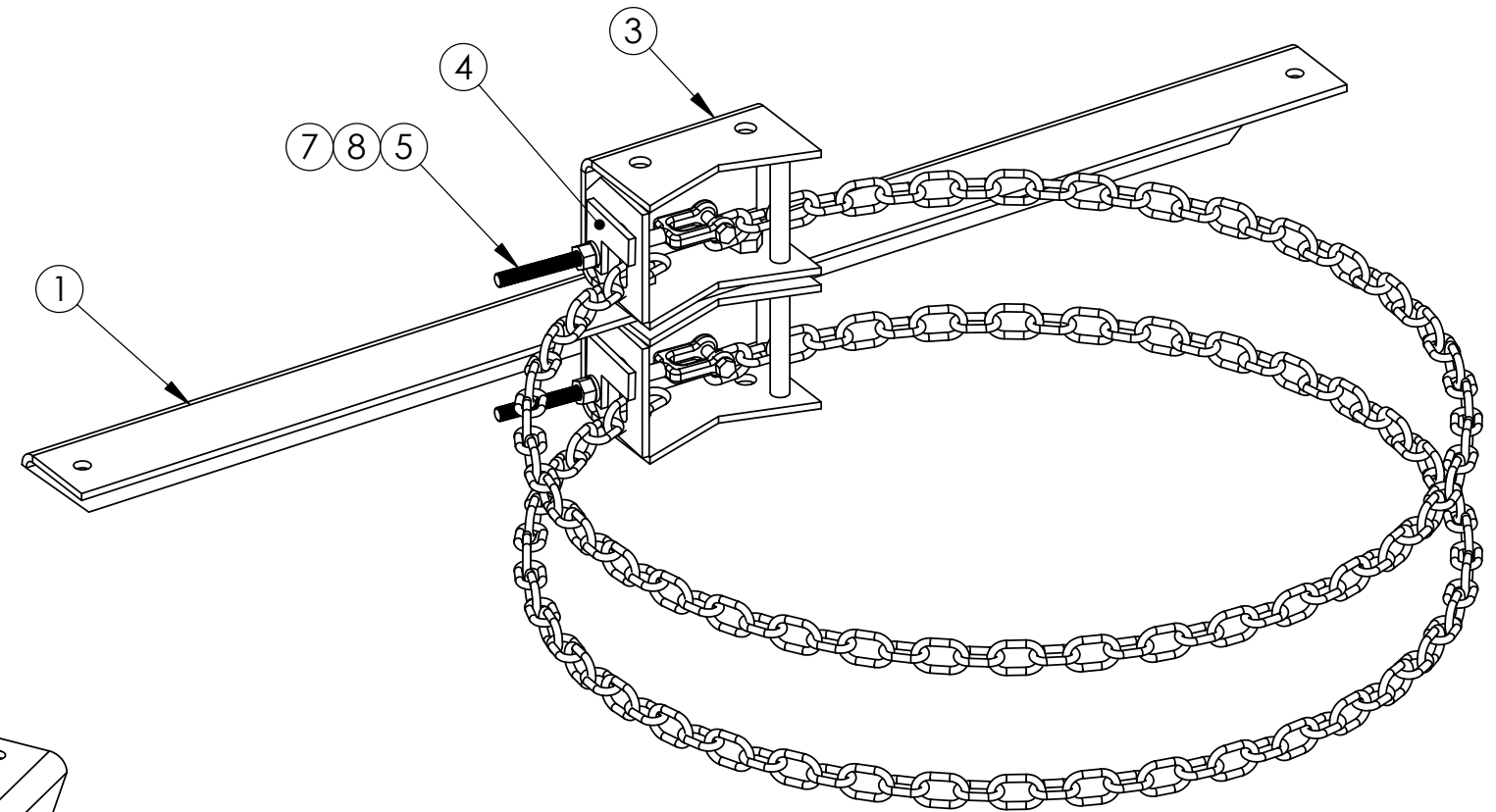

<small>These drawings and specifications are the proprietary property of ANDREW CORPORATION and may be used only for the specific purpose authorized in writing by Andrew Corporation.</small> ALL DIMENSIONS ARE IN INCHES U.O.S. TOLERANCES UNLESS OTHERWISE SPECIFIED: .X = .06 ANGLES 2' .XX = .03 FRACTIONS 1/32 .XXX = .010 REMOVE BURRS AND BREAK EDGES .005 DO NOT SCALE THIS PRINT	DRAWN BY: AW	SHEET: 1 of 1	PART NUMBER: CM-SH60 SERIES
	CHECKED BY: TP	SCALE: NTS	DESCRIPTION: CHAINMOUNT-STIFF ARM
	DATE: 9/21/04	MATERIAL: A36	DRAWING TYPE: ASSEMBLY DRAWING
	REVISION: B	FINISH: GALV WEIGHT: 62.00 LBS	 ANDREW ®

ORLAND PARK, IL. 60462
U.S.A.