

M-LOC Bird proof Jumper Assembly

for HELIAX® M-LOC series Patent Pending

Bulletin 7850506 Revision D Page 1 of 4

1 Remove any packaging and dust caps from the M-LOC and the device, uncoil the M-LOC assembly. Hold the bent flange portion of latch back toward cable strain relief.

Stainless steel band may have sharp edge, gloves recommended

2 Align the key on the housing with the keyway opening in the device. Orient the holes in the M-LOC connector to the panel mount connectors.

Housing Alignment Key

Keyway

M-LOC

Device

3 Align the M-LOC connector with the antenna mating interface and push firmly into place, eliminating gap between connector housing and bulkhead. While mating, a slight back and forth motion on the housing/ cables will assist in centering and seating the port connectors into alignment. **Do Not** twist the jumpers. Push the latch toward the base of the antenna to engage the latch pins at the base of the connector housing.

Confirm latch pins on both sides are engaged

4 Apply force on the bent flange of the latch until the detents in the arms pop over the pins. There will be an audible and tactile click. To reduce hand strain, a screwdriver may be used.

250 mm (9.84 in)

Keep 250 mm (9.84 in) length straight before routing to the device. First hanger should be located within 0.5 meter (19.6 inches).

5 To remove the M-LOC connector pull latch flange away from the base of the antenna. To reduce hand strain, a flat blade screwdriver may be inserted in the slot above the latch flange and pulled down against the flange.

Slot

6 Grasp M-LOC connector housing, hold bent flange portion of latch back toward cable strain relief, pull the connector away from device. A slight back and forth motion on the housing helps to release the port connectors.

M-LOC Bird proof Jumper Assembly
for HELIAX® M-LOC series Patent Pending

7 Route and form the jumper assembly with HELIAX® SureGuard weatherproofing system installed prior to attaching the coupling nuts.

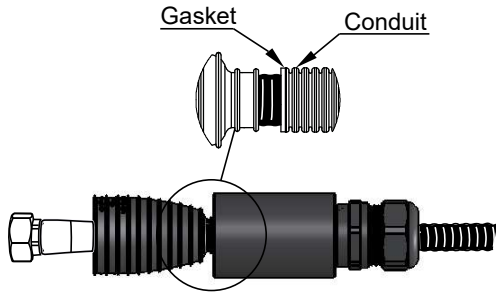

8 Torque the connection using the appropriate wrenches or tool.
7-16 DIN male connector: 25-30 N•m (18-22 ft-lb)
4.3-10 male connector: 5-8 N•m (4-6 ft-lb)
NEX10 male connector: 1.5 N•m (1.1 ft-lb)

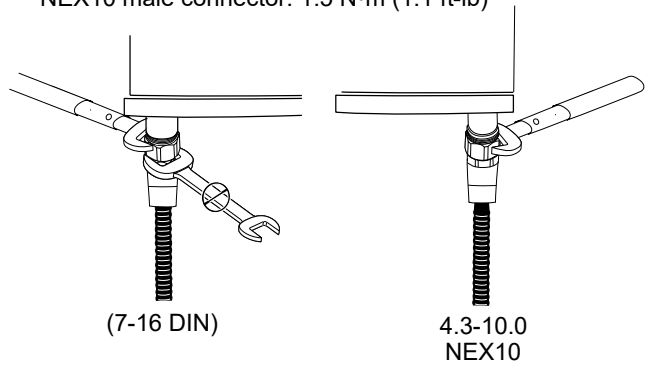

9 Push **1** and twist **2** the boot **counter-clockwise** over the male coupling nut. Pull down slightly **3** and push back up **4** to flatten the top of the boot. Boot **MUST** look like Properly Seated illustrations below.

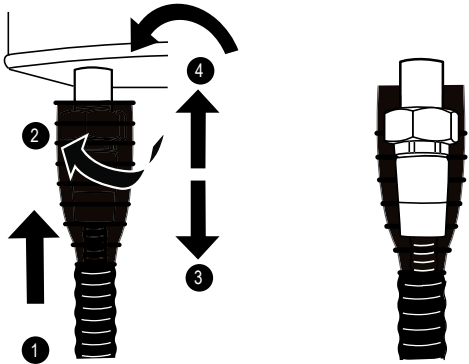

10 Pull back conduit with gasket through the picture direction shown stopped by sureguard V2.0. Make sure the gasket is seated well into the conduit.

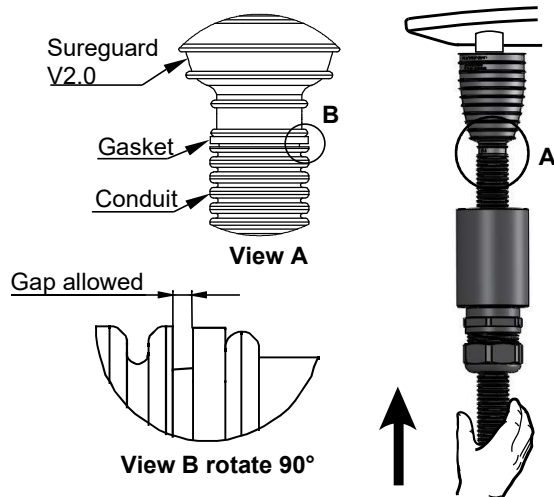

Suregard V2.0 boot should not be pushed up over the square section of the connector.
Be careful only tighten the cable gland nut after all cable fastening and movement is completed.

M-LOC Bird proof Jumper Assembly
for HELIAX® M-LOC series Patent Pending

11 Push cap to cover sureguard V2.0 in, keep the cap as line as sureguard.

Cap
Sureguard V2.0

12 Screwed cable gland nut by hand as shown.

WARNING
Be careful cable gland nut must be fasten on the conduit.
No gap allowed

13 Do not hold the connector and bend the cable directly behind it, start bend 30mm min away from the cap end as picture shown.

R50mm min
30mm min

REWORK:
Pull back gasket along with conduit, then pull back sureguard V2.0

For jumper assemblies without sureguard boots applying weather proofing to 4.3-10 assemblies is recommended (contractor supplied).

X1
X3
X1

Wrap one layer of insulation tape
Wrap three layers of waterproof tape
Wrap one layer of insulation tape

See page 3 for Reversing Latch Orientation

1 The latch orientation is reversible if required.

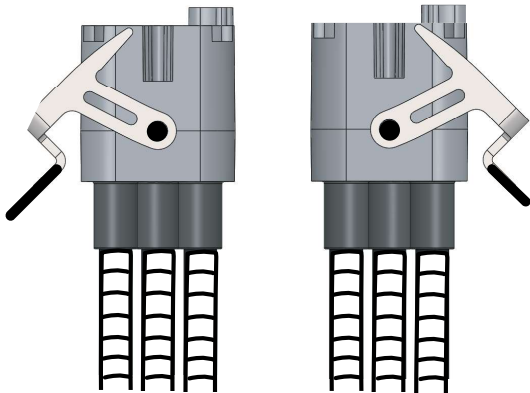

2 Align the hole of the latch arm with the hinge pin of the connector body and pull gently away from the body, just enough to clear the end of the hinge pin. Then pull the latch arm away parallel to the body

⚠️ Ensure that the arm doesn't get caught on the retention groove or damage may occur to the hinge pins.

Roll the latch around and off the opposite pin.

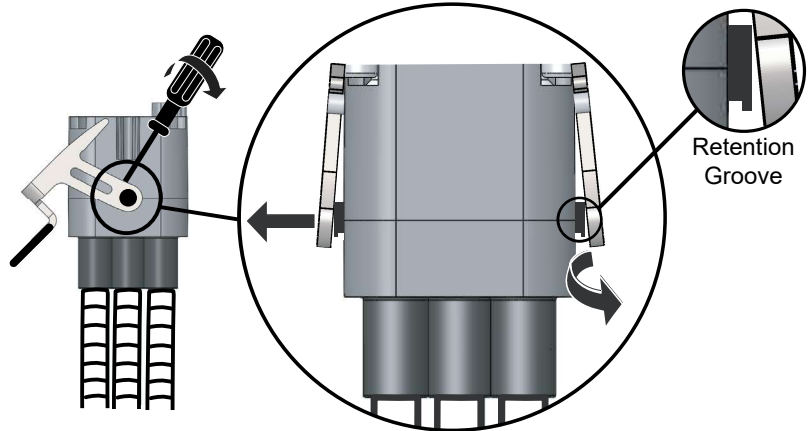

3 Once the latch is removed, bend the two arms back to 90° so they will fit tightly back onto the housing. To reattach, latch one arm over a hinge pin then roll other arm over the housing and onto the other hinge pin.

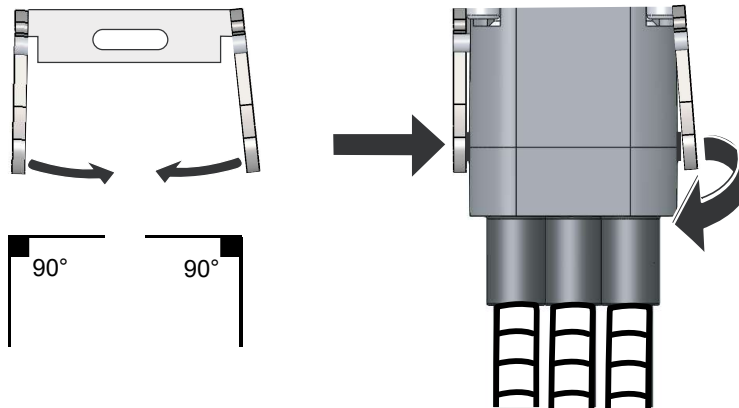

M-LOC cluster connector bottom installation video



M-LOC cluster connector back installation video

CommScope
1100 CommScope Place SE P.O. Box 339, Hickory, NC 28603-0339
(828) 324-2200 (800) 982-1708
www.commscope.com

Technical Support
+1 888 297 6433, Option 3 (Toll Free US and Canada)
+1 49-9099-69-333
<https://www.commscope.com/wisupport> (open a ticket)

Notice: CommScope disclaims any liability or responsibility for the results of improper or unsafe installation, inspection, maintenance, or removal practices.
Aviso: CommScope no acepta ninguna obligación ni responsabilidad como resultado de prácticas incorrectas o peligrosas de instalación, inspección, mantenimiento o retiro.
Avis: CommScope décline toute responsabilité pour les conséquences de procédures d'installation, d'inspection, d'entretien ou de retrait incorrectes ou dangereuses.
Hinweis: CommScope lehnt jede Haftung oder Verantwortung für Schäden ab, die aufgrund unsachgemäßer Installation, Überprüfung, Wartung oder Demontage auftreten.
Atenção: A CommScope abdica do direito de toda responsabilidade pelos resultados de práticas inadequadas e sem segurança de instalação, inspeção, manutenção ou remoção.
Avvertenza: CommScope declina eventuali responsabilità derivanti dall'esecuzione di procedure di installazione, ispezione, manutenzione e smontaggio improprie o poco sicure.
注意: CommScope 公司申明對於不恰當或不安全的安裝、檢驗、維修或拆卸操作所導致的後果不負責任 何義務和責任