

SYSTIMAX 360™ 1100GS3 and 1100GS6 Evolve Modular Panel Instructions

General

The **SYSTIMAX 360™** 1100GS3 (Cat 6) and 1100GS6 (Cat 6A) Evolve modular panels exceed ISO and TIA Performance Category standards. The performance category is identified by the color of the jacks. Jacks with gray jack housings are Category 6A (GS6) and jacks with black jack housings are Category 6 (GS3). The **SYSTIMAX 360** 1100GS3 (Cat 6) and 1100GS6 (Cat 6A) Evolve modular panels and can be used for EIA-T568A or EIA-T568B wiring applications and are available in 24-port and 48-port flat and angled versions.

SYSTIMAX 360 InstaPATCH® fiber modules can be used in the 1100GS 24-port and 48-port flat panels when the separately orderable Evolve fiber bezels, rear cable management bar, and front cable trough are utilized.

The 1100GS Evolve panels are available **iPatch®** ready. For instructions on using panels in an **iPatch** application, see 860516491 **iPatch® Upgrade Module Instructions for SYSTIMAX 360 Panels**.

Panel kits are available unpopulated for use with separately ordered modules.

Ordering information for modular panels is listed below:

360 GS3 Modular Panels		360 GS6 Modular Panels	
Material ID	Description	Material ID	Description
760152561	1100GS3 Evolve 24-port flat panel	760152587	1100GS6 Evolve 24-port flat panel
760152579	1100GS3 Evolve 48-port flat panel	760152595	1100GS6 Evolve 48-port flat panel
760151308	1100GS3 Evolve 24-port angled panel	760151324	1100GS6 Evolve 24-port angled panel
760151753	1100GS3 Evolve 48-port angled panel	760151779	1100GS6 Evolve 48-port angled panel

Ordering information for panel kits is listed below:

360 Flat Panel Kits*		360 Angled Panel Kits*	
Material ID	Description	Material ID	Description
760155739	1100GS Evolve 24-port flat panel kit	760152785	1100GS Evolve 24-port angled panel kit
760155747	1100GS Evolve 48-port flat panel kit	760152793	1100GS Evolve 48-port angled panel kit

*Modules are not included and must be ordered separately

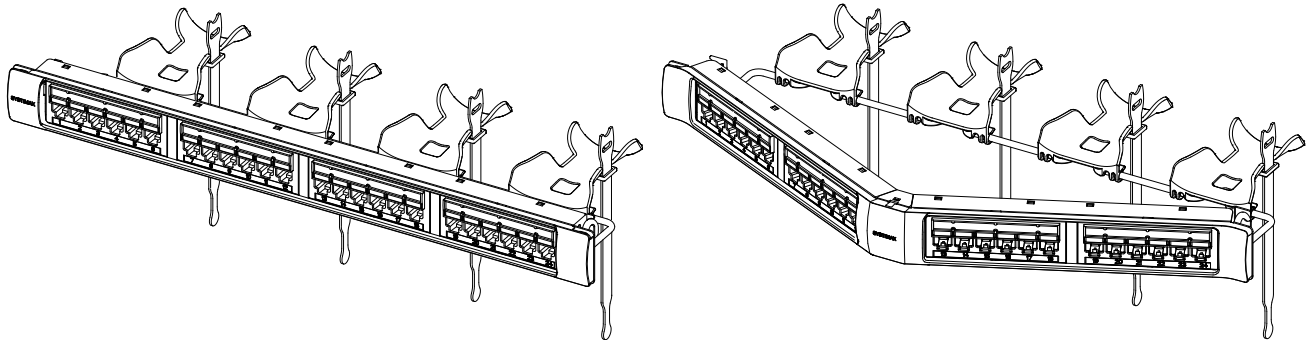

SYSTIMAX 360™ 1100GS Evolve 24-Port Flat Panel and 24-Port Angled Panel

How to Contact Us

- To find out more about **CommScope**® products, visit us on the web at <http://www.commscope.com/>
- For technical assistance:
 - Within the United States, contact your local account representative or technical support at 1-800-344-0223. Outside the United States, contact your local account representative or **PartnerPRO**™ Network Partner.
 - Within the United States, report any missing/damaged parts or any other issues to **CommScope** Customer Claims at 1-866-539-2795 or email to claims@commscope.com. Outside the United States, contact your local account representative or **PartnerPRO** Network Partner.

Tools Required

- Phillips head screwdriver
- Cable jacket scoring tool
- D-914 punch tool with M110 blade

Specifications

Wire Termination

Wire Size:

22-24 AWG (0.64 - 0.51 mm) Solid Copper

22-24 AWG (0.64 - 0.51 mm) Seven Stranded Copper

Insulation Size:

0.042 inch maximum DOD

Insulation Types:

Polyethylene, Polypropylene, and FEP

IDC Reterminations:

20 minimum

Modular Jack Mating Cycles:

750 minimum

Environmental Data

Temperature Range:

-40°F (-40°C) to 158°F (70°C) (Storage)

14°F (-10°C) to 140°F (60°C) (Operational)

Humidity:

95% Noncondensing

Parts List

Verify parts against parts list below:

24-Port Flat Panel	Quantity		48-Port Angled Panel	Description
	48-Port Flat Panel	24-Port Angled Panel		
1	—	—	—	24-port flat panel
—	1	—	—	48-port flat panel
—	—	1	—	24-port angled panel
—	—	—	1	48-port angled panel
1	1	—	—	Front cover (1U or 2U)
—	—	1	1	Center cover (1U or 2U) angled panel
—	—	2	2	Side covers for angled panel (1U or 2U) right and left
4	4	4	4	P12-24 x ½" mounting screws
1	2	1	2	Cable management bar
4	8	4	8	Cable management troughs
4	8	4	8	Hook-and-loop straps
1	2	1	2	Termination manager kit
4	8	4	8	Rear label, T568A wiring *
1	2	1	2	Front label card (4 labels per card)
1	2	1	2	Front label cover card (4 covers per card)
1	1	1	1	Instruction sheet

Note: Panel kits include all the parts listed above with the exception of the termination manager kit(s) and T568A wiring labels. These are provided with the separately ordered distribution modules.

* Not included if module is preinstalled with combined T568A&B wiring designation label.

Separately Orderable Items

Contact your **SYSTIMAX** sales representative for the latest information on the wide variety of **360 InstaPATCH®** modules that are compatible with the fiber bezel.

Distribution modules for the 360 1100GS3/1100GS6 panel kits must be ordered separately and are listed below:

Material ID	Description
760151167	360 1100GS3 Evolve distribution module 6-port kit
760151183	360 1100GS6 Evolve distribution module 6-port kit
760175877	360 1100G2 Evolve fiber bezel, 4-pack, cool grey
760175919	360 1100G2 Evolve rear cable manager
760175893	360 1100G2 Evolve 1U front cable trough
760175901	360 1100G2 Evolve 2U front cable trough

WARNING – Important Safety Instructions

When using this product, the following basic safety precautions should be followed to reduce the risk of fire, electric shock, and injury to persons:

1. Never install communications wiring in wet locations unless it is designed for wet locations.
2. Never install this product during a lightning storm. There is a remote risk of electric shock.
3. Never touch uninsulated communication wiring or terminals unless the communication circuit has been disconnected at the network interface.
4. **Caution:** All wiring that connects to this equipment must meet applicable local and national building codes and network wiring standards for communication cable.

Step 1 – Mount Panel to Rack

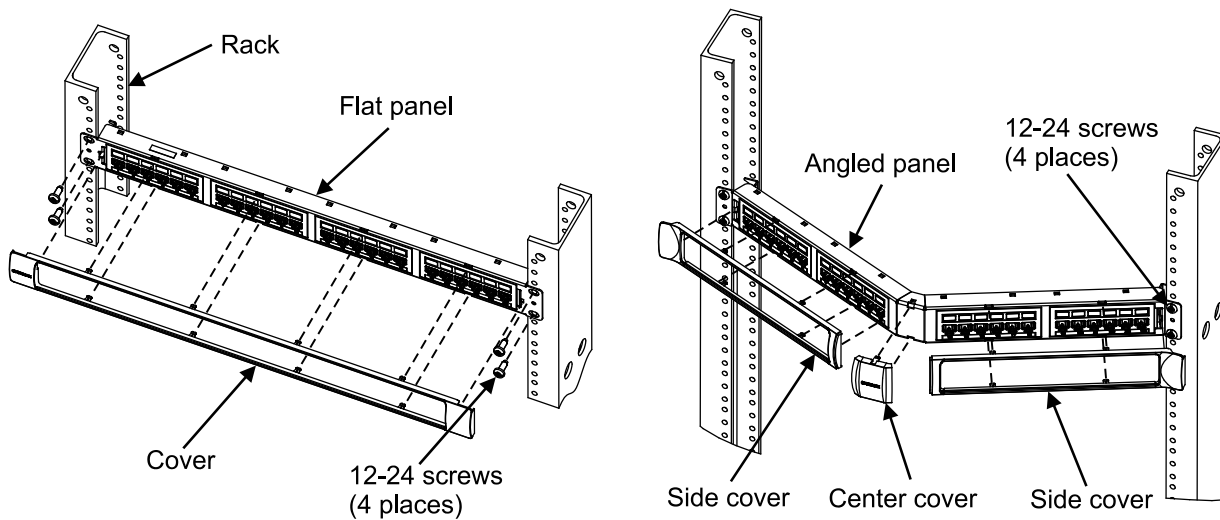

1. Mount panel to rack using the four 12-24 mounting screws provided. After securing panel to rack, snap the Evolve cover(s) onto the front of the panel.

Note: Verify the **SYSTIMAX** name is upright on the flat panel cover and on angled panel center cover before snapping in place. These two covers can be installed upside down. Side covers on angled panel are interchangeable and are not side specific.

Instructions for Installing Copper Components in Panel (See Page 7 for Installing Fiber Components)

Step 2 – Populate Panel with Distribution Modules (For Panel Kits Only)

Note: Distribution modules are ordered separately.

1. From the rear side of the panel, insert the front face of the module into the desired panel opening. Press firmly until both the left and right side module snaps fully engage with the panel. When installing modules in either of the two end positions, it is necessary to engage the outermost snap first.

Step 3 – Terminate Conductors on Rear of Panel

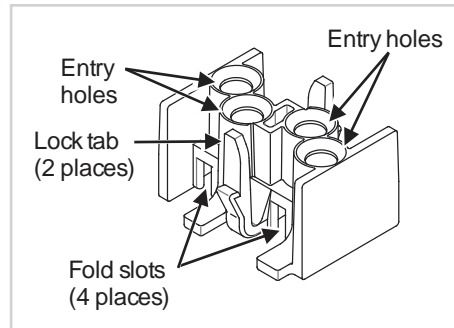
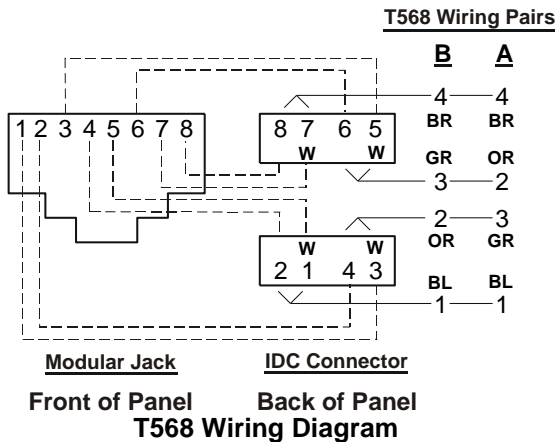

Termination Manager

Note: The module comes with a T568B wiring designation label installed. If T568A wiring is desired, first remove the "B" type label and then place the "A" type label. **Do not place the "A" type label on top of the "B" type label.** If the module comes with a combined T568 A&B wiring designation label installed, choose T568A wiring or T568B wiring according to label designation.

Note: If using **SYSTIMAX GigaSPEED® X10D 91B series cable, 95B series cordage, or Xpress® 88 series cable**, see preparation instructions below.

Note: See pages 10 and 11 for proper use of the termination manager.

1. Prepare cable for IDC termination. Terminate conductors on the IDC terminals per the wiring diagram shown above and utilizing the termination manager.

Preparation of X10D 91B Series Cable, 95B Series Cordage, or Xpress 88 Cable for Termination

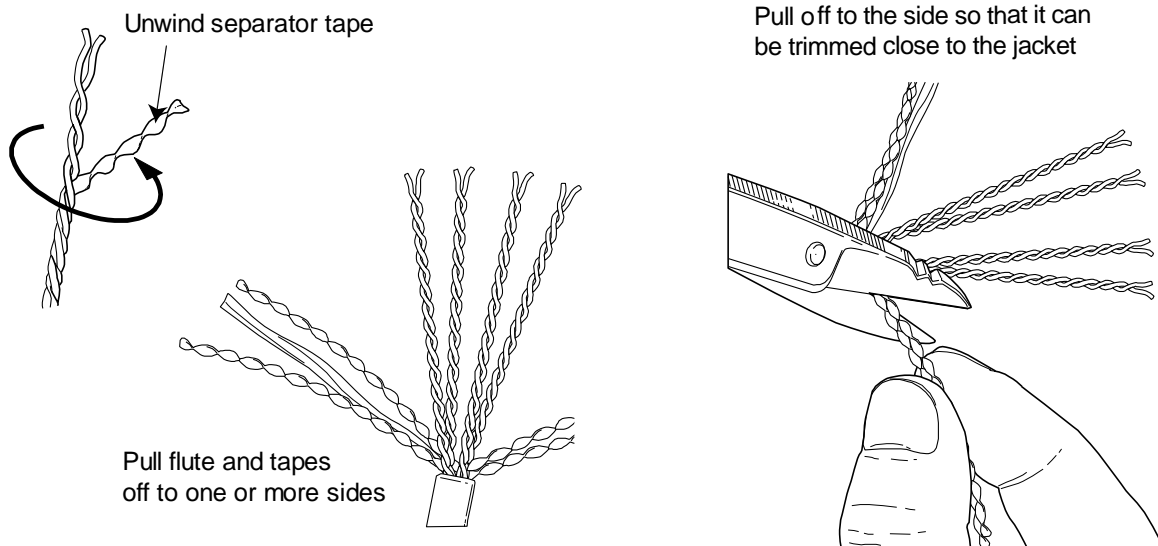

Preparation of the **SYSTIMAX GigaSPEED X10D 91B series cable, 95B series cordage, or Xpress 88 series cable** is shown above. For complete instructions on preparing these cables for termination, see instruction sheet 860469402.

Step 4 – Assemble and Install Rear Cable Manager

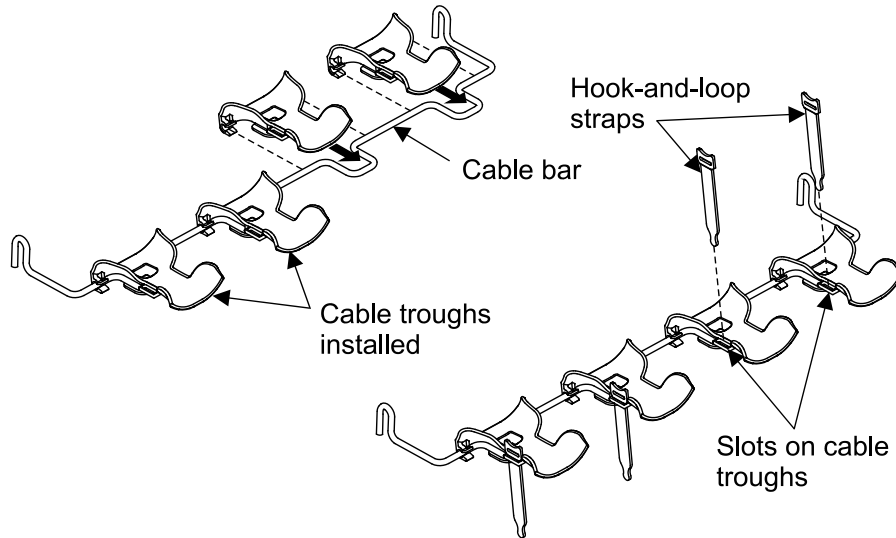

1. Attach the four cable troughs onto bar as shown and insert four hook-and-loop straps into slots in cable troughs.

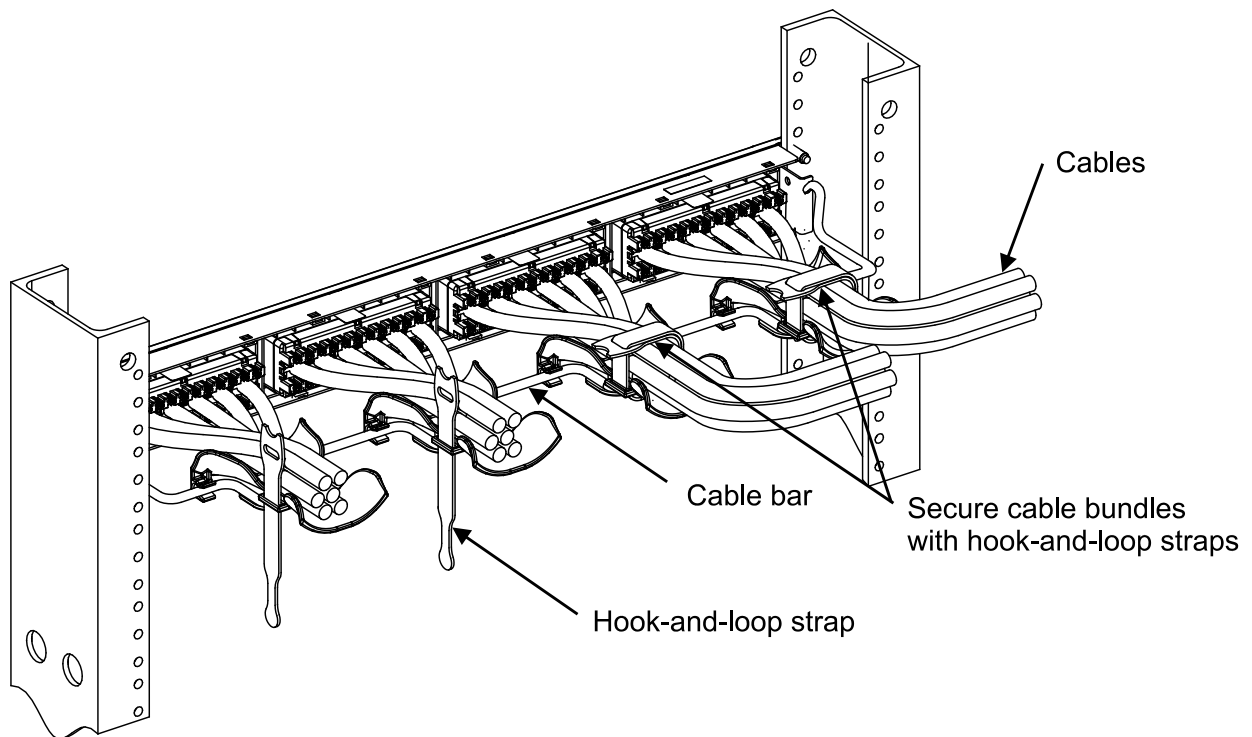

2. Attach cable bar to rear of panel. For 48-port panels, two cable bars are provided.
3. Lay cables evenly in cable troughs and secure using hook-and-loop straps as shown.

Step 5 – Install Front Labels and Label Covers

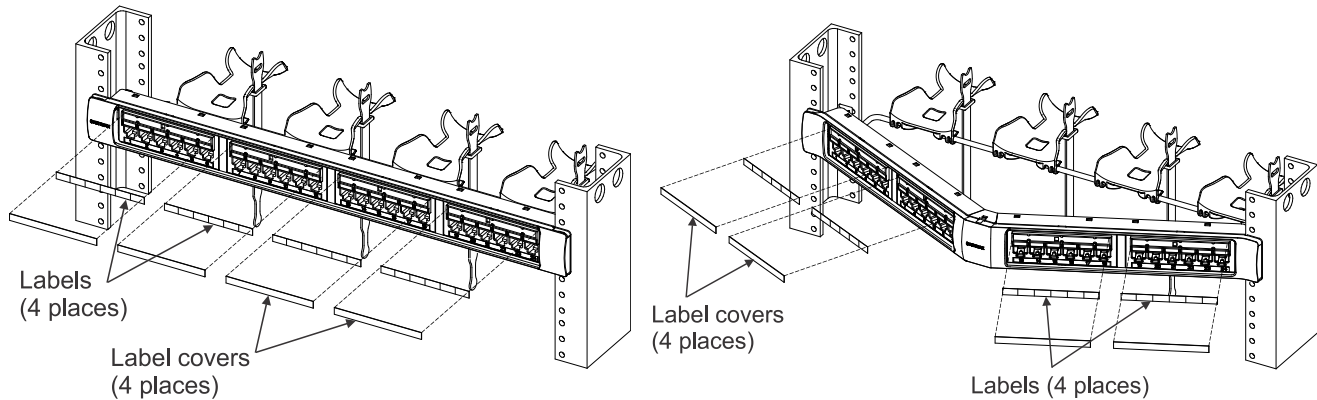

1. Print the port designations on the white label cards provided. Slide labels and label covers into the label holders from either end. Each label holder will accommodate labels up to .265 inches (6.7mm) high x 3.50 inches (89mm) wide.
2. Blank, voice, and data icons can be ordered separately in a wide variety of colors and placed into the pockets in the lower portion of the label holders.

Note: Product code M61K-XX (blank, voice, and data icons) to be ordered separately. XX denotes the color abbreviation.

3. To print a designation label, go to <http://www.commscope.com/Resources/Labeling-Templates> and scroll down to **360 Panels and Shelves**. Select the proper label template:
 - **360 Evolve-360 PATCHMAX UNP Label Sheet A4 (760186502)**
 - OR
 - **360 Evolve 360 PATCHMAX UNP Label Sheet US LTR (760183244)**.

Note: Labeling website has two options for printing labels; letter size and A4 size.

Instructions for Installing Fiber Components in Panel

Step 2a – Install Evolve Fiber Adapter Bezels

Note: Fiber modules, bezels, rear trunk cable management bar, and front fiber management trough are ordered separately.

1. Position a bezel against opening from rear of panel. Push bezel from the rear until it snaps into panel opening. Repeat for all bezels.

Step 3a – Install Evolve G2 Fiber Trunk Cable Management Bar on Rear of Panel

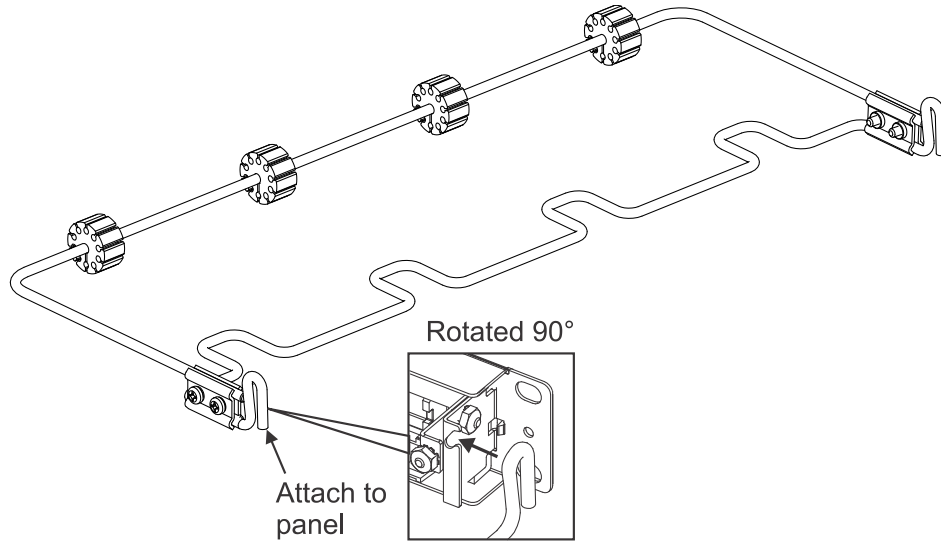

1. Attach fiber management bar to rear of panel immediately behind the fiber row. Place hook at both ends of bar into slots in panel brackets as shown.

Step 4a – Install Evolve G2 Fiber Management Trough on Front of Panel

Note: For instructions on installing the fiber management trough, see 860548809 **SYSTIMAX 360 1100 Evolve G2 Fiber Management Trough**.

1. Refer to the instructions packaged with the trough and install either the 1U trough on front of the 24-port panel or the 2U trough on front of the 48-port panel.
2. Refer to the instructions packaged with the trough and install designation labels on trough door.

Step 5a – Populate Panel with Fiber Modules

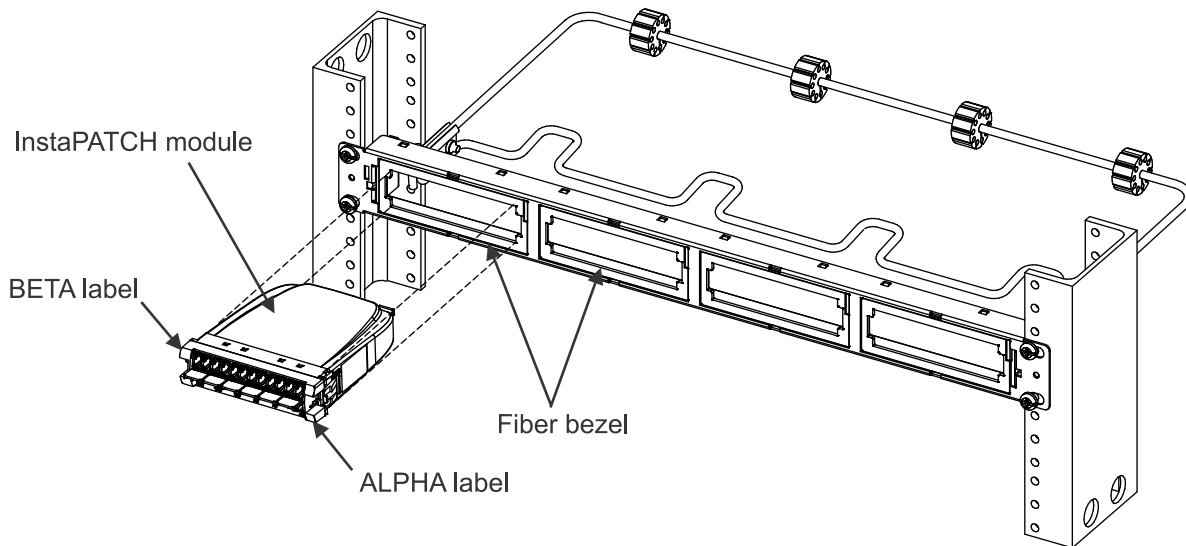

1. Orient module in ALPHA or BETA position as required and insert into one of the openings in the panel.
2. Push module into opening until latches engage with an audible click.
3. Repeat for remaining modules.

Step 6a – Install and Route Fiber Trunk Cables

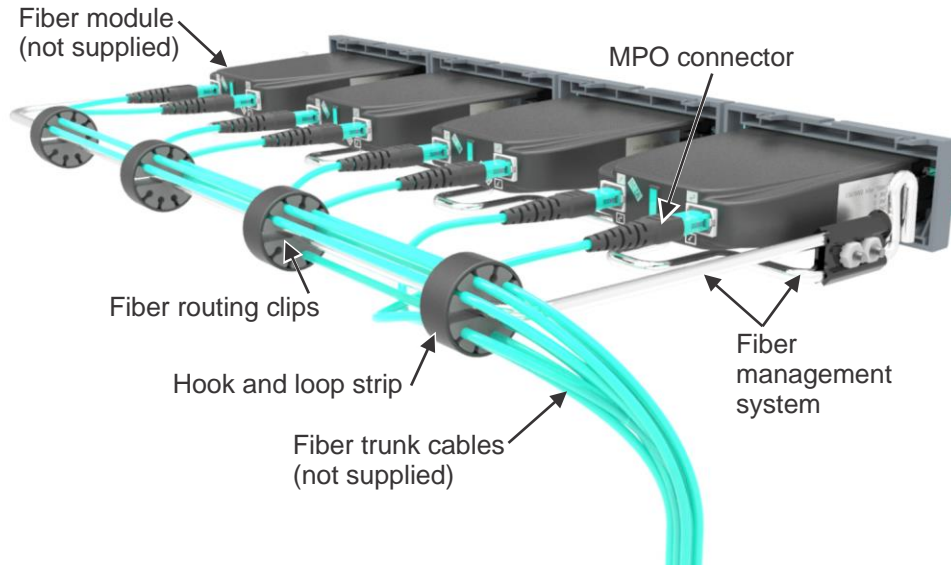

1. Terminate MPO connectors into modules.
2. Slip fiber routing clips over fiber management bar at equally spaced positions, similar to as shown above.
3. Spread open a slot position provided on fiber routing clip and secure fiber cable inside.
4. Repeat until all cables are inserted in the clips and adjust position of clips as necessary to hold the trunk cables in an organized manner.
5. Wrap a strip of hook-and-loop fastener around each fiber routing clip to secure cables.

(Optional Step) Removing Covers from Panel

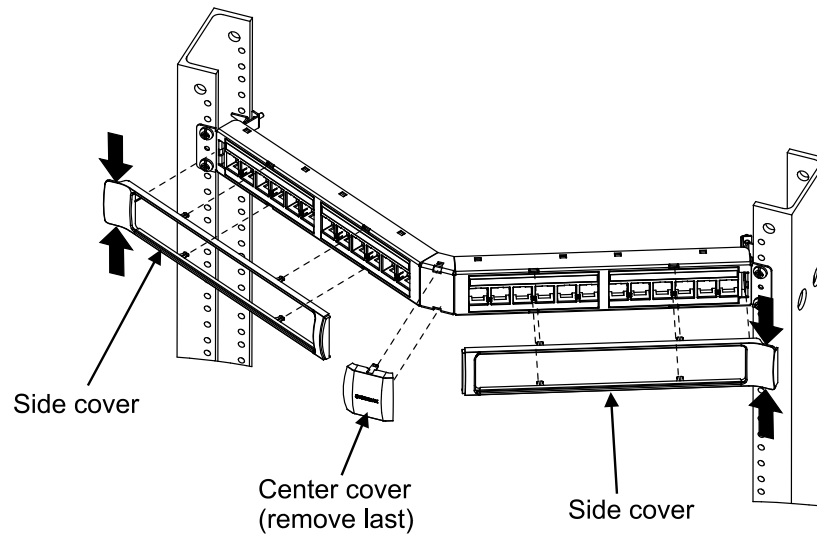

1. When removing either the flat or angled panel side cover(s), grip cover on the top and bottom at the outside edge where shown by arrows and pull forward. As cover tabs release, position fingers close to tabs to apply further pulling force.
2. For angled panel only, remove both side covers from panel before removing center cover.

Patch Panel Termination Manager Instructions

The termination managers provide pair positioning, control, and strain relief features to the rear termination area of the panel. See Figure 1. Instructions for using the termination manager are listed below.

Feed Pairs into Termination Manager (Figure 2)

1. Trim jacket back at least 3 inches (76mm) to expose twisted pairs.
2. Without crossing over or rearranging pairs out of the jacket, position pairs in-line per pair colors below:

T568B Wiring Application (Shown)

Blue, Brown, Orange, Green

T568A Wiring Application

Blue, Brown, Green, Orange

3. Insert pairs through 4 holes on top surface of termination manager, one pair per hole, as shown.
4. Continue to feed pairs through termination manager until resistance is encountered at the jacket. This will usually be about 1/4 inch (6mm) from the jacket.

Fold Pairs into Slots (Figure 3)

5. Fold each pair over into adjoining slots on bottom end of termination manager. Conductor colors must be arranged in the slots as listed below:

T568B Wiring Application (Shown)

BL/OR Pairs – Blue/Orange conductors on top

BR/GR Pairs – both White conductors on top

T568A Wiring Application

BL/GR Pairs – Blue/Green conductors on top

BR/OR Pairs – both White conductors on top

Important: Add twist as needed to align pairs with slots. Never remove twist for any pair. Do not allow pairs to untwist inside termination manager or inside cable jacket.

6. Ensure that both conductors of each pair are in slots completely without being pinched over bottom end surface.

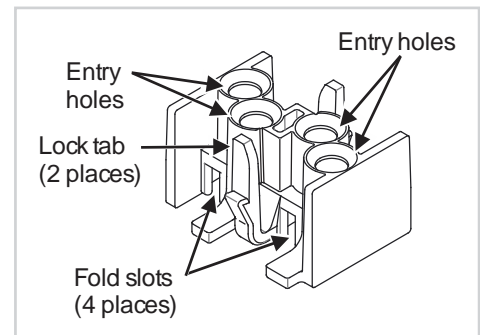

Figure 1. Termination Manager

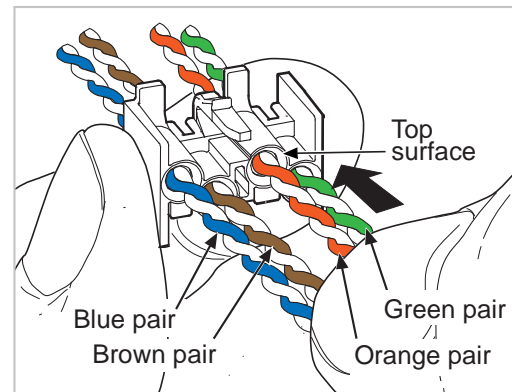

Figure 2. Feed Pairs into Termination Manager

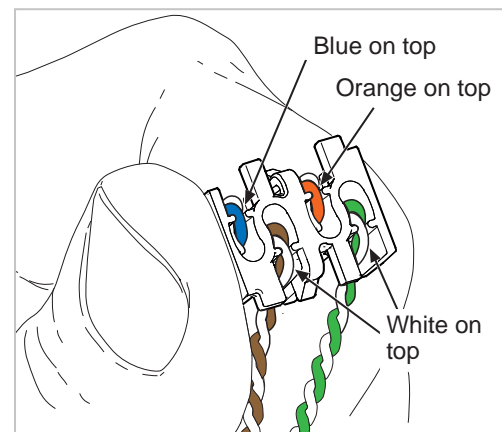

Figure 3. Fold Pairs Back into Slots

Snap Termination Manager onto Rear Housing (Figure 4)

7. Snap assembled termination manager onto rear housing with pair colors in proper position. Push on using the termination manager housing, not by pushing with the cable. (Ensure that both lock tabs on manager fully seat into rear housing).
8. After termination manager is snapped onto rear housing, untwist individual pairs fully and line up correct color conductor and white conductor with the label on the rear housing.

Seat Wires into IDC Terminal Slots (Figure 5)

9. Grasping each untwisted pair, push the conductors down into IDC terminal slots to seat them before punching down. Seat down into slots as far as possible. (It may be easier to use needle nose pliers to perform this task).
10. Using the D-914 punch tool with M110 blade on HI impact setting, punch down conductors making sure the tool is straight and that conductors fully engage in the IDC terminals. Stagger the punch-down tool up and down, so that it stays in alignment with the staggered terminal slots.

Recommendations to Aid Assembly

1. The termination manager should be snapped onto the rear housing immediately after the pairs have been fed and folded over into the slots. All termination managers should be installed on the panel before proceeding to seat and punch down conductors.
2. Flex cables down for easier access, then seat and punch down the entire top row of the panel.
3. Flex cables up for easier access, then seat and punch down the entire bottom row.

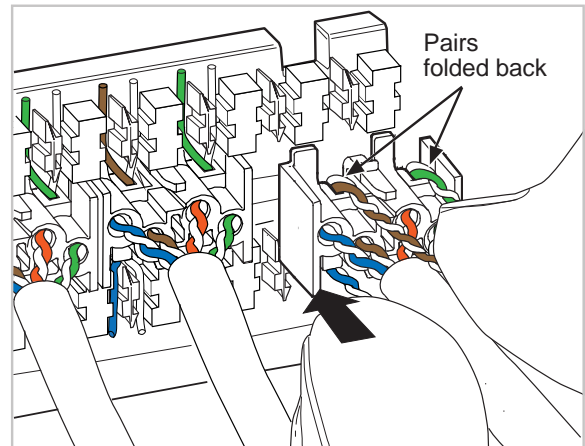

Figure 4. Snap Termination Manager onto Rear Housing

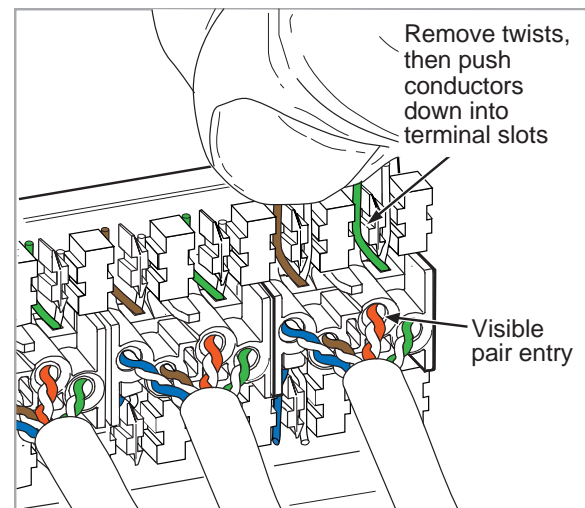

Figure 5. Seat Untwisted Pairs into IDC Terminal Slots