

REVISIONS			
REV	DESCRIPTION	DATE	APPROVED
C	20262032	31-MAR-09	JSL
D	40087785CMO	25-APR-2019	MAM

PARTS LIST	
PART	QTY
INSERTABLE DOWNSPOUT	1
CONNECTING BARS	8
1/4-20 SCREWS	8
1/4-20 NUTS	16
1/4 WASHERS	8
SQUARE RETAINING WASHER	8
LABELS	2

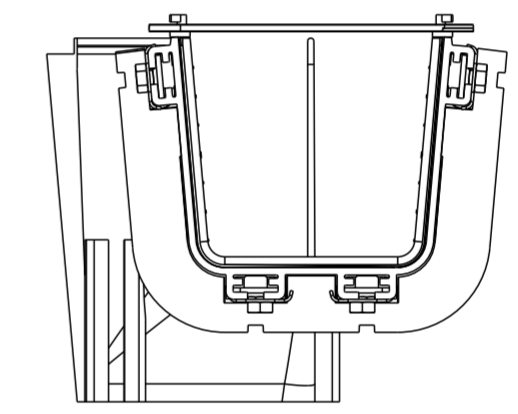
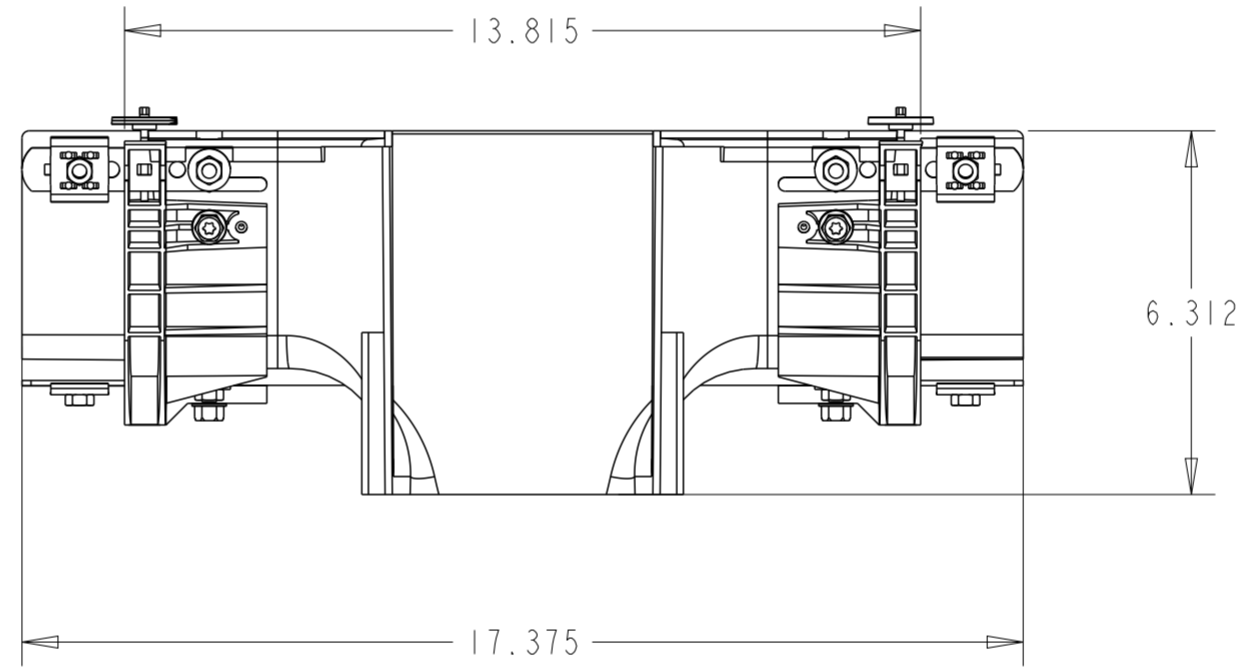
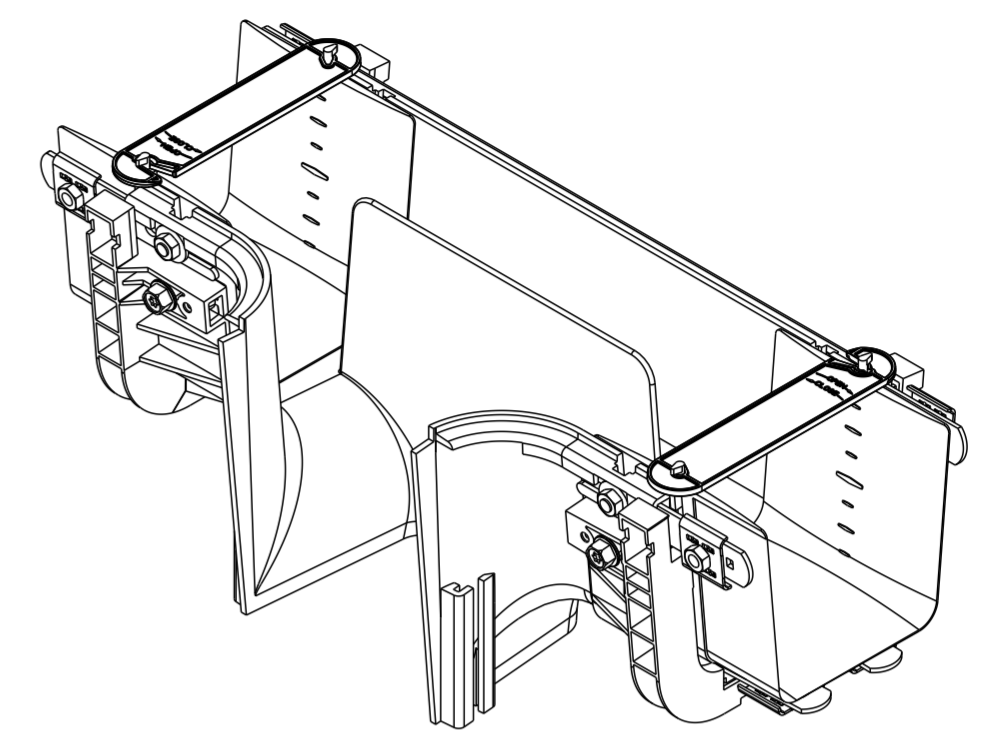

ASSEMBLY INSTRUCTIONS:

- 1) CUT A 14.0 ± 0.1 INCH SECTION OUT OF THE FIBERGUIDE SPAN WHERE THE DOWNSPOUT WILL BE INSERTED AS SHOWN IN FIGURE 1.
- 2) INSERT (8) 1/4-20 SCREWS INTO THE (8) CONNECTING BARS. SLIDE THE (8) CONNECTING BARS INTO THE SLOTS ON THE SIDE OF THE FIBERGUIDE SPAN. THE "FORKED" END OF THE BARS SHOULD FACE THE OPENING AS SHOWN IN FIGURE 1.
- 3) INSERT THE DOWNSPOUT INTO THE CUTOUT SECTION AS SHOWN IN FIGURE 1.
- 4) SLIDE THE CONNECTING BARS AROUND THE SCREWS PRE-ASSEMBLED INTO THE DOWNSPOUT. FASTEN WITH (8) WASHERS AND (8) 1/4-20 NUTS AS SHOWN IN FIGURE 2.
- 5) ATTACH (8) SQUARE RETAINING WASHERS AND (8) NUTS ONTO THE SCREWS IN THE FIBERGUIDE SPAN AS SHOWN IN FIGURE 2.

FGSB-MDSP-B/I	BLACK	6"
FGSB-MDSP-A/I	BLACK	4"
FGS-MDSP-B/I	YELLOW	6"
FGS-MDSP-A/I	YELLOW	4"
ADC CATALOG NUMBER	COLOR	SIZE

COMMSCOPE, INC.												
TOLERANCES					SAP MATERIAL MASTER							
N/A												
FINISH					MATERIAL							
SEE NOTES					SEE BOM							
UNLESS OTHERWISE SPECIFIED DIMENSIONS ARE IN MILLIMETERS	DRAFTER			TITLE								
	MIGUEL MUÑOZ			INSERTABLE DOWNSPOUT INSTALLATION DRAWING								
	CHECKER			SIZE			SCALE			DOCUMENT NO.		
	OSCAR VALENZUELA			A2			0.200			1025797_ADC		
ENGINEER			CMO									
RUBEN ARVILLA			40087785CMO									
ALL SURFACES			WORK AREA: 58			MODEL			DRAWING			SHEET
✓						VERSION			STATUS			REVISION
						01			01			RE D
												1 OF 2

© 2019 CommScope, Inc. Confidential
 NOTICE: These drawings and specifications are the proprietary property of COMMSCOPE, INC. and may be used only for the specific purpose authorized in writing by COMMSCOPE, INC.

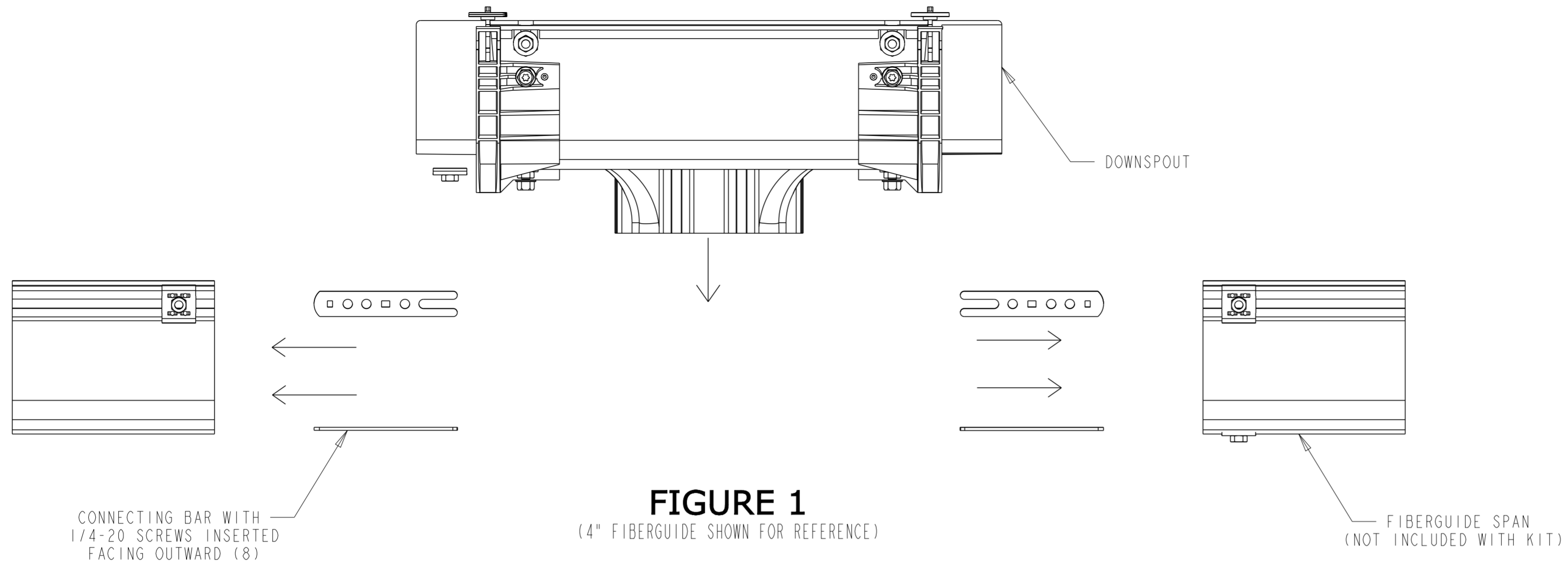

FIGURE 1
(4" FIBERGUIDE SHOWN FOR REFERENCE)

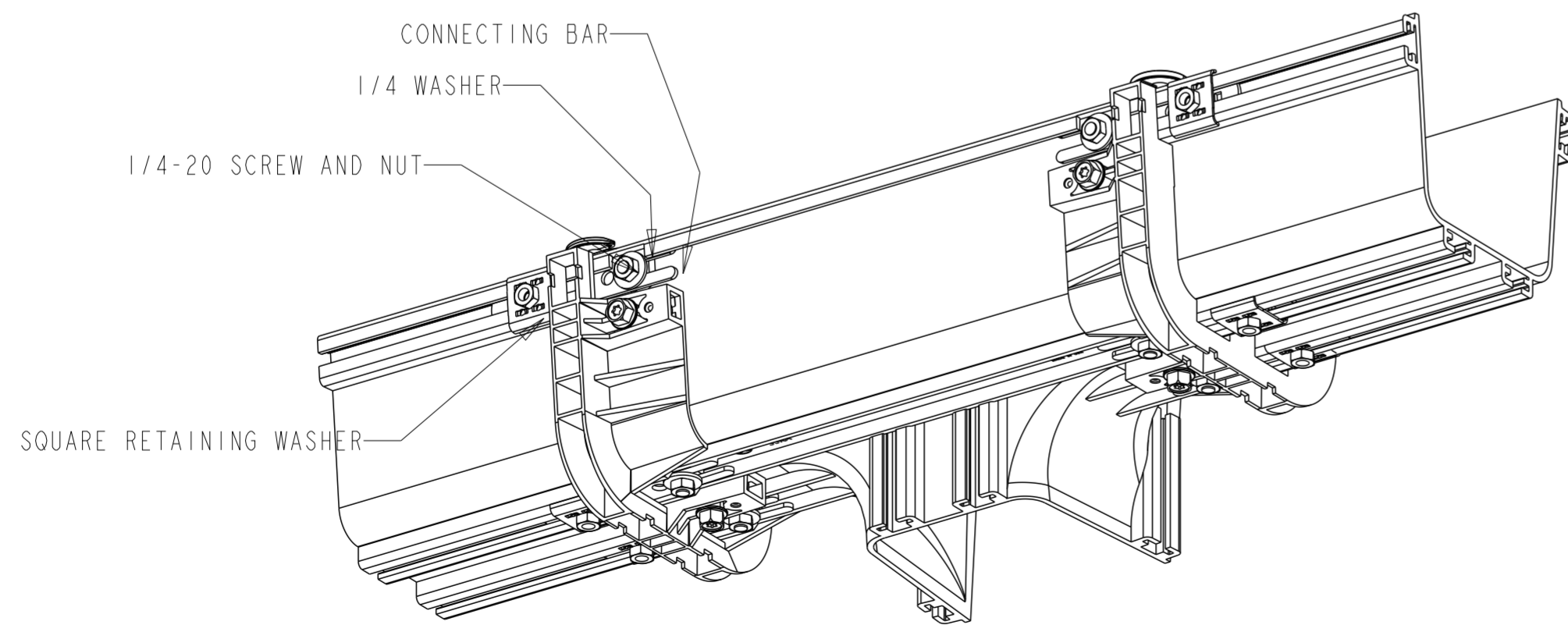

FIGURE 2
(4" FIBERGUIDE SHOWN FOR REFERENCE)

© 2019 CommScope, Inc. Confidential
NOTICE: These drawings and specifications are the proprietary property of COMMScope, INC. and may be used only for the specific purpose authorized in writing by COMMScope, INC.

COMMScope, INC.				
TITLE INSERTABLE DOWNSPOUT INSTALLATION DRAWING				
SIZE A 2	SCALE 0.200	DOCUMENT NO. 1025797_ADC		
DRAWING			SHEET	
VERSION 01	STATUS RE	REVISION D	2 OF 2	

