

REV.	MCO	DWN	DATE
I	40028044MCO	TH	07-APR-16
B	40032778MCO	OAVL	10-AUG-16

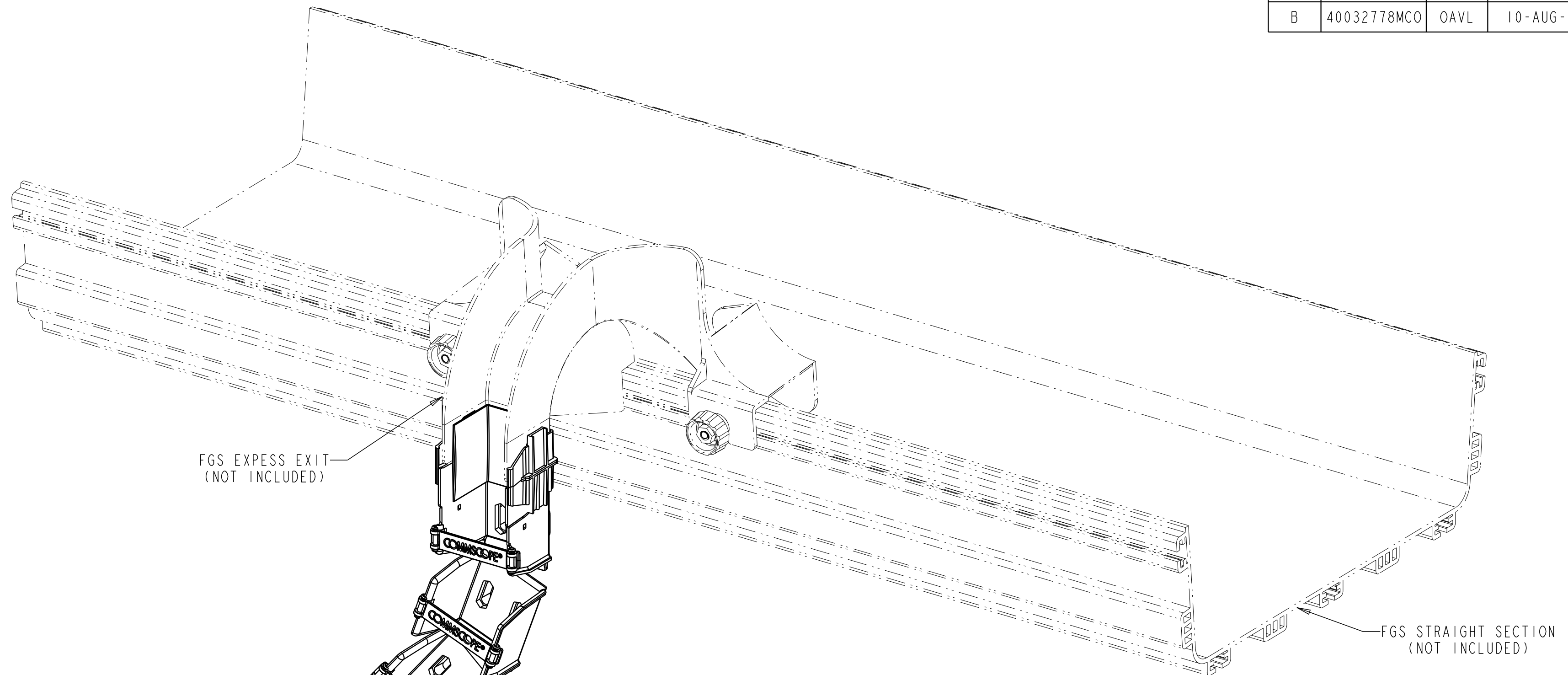

FGS EXPRESS EXIT
(NOT INCLUDED)

FGS STRAIGHT SECTION
(NOT INCLUDED)

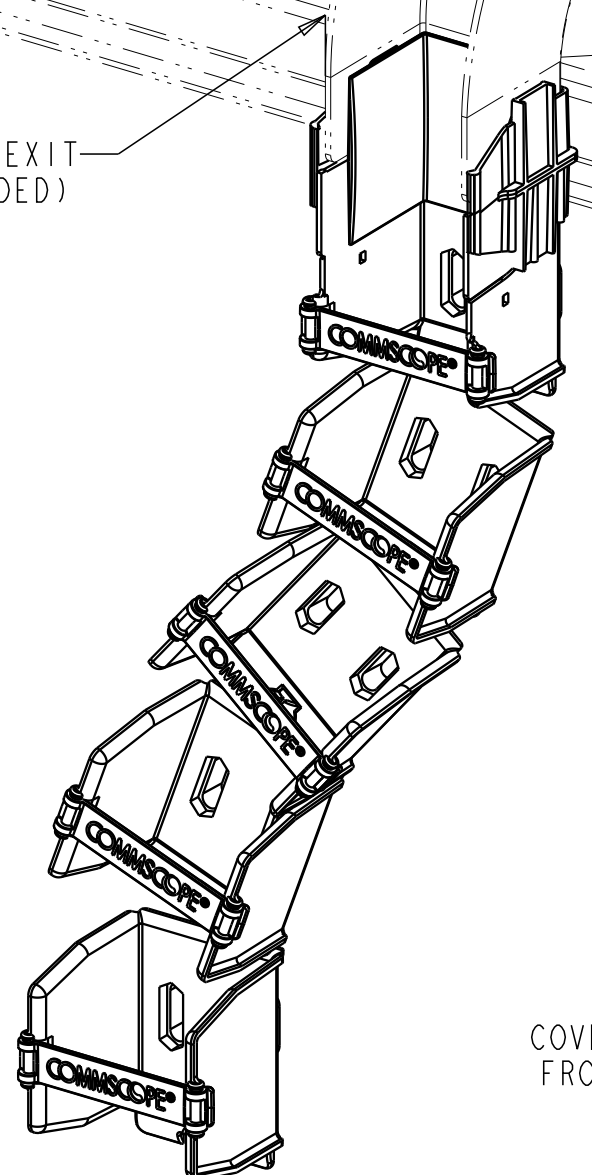

COVER STRAP OPENS
FROM EITHER SIDE

002

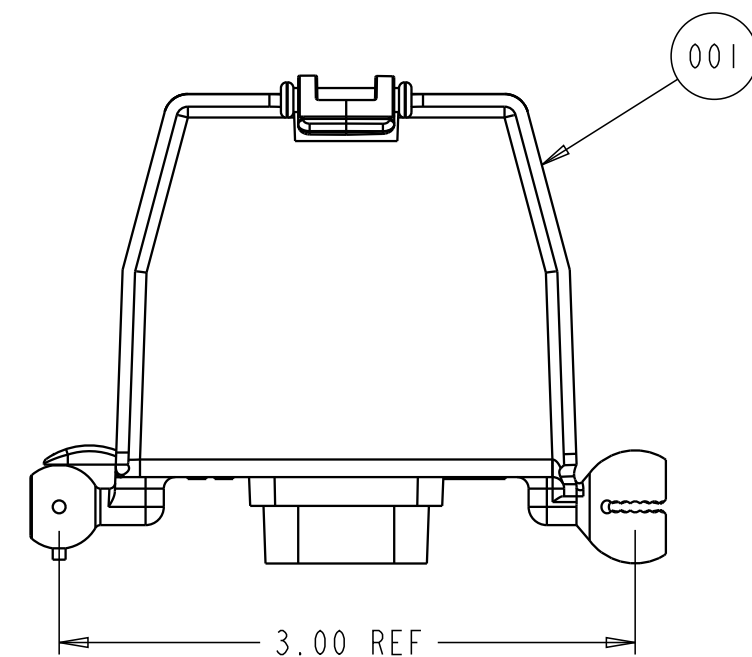
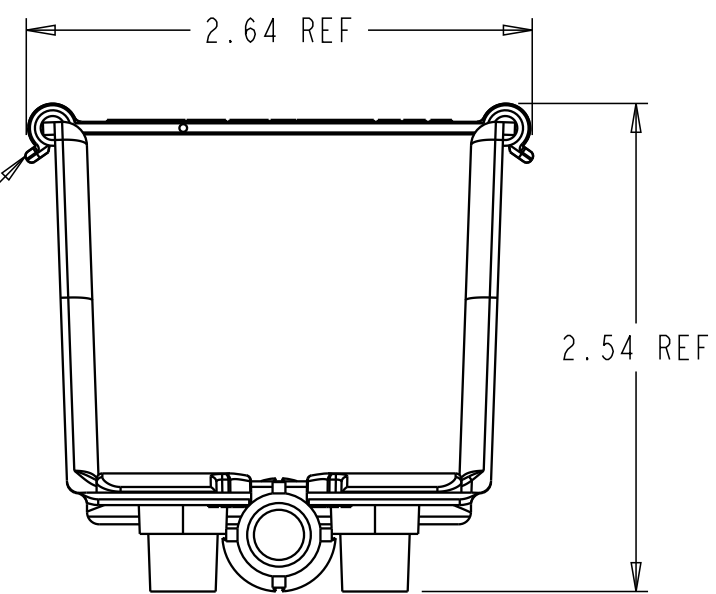

2X2 TROUGH DIMENSIONS

KIT CONTAINS		
ITEM	DESCRIPTION	QUANTITY
001	TROUGH, 2X2	16 (4 FT)
002	STRAP, TROUGH	20
003	TROUGH, UNIV, 2X2	2
004	JUNCTION, 2X2	2
100	SCREW, PAN HEAD, #12-24 X .75	4
101	SCREW, HEX HEAD, #12-24 X .75	4
102	WASHER, FLAT, #12	4
103	NUT, #12-24	4

CATALOG NO.: FGS-FLEXV-4F-C

COMMSCOPE, INC.

<small>© 2016 COMMSCOPE, INC. CONFIDENTIAL NOTICE: THESE DRAWINGS AND SPECIFICATIONS ARE THE PROPRIETARY PROPERTY OF COMMSCOPE, INC. AND MAY BE USED ONLY FOR THE SPECIFIC PURPOSE AUTHORIZED IN WRITING BY COMMSCOPE, INC.</small>		TITLE INSTL, KIT, 4FT, 2X2, FLEXV	
<small>ALL DIMS AND TOLERANCES ARE INCHES UNLESS OTHERWISE SPECIFIED</small>	<small>.XX:±N/A .XXX:±N/A ANGULAR:±N/A</small>	C SIZE DRAWING NUMBER 300100115178	B REV
DO NOT SCALE DRAWING		ENGR: JIM SOLHEID DWN: TIM HAATAJA	SHT. 1 OF 3

DIMENSIONS IN INCHES
 THIRD ANGLE PROJECTION

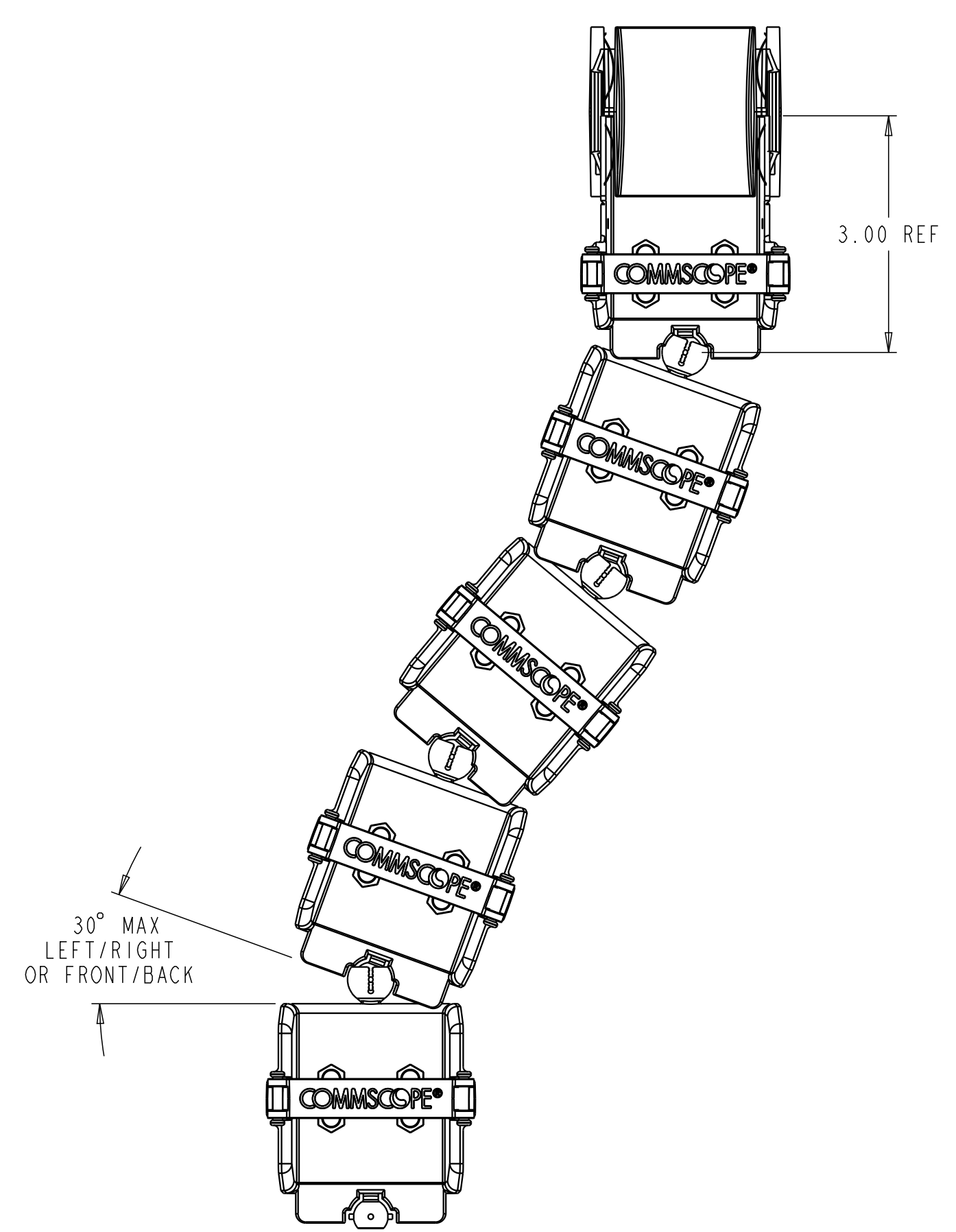
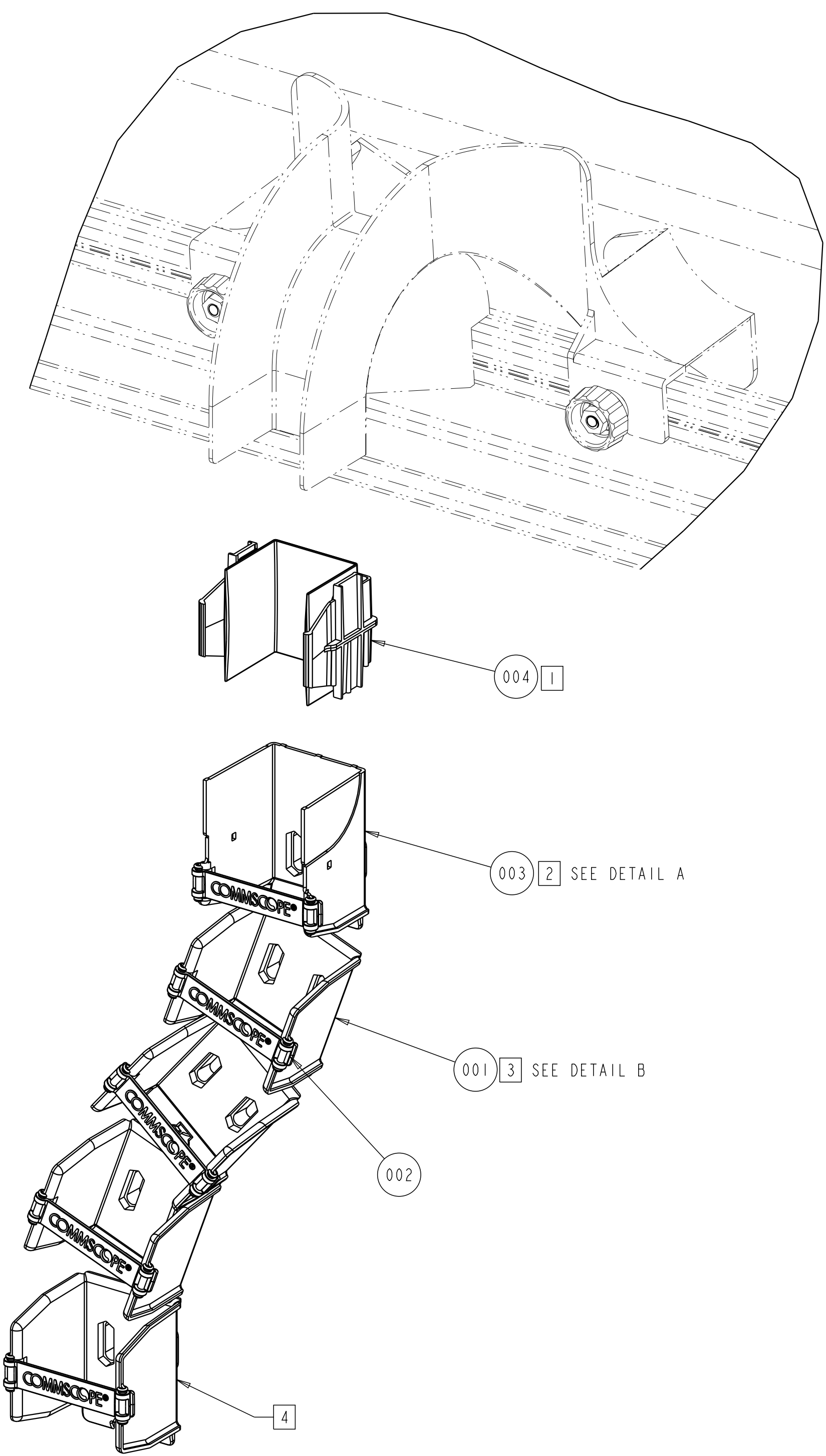

INSTALLATION INSTRUCTIONS:

- 1 ASSEMBLE ITEM 004 (2X2 JUNCTION) TO EXISTING 2X2 FITTING.
- 2 ASSEMBLE BALL HALF OF ITEM 003 (2X2 UNIV TROUGH) TO ITEM 004. SEE DETAIL A, SHEET 3.
- 3 ASSEMBLE SECTIONS OF ITEM 001 (2X2 TROUGH) TO ACHIEVE REQUIRED LENGTH. SEE DETAIL B, SHEET 3.
- 4 SELECT TROUGH END PIECE REQUIRED AND ATTACH TO TROUGH ASSEMBLY. SEE DETAIL C, SHEET 3.
5. ATTACH TROUGH END PIECE TO FRAME OR BRACKET USING HARDWARE PROVIDED, SEE DETAIL D, SHEET 3.

COMMSCOPE, INC.

<small>© 2016 COMMSCOPE, INC. CONFIDENTIAL NOTICE: THESE DRAWINGS AND SPECIFICATIONS ARE THE PROPRIETARY PROPERTY OF COMMSCOPE, INC. AND MAY BE USED ONLY FOR THE SPECIFIC PURPOSE AUTHORIZED IN WRITING BY COMMSCOPE, INC.</small>		TITLE INSTL, KIT, 4FT, 2X2, FLEXV	
<small>ALL DIMS AND TOLERANCES ARE INCHES UNLESS OTHERWISE SPECIFIED</small>	<small>.XX:±N/A .XXX:±N/A ANGULAR:±N/A</small>	C SIZE	DRAWING NUMBER 300100115178
DO NOT SCALE DRAWING		ENGR: JIM SOLHEID DWN: TIM HAATAJA	SHT. 2 OF 3

DIMENSIONS IN INCHES
 THIRD ANGLE PROJECTION

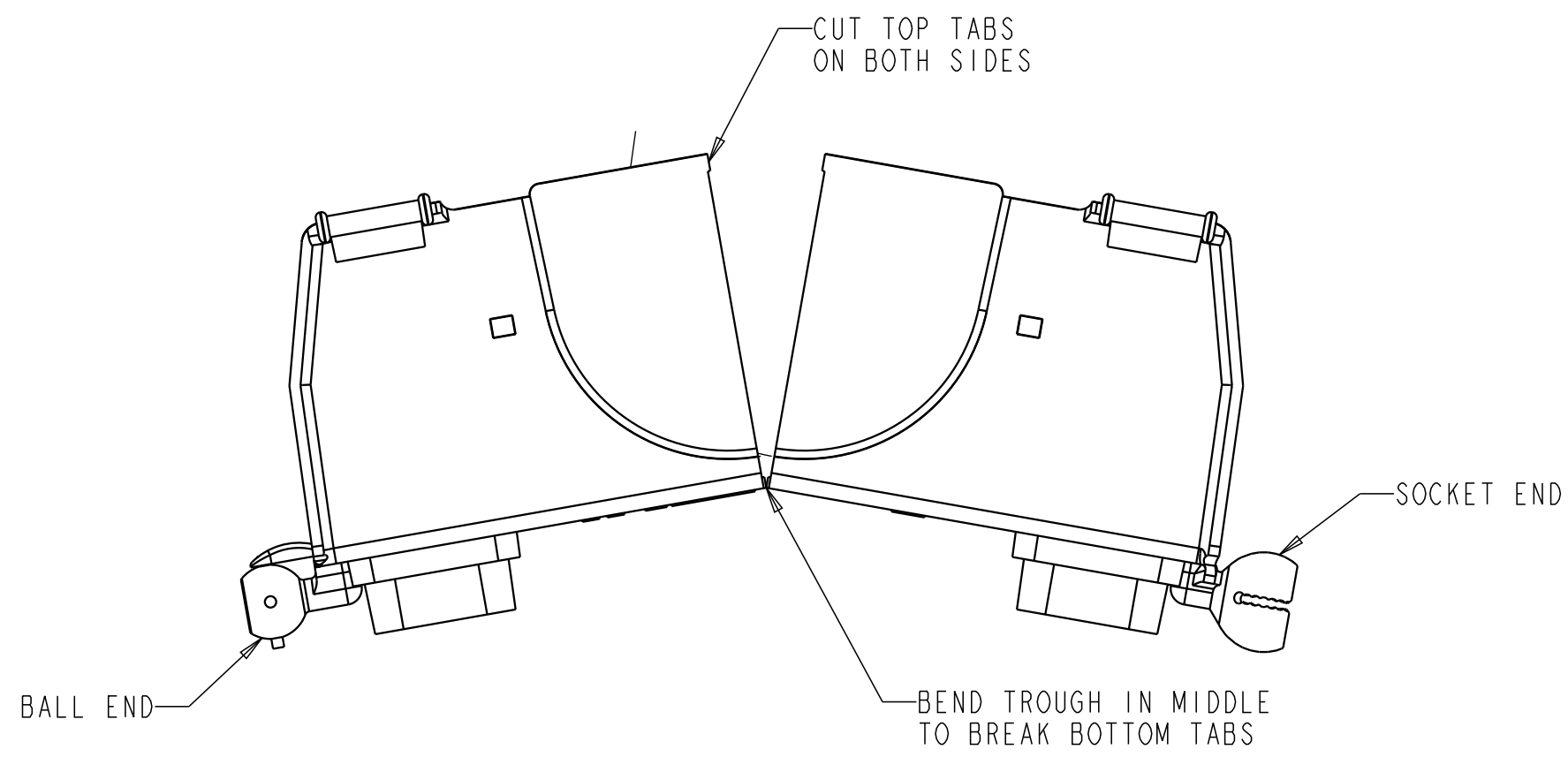

DETAIL A
UNIVERSAL TROUGH SPLIT

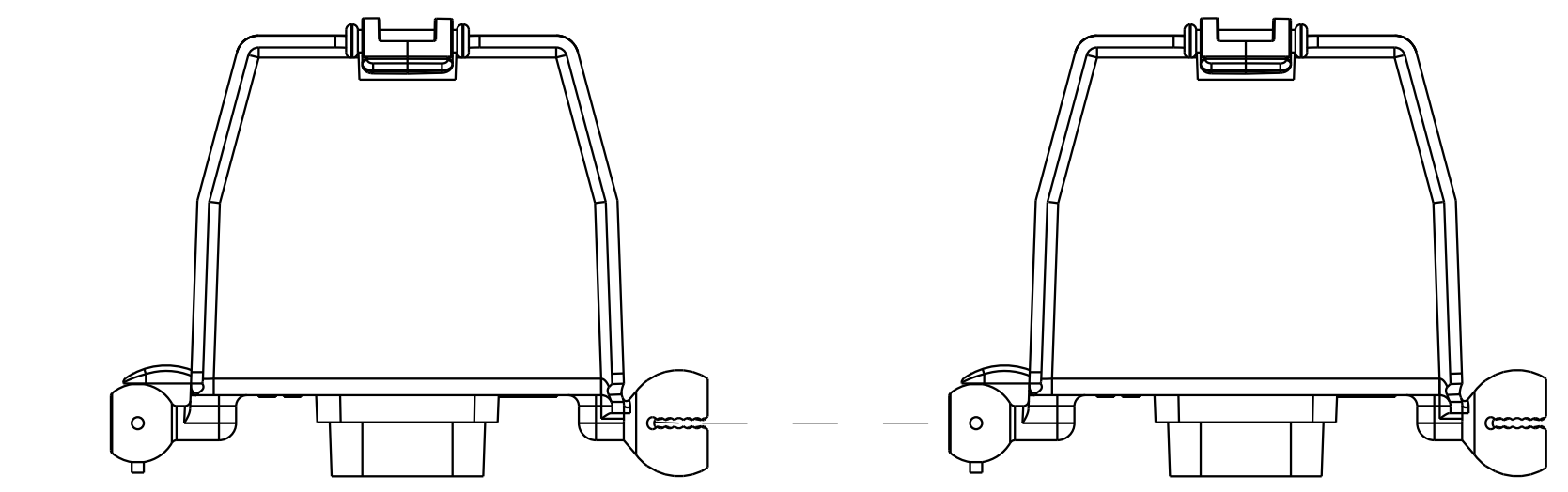

ALIGN BALL AND SOCKET
ON TROUGH PIECES

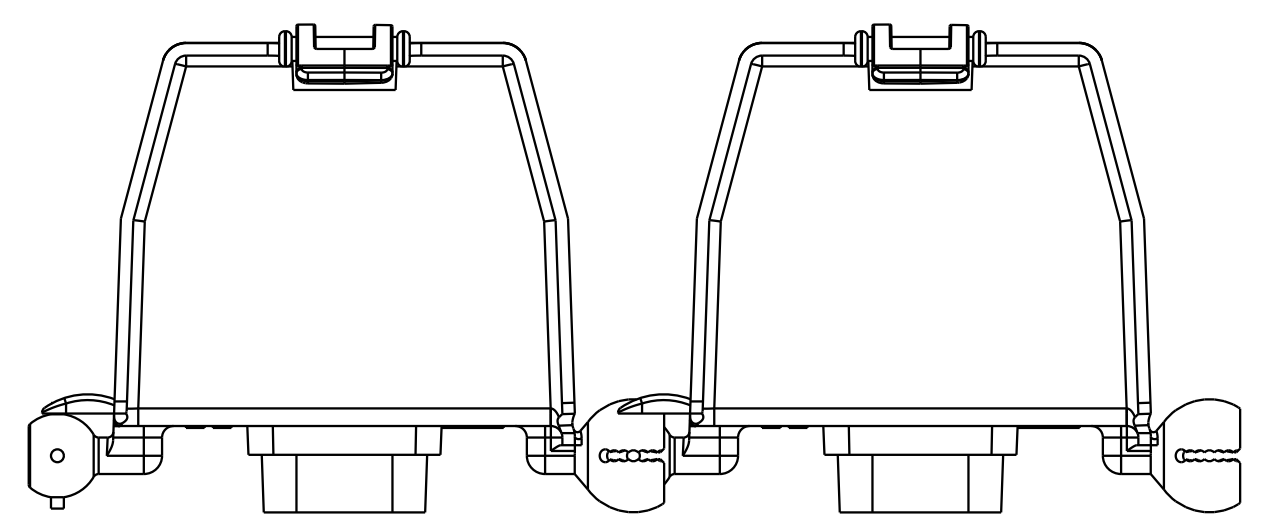

INSERT BALL INTO SOCKET
UNTIL FULLY SEATED

DETAIL B
TROUGH ASSEMBLY

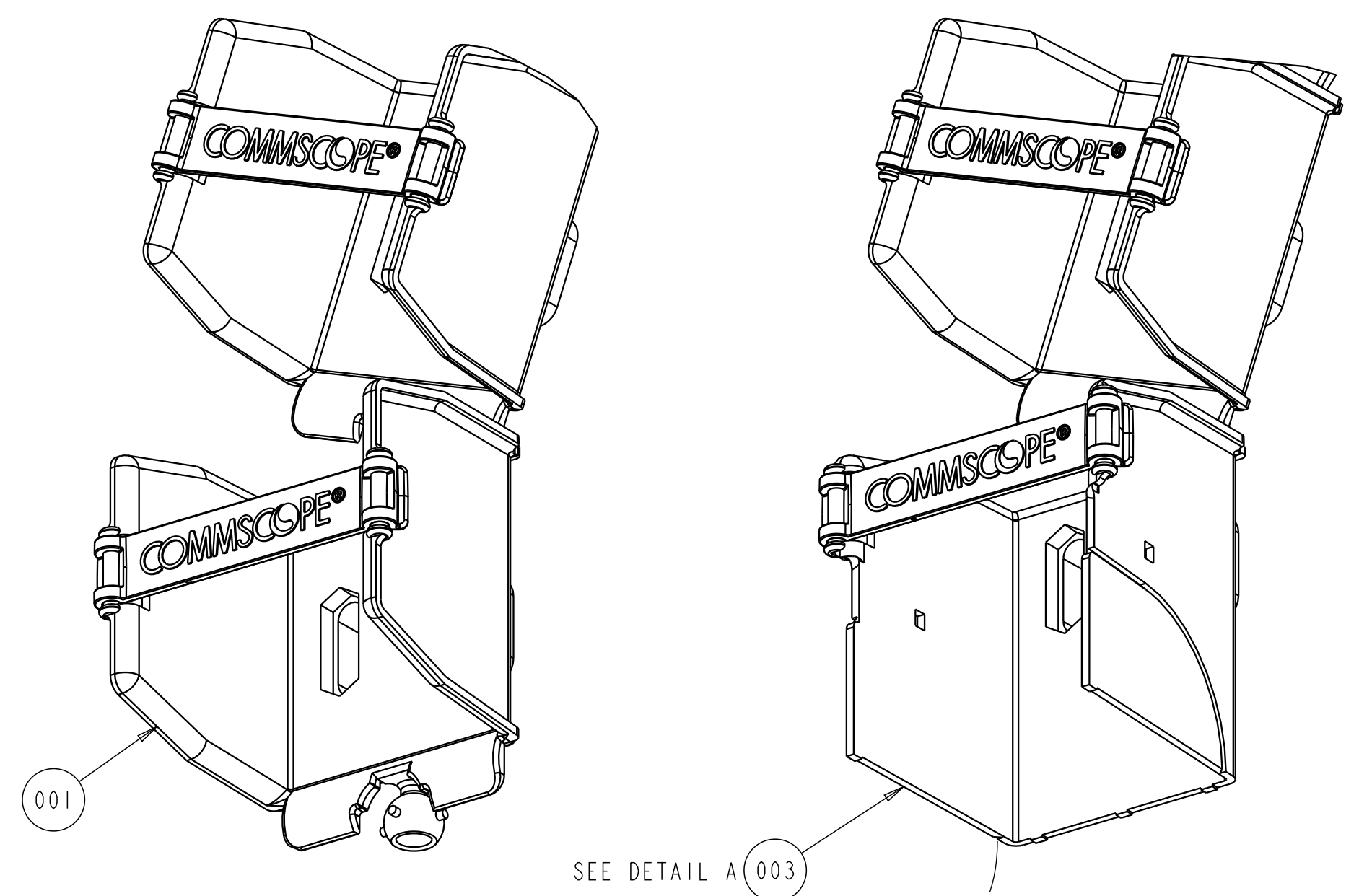

OPTION 1
2X2 TROUGH
(USED IF CONNECTING TO
FLEX VERTICAL TROUGH KIT)

OPTION 2
2X2 UNIVERSAL TROUGH - SOCKET END
(USED IF CONNECTING TO 2X2 SOLID
OR 2X2 SLOTTED VERTICAL DUCT,
FOR USE WITH 2X2 JUNCTION)

DETAIL C
TROUGH END OPTIONS

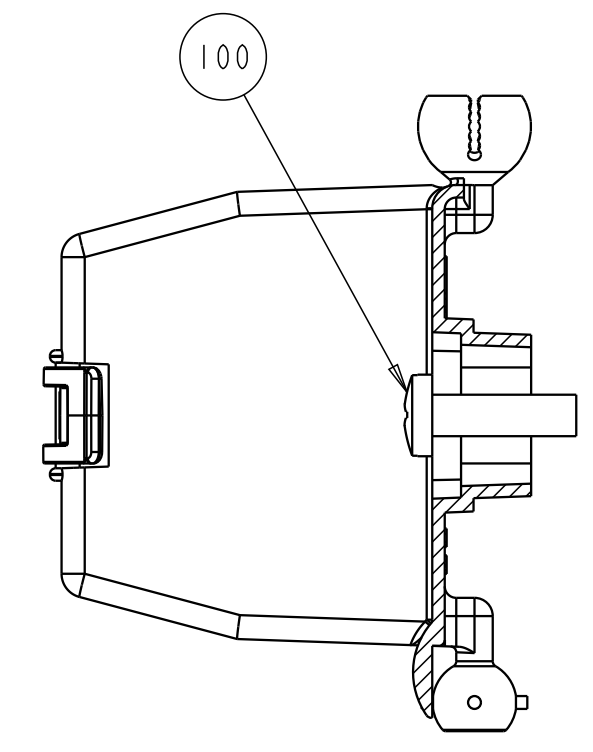

OPTION 1
(IF ATTACHING TO BRACKET
WITH #12-24 THREADED HOLE)

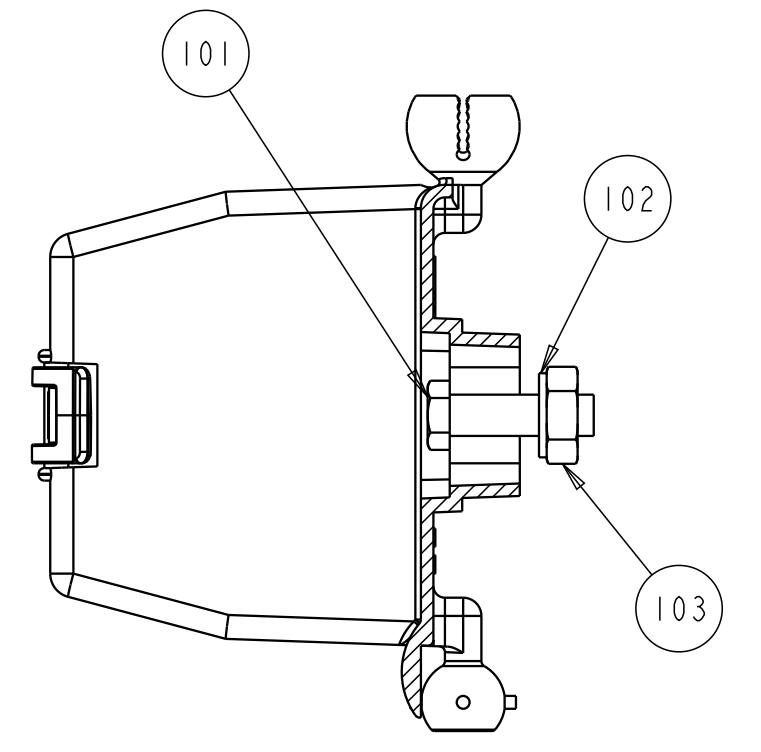

OPTION 2
(IF ATTACHING TO BRACKET
WITH CLEARANCE HOLE)

DETAIL D
HARDWARE INSTALLATION

COMMSCOPE, INC.

© 2016 COMMSCOPE, INC. CONFIDENTIAL
NOTICE: THESE DRAWINGS AND SPECIFICATIONS
ARE THE PROPRIETARY PROPERTY OF
COMMSCOPE, INC. AND MAY BE USED ONLY FOR THE
SPECIFIC PURPOSE AUTHORIZED IN WRITING BY
COMMSCOPE, INC.

TITLE
INSTL, KIT,
4FT, 2X2, FLEXV

ALL DIMS AND TOLERANCES .XX:±N/A
ARE INCHES UNLESS .XXX:±N/A
OTHERWISE SPECIFIED ANGULAR:±N/A

C
SIZE
DRAWING NUMBER
300100115178
B
REV

DO NOT SCALE DRAWING

ENGR: JIM SOLHEID
DWN: TIM HAATAJA

SHT. 3 OF 3

DIMENSIONS IN INCHES
THIRD ANGLE PROJECTION