

THIS DRAWING IS UNPUBLISHED. RELEASED FOR PUBLICATION
 © 2016 COMMScope, INC. CONFIDENTIAL NOTICE: THESE DRAWINGS AND SPECIFICATIONS ARE THE PROPRIETARY PROPERTY OF COMMScope, INC. AND MAY BE USED ONLY FOR THE SPECIFIC PURPOSE AUTHORIZED IN WRITING BY COMMScope, INC.

REVISIONS					
P	LTR	DESCRIPTION	DATE	DWN	APVD
C		REV; ECO-13-008563	22MAY2013	GG	TE
D		REV PER ECN 8000018129	09FEB2017	GG	TE

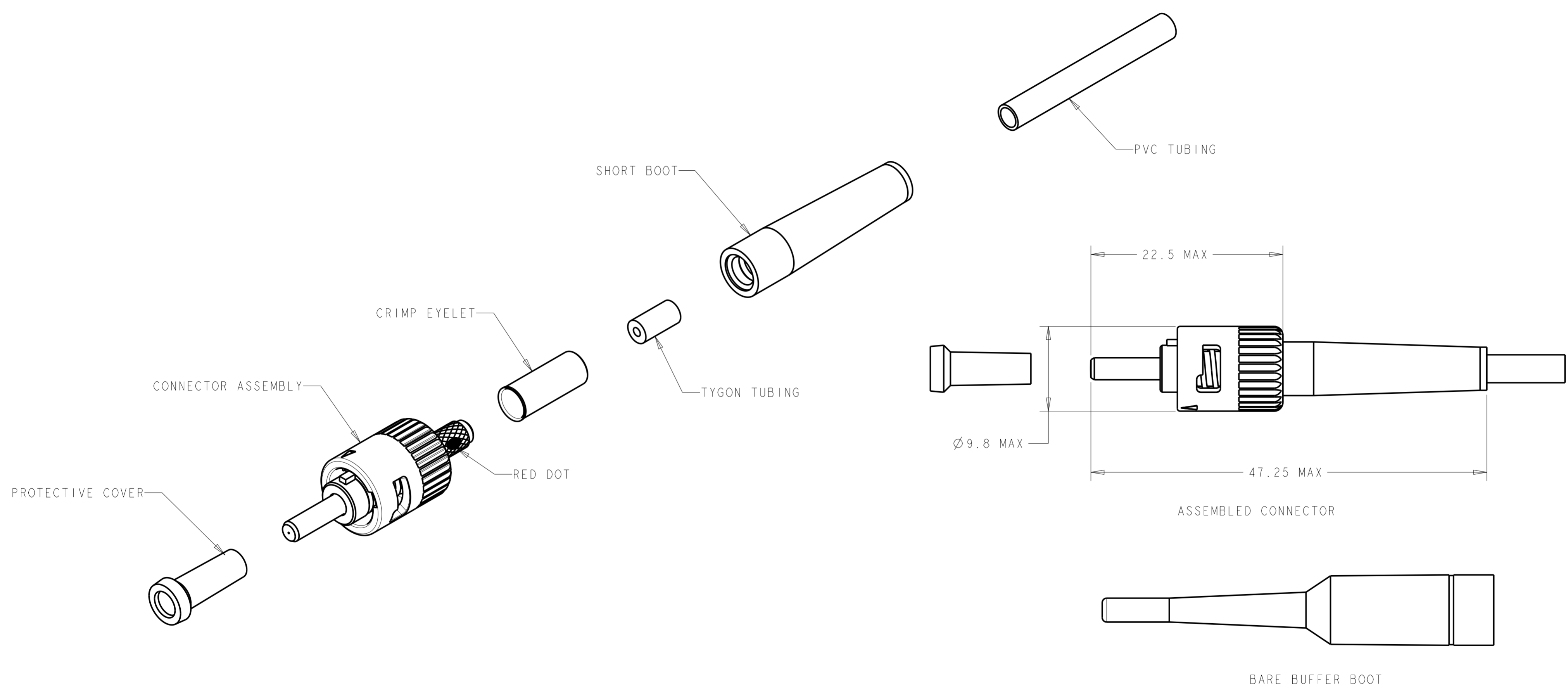

1 MATERIAL:
 PROTECTIVE COVER: LDPE, COLOR: BLACK, NON-FR.
 CONNECTOR ASSEMBLY:
 FERRULE ASSEMBLY: CERAMIC/NICKEL PLATED BRASS.
 SPRING: STAINLESS STEEL.
 COUPLING NUT: ZINC.
 RETENTION RING: STAINLESS STEEL.
 CRIMP EYELET: TIN PLATED COPPER.
 SHORT BOOT: TPE, SEE DASH NUMBERS FOR COLOR*
 TYGON TUBING: TYGON, COLOR: CLEAR.
 PVC TUBING: PVC, COLOR: BLACK, NON-FR.
 *UL94 V-0 RATED AT QUALIFYING THICKNESS.
 BUFFER BOOT: TPE, SEE DASH NUMBERS FOR COLOR.

2 BULK PACKAGE.
 3. INSTRUCTION SHEET: 408-9971

OBSOLETE	2	YELLOW	PVC	YELLOW	126 μm	5502580-8
OBSOLETE	2			BLUE	126 μm	5502580-7
OBSOLETE	2	YELLOW		YELLOW	126 μm	5502580-4
		YELLOW	PVC AND TYGON	YELLOW	126 μm	5502580-2
		BUFFER BOOT	TUBING	SHORT BOOT	FIBER SIZE	PART NUMBER

THIS DRAWING IS A CONTROLLED DOCUMENT.

DIMENSIONS: mm [INCHES]	TOLERANCES UNLESS OTHERWISE SPECIFIED: 0 PLC ± 1 PLC ± 2 PLC ± 3 PLC ± 4 PLC ± ANGLES ± FINISH	DWN B. BRIGGS 05APR2005 CHK S. BUCHTER 05APR2005 APVD S. BUCHTER 05APR2005	NAME COMMScope, INC. CONNECTOR KIT, 2.5mm BAYONET, SINGLEMODE, OPTIMATE
MATERIAL		PRODUCT SPEC APPLICATION SPEC WEIGHT	SIZE A2 CAGE CODE DRAWING NO. C-5502580 RESTRICTED TO
		Customer Drawing	SCALE 3:1 SHEET 1 OF 1 REV D