

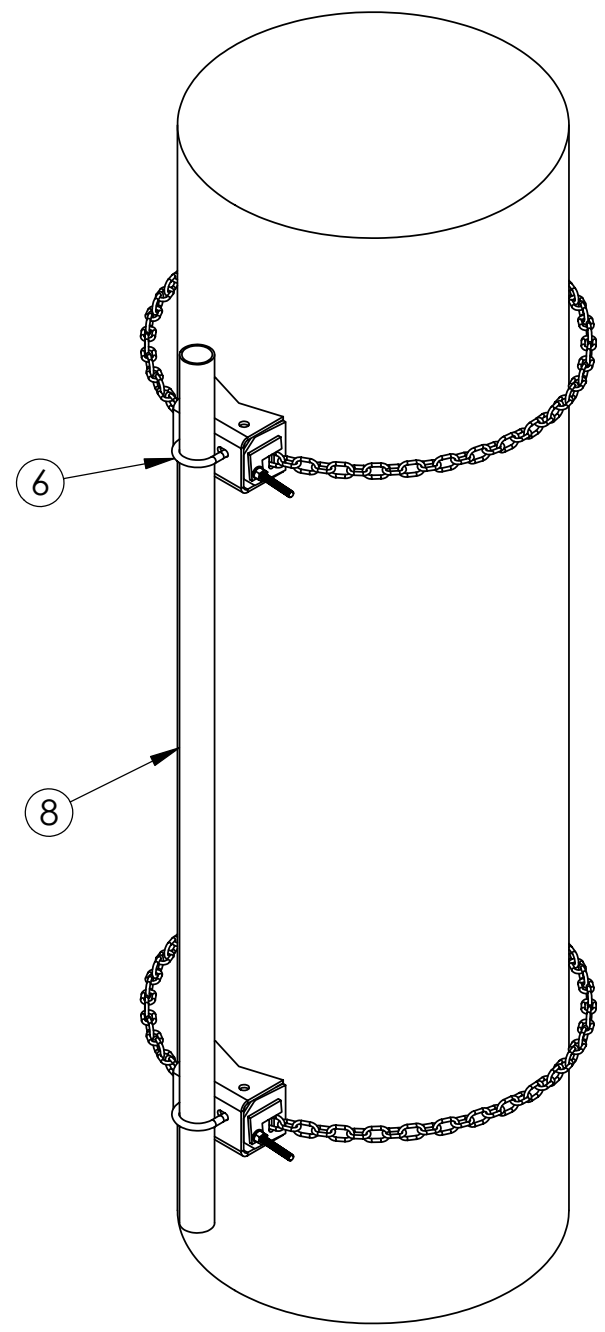

ITEM NO.	PART NO.	DESCRIPTION	QTY.	WEIGHT
1	CM.01	CHAIN MOUNT ANCHOR	2	5.95
2	CM.03	CHAIN LOCK	2	0.27
3	CM.04	1/2" RIGHT HAND THREAD JAW	2	0.55
4	GWL-04	1/2" GALV LOCK WASHER	2	0.01
5	GN-04	1/2" GALV HEX NUT (C2)	2	0.04
6	GUB-4240	1/2" X 2-1/2" X 4" GALV U-BOLT	2	0.56
7	G4-0-XXX	G-40 CHAIN (SEE TABLE)	2	
8	MT-XXX	PIPE MOUNT (SEE TABLE)		

REVISIONS				
REV.	ZONE	DESCRIPTION	BY	DATE
A		INITIAL RELEASE	AW	12/14/04

PART NUMBER	WEIGHT	PIPE MOUNT	QTY	CHAIN	CHAIN LENGTH
CM-30S-B	26.76	NONE	0	G4-0-96	8ft
CM-30S-72	47.76	MT-651	1	G4-0-96	8ft
CM-30S-96	60.26	MT-651-96	1	G4-0-96	8ft
CM-60S-B	38.76	NONE	0	G4-0-192	16ft
CM-60S-72	59.76	MT-651	1	G4-0-192	16ft
CM-60S-96	72.26	MT-651-96	1	G4-0-192	16ft

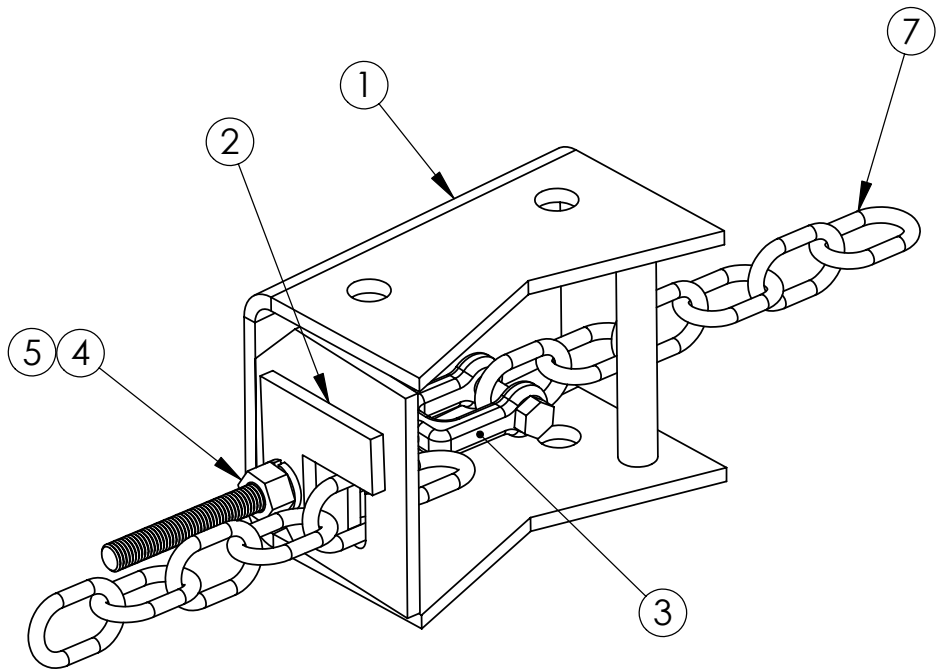

NOTES:  
 1. ATTACH THE PIPES OR PIPE MOUNTS TO THE BRACKETS PRIOR TO ADDING THE JAW- BOLT/CHAIN ASSEMBLY

<small>These drawings and specifications are the proprietary property of ANDREW CORPORATION and may be used only for the specific purpose authorized in writing by Andrew Corporation.</small> ALL DIMENSIONS ARE IN INCHES U.O.S. TOLERANCES UNLESS OTHERWISE SPECIFIED: .X = .06      ANGLES 2° .XX = .03     FRACTIONS 1/32 .XXX = .010 REMOVE BURRS AND BREAK EDGES .005 DO NOT SCALE THIS PRINT	DRAWN BY: <b>AW</b>	SHEET: 1 of 1	PART NUMBER: <b>CM-S SERIES</b>
	CHECKED BY: <b>TP</b>	SCALE: NTS	DESCRIPTION: SINGLE CHAIN MOUNT
	DATE: 12/14/04	MATERIAL: A36	DRAWING TYPE: ASSEMBLY DRAWING
	REVISION: <b>A</b>	FINISH: GALV A123	 ORLAND PARK, IL. 60462 U.S.A.