

High Speed Migration SYSTIMAX Ultra-Low-Loss configuration guide

Contents

The MPO connector, MPO pins, keys and polarity	3
- Figure 1. Pinned and unpinned MPO connectors	3
- Figure 2. MPO connector fiber counts	3
- Figure 3. MPO connectors and MPO adapter	3
- Figure 4. . MPO aligned-key and opposed-key adapters	3
CommScope fiber-optic cable	4
Product descriptions	4
- Data modules (DM)	4
- Visual identification of DM modules	4
- Figure 5. SYSTIMAX ULL DM module	4
SYSTIMAX ULL module variations	4
- Figure 6 . SYSTIMAX ULL 12-fiber MPO module	4
- Figure 7 . SYSTIMAX ULL 24-fiber MPO module	4
- Figure 8 . SYSTIMAX ULL 8-Fiber MPO module	4
MPO adapter panels (pass-through panels)	5
- Figure 9. MPO adapter panel	5
MPO-MPO trunk cables	5
MPO(f)-MPO(m) trunk extension cables	5
MPO-MPO cross-connect cables	5
Ruggedized fanout cables	6
Array/equipment cables	6
Enhanced Method B polarity management	6
- Figure 10. SYSTIMAX ULL module are orientated in the same direction at each end of the link	6
- Figure 11. SYSTIMAX ULL Enhanced Method B	6
SM ferrule angle and InstaPATCH 360 Method B	7
- Figure 12. SM MPO angle orientation	7
Typical MPO connectivity configurations for SYSTIMAX ULL systems	7
- Figure 13. SYSTIMAX ULL modules	7
Using trunk extension cables	7
- Figure 14. SYSTIMAX ULL extension cables	7
Using MPO-MPO array/ equipment cables	7
- Figure 15. SYSTIMAX ULL array/equipment cables	7
Using cross-connect cables	7
- Figure 16. SYSTIMAX ULL cross-connect cable	8
Using rugged or array fanout cables with trunks	8
- Figure 17. SYSTIMAX ULL MPO(f) fanout cable	8
Using rugged or array fanout cables with modules	8
- Figure 18. SYSTIMAX ULL MPO(m) fanout cable	8

The MPO connector, MPO pins, keys and polarity

The MPO connector was developed by NTT-AT in the mid-1980's and is internationally standardized in IEC 61754-7 as well as TIA/EIA 604-5. Both InstaPATCH 360 and SYSTIMAX ULL connectors are factory terminated in pinned and unpinned versions, as shown in Figure 1.

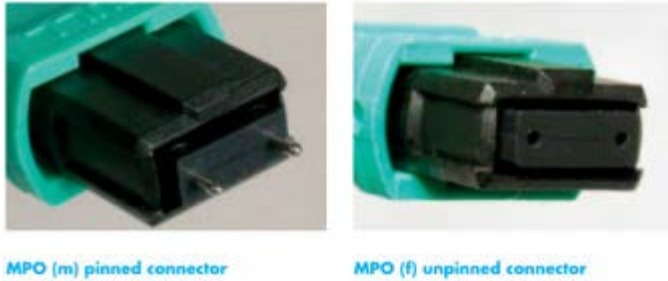

Figure 1. Pinned and unpinned MPO connectors

The pinned MPO is commonly referred to as male, or MPO(m), while the MPO without pins is referred to as female, or MPO(f). With the exception of the pins, the MPO connectors are identical. A pair of MPO connectors are mated by aligning the precision guide pins on the MPO(m) connector with the pin holes in the MPO(f) connector.

Depending on the application, MPO connectors are available in 8-fiber, 12-fiber or 24-fiber configurations. SYSTIMAX ULL Trunks and Modules are also available in 12-fiber and 8-fiber configurations see Figure 2.



Figure 2. MPO connector fiber counts

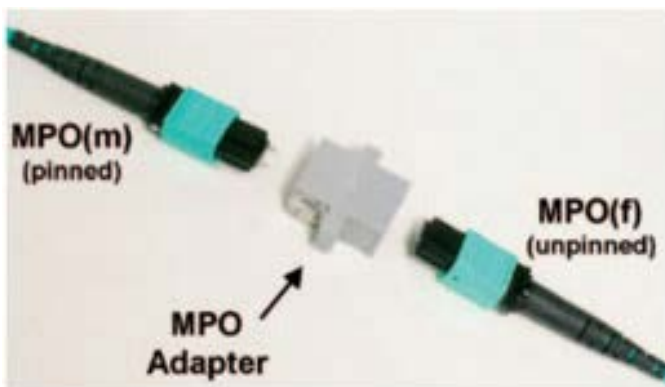

Figure 3. MPO connectors and MPO adapter

The MPO adapter provides coarse connector alignment and orientation, and includes retention features to secure the connectors. It is a passive device; it has no active components, no optical components and no precision alignment features (no pins, holes or sleeves).

Note that two female MPO connectors will insert and latch in an MPO adapter; however, due to the lack of the precision guide pins required for proper alignment, the two connectors will be misaligned resulting in significant channel loss. Conversely, two male MPO connectors will not insert and latch in an adapter without inflicting permanent damage to one or both of the connectors.

MPO connectors and adapters have interlocking lugs and notches (commonly referred to as "keys") that ensure proper orientation of the mating connectors. MPO Keys are a critical component of SYSTIMAX ULL Systems in assuring correct system polarity regardless of the network design topology. Polarity refers to the basic fiber optic design premise that every fiber must connect a signal source at one end to the proper signal receiver at the other end. Both Systems utilize Method B polarity control which uses "aligned key" MPO adapters. Key orientation on MPO connectors is established in the factory to implement specific polarity design criteria. SYSTIMAX ULL take advantage of the TIA/EIA FOCIS 5 adapter keying option k=2; commonly referred to as "aligned-keys" or "key-up to key-up." Therefore, an aligned-key adapter shall be present for each mated pair of MPO connectors in an SYSTIMAX ULL link. Aligned-key adapters are easily recognized by their light gray color, opposed-key adapters are black in color, as shown in Figure 4.



Aligned-key MPO Adapter
(also known as
"key-up to key-up adapter")

Opposed-key MPO Adapter
(also known as "key-up to
key-down adapter")

Figure 4. . MPO aligned-key and opposed-key adapters

CommScope fiber-optic cable SYSTIMAX ULL module variations

SYSTIMAX ULL products use CommScope TeraSPEED® (OS2), LazrSPEED® 550 (OM4), LazrSPEED 550 Wide Band (OM5) or TeraSPEED (ZWP) fiber. LazrSPEED 300 and 550 products are identified with an aqua color and LazrSPEED 550 Wide Band are lime green and TeraSPEED is yellow.

SYSTIMAX ULL cable assemblies are available in 8-fiber, 12-fiber or 24-fiber round (IPD) cordage types up to a total of 144 fibers.

Product descriptions

Data modules (DM)

Modules are self-contained cable assemblies within a plastic housing that transition MPO connectors on the back into duplex LC connectors on the front.

SYSTIMAX ULL modules contain a female MPO connector. SYSTIMAX ULL Systems use the same modules on both ends of a link are in the same orientation.

TeraSPEED modules are blue, LazrSPEED 550 modules are aqua, LazrSPEED 550 Wide Band modules are lime green.

Visual identification of DM modules

SYSTIMAX ULL DM modules have a squared off housing with a large colored bulkhead on the back which denotes fiber type. SYSTIMAX ULL DM modules may have 1, 2 or 3 MPO adapters on the back. SYSTIMAX ULL DM modules may also be identified by gray colored latch assists on the front, see Figure 5.



Figure 5. SYSTIMAX ULL DM module

In addition to multiple fiber types, SYSTIMAX ULL Modules are also available with one 24-fiber, two 12-fiber or three 8-fiber MPOs on the back and all SYSTIMAX ULL DM Modules have 24 LCs on the front arranged in 12 Duplex LC Ports differently based on MPO type.

SYSTIMAX ULL modules with 12-fiber MPOs are numbered 1 and 2 and the Duplex LC ports are numbered 1-12 starting in the lower left corner. Fibers in MPO Port 1 correspond to duplex LC ports 1-6 (bottom row), whereas fibers in MPO Port 2 correspond to duplex LC ports 7-12 (top row), see Figure 6.



DM12-24LC-TS-ULL

Figure 6 . SYSTIMAX ULL 12-fiber MPO module

SYSTIMAX ULL modules are also available with a single 24-fiber MPO on the back. The duplex LC ports are numbered 1-12 starting in the lower left corner (same as 12-fiber MPO version), see Figure 7.



DM24-24LC-WB-ULL

Figure 7 . SYSTIMAX ULL 24-fiber MPO module

SYSTIMAX ULL modules are available with three 8-fiber MPOs on the back. On this version the duplex LC ports are arranged differently. They are arranged in 3 groups of 4, identified by the color of the shutter doors. The duplex LC ports within each group are numbered 1-4 starting in the upper left corner and ending in the lower right. Each group of LC ports corresponds to 1 of the 8-fiber MPOs on the back. Starting on the left, the 1st group of LC ports correspond to MPO 1, the middle group to MPO 2 and the last to MPO 3, See Figure 8.



DM08-24LC-TS-ULL

Figure 8 . SYSTIMAX ULL 8-Fiber MPO module

MPO adapter panels (pass-through panels)

MPO adapter panels are panels that mount into shelves similarly to modules and contain up to 8 aligned-key MPO adapters. These are used to connect trunk cables to equipment cords or fanout cables. SYSTIMAX ULL use MPO adapter panels, see Figure 9.



360DP-8MPO

Figure 9. MPO adapter panel

MPO-MPO trunk cables

Trunk cables are high density ruggedized fiber cables used to distribute large numbers of fiber from one area of installation to another. Trunk cables have between 1 and 24 subunits surrounded by a ruggedized over jacket. Subunits can contain 8, 12 or 24 fibers. SYSTIMAX ULL Trunks are available in multiples of 8, 12 or 24 fibers up to a total of 288 fibers.

All SYSTIMAX ULL trunk cables follow Type B polarity.

MPO-MPO trunk cables	End A	End B
Connects to	SYSTIMAX ULL modules or MPO adapter panels	SYSTIMAX ULL modules or MPO adapter panels
Connector type	Male pinned MPO	Male pinned MPO

MPO(f)-MPO(m) trunk extension cables

Extension cables are used to extend the reach of a trunk cable. Extension cables share the same construction and are available with the same options as trunk cables with one exception; trunk extensions have female MPOs on one end and male MPOs on the other. One end will be mated to a trunk and the other end can be mated to a module, fanout or equipment cord.

MPO-MPO trunk extension cables	End A	End B
Connects to	SYSTIMAX ULL trunks	SYSTIMAX ULL modules or MPO adapter panels
Connector type	Female unpinned MPO	Male pinned MPO

MPO-MPO cross-connect cables

Cross-connect cables serve the function of an array “jumper” between two MPO trunks terminated in MPO adapter panels. Cross-connect cables share the same construction and are available with the same options as trunk and extension cables.

MPO-MPO cross-connect cables	End A	End B
Connects to	SYSTIMAX ULL trunks	SYSTIMAX ULL trunks
Connector type	Female unpinned MPO	Female unpinned MPO

Ruggedized fanout cables

Ruggedized Fanout Cables, also known as hydra cables, direct attach or breakout cables are used to transition MPO connectors into simplex or duplex connectors for direct connection to electronic equipment. Depending on application Fanout cables can be configured with either a male or female MPO. Care must be taken to order the correct Fanout type or an incompatible mating will result. Ruggedized Fanout cables use the same cable protection jacket as trunks cables, but the total fiber count is limited to 72. Ruggedized Fanout Cables are recommended when cables will be run in between cabinets or in overhead pathways for example.

Ruggedized fanout cables	End A	End B
Connects to	SYSTIMAX ULL trunks or SYSTIMAX ULL modules	Active equipment
Connector type	Male pinned or female unpinned MPO	LC

Array/equipment cables

Array cables, also known as equipment cables, are light duty, single subunit cables used to connect trunks or modules to electronic equipment. Array cables can be configured with MPO connectors on both ends, or on just one end with simplex or duplex connectors on the other. Array cables are recommended for use within protected patching areas – within a cabinet for example. SYSTIMAX ULL array cords are available with 8-fiber, 12-fiber or MPO connectors. 8-fiber and 12-fiber cords are 3.0mm in diameter and 24-fiber cords are 3.6mm. SYSTIMAX ULL MPO-MPO Array Equipment Cables have female MPO connectors on each end, thus eliminating the possibility of plugging a male MPO into and damaging electronic equipment.

Array fanout cables	End A	End B
Connects to	SYSTIMAX ULL trunks or SYSTIMAX ULL modules	Active equipment
Connector type	Male pinned or female unpinned MPO	LC

Array equipment cables	End A	End B
Connects to	SYSTIMAX ULL trunks	Active equipment
Connector type	Female unpinned MPO	Female unpinned MPO

Enhanced Method B polarity management

SYSTIMAX ULL uses Enhanced Method B Polarity, Method B trunks and aligned key adapters, see Figures 10 and 11.



Figure 10. SYSTIMAX ULL module are orientated in the same direction at each end of the link

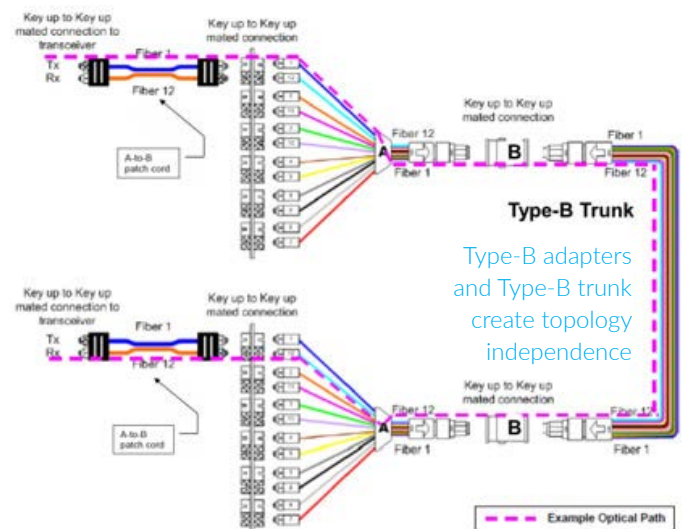

Figure 11. SYSTIMAX ULL Enhanced Method B

SM ferrule angle and InstaPATCH 360 Method B

SM MPO connectors are polished with an 8° angle on the connector ferrule. This angle is there to improve Return Loss (RL) performance, giving RL measurements of -55dB or better. Since Method B polarity requires the use of aligned key MPO adapters, male and female MPO connector used in SYSTIMAX ULL cable assemblies are angled in opposite directions. Male MPO connectors (MX) are angled UP relative to the key and female connectors (MP) are angled DOWN, as illustrated in Figure 12.

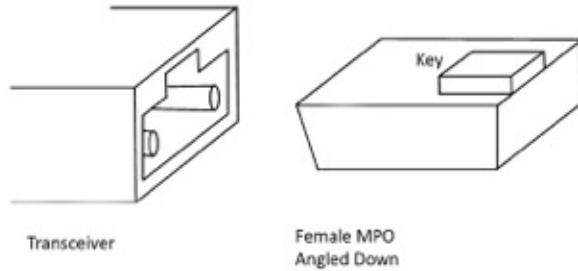

Figure 12. SM MPO Angle Orientation

These opposing angles ensure physical contact between fibers when the connectors are mated together, but a problem arises when female MPO connectors are inserted into electronic equipment. All SM MPO based transceivers were designed to accept female MPO connectors with down angles.

Typical MPO connectivity configurations for SYSTIMAX ULL systems

The simplest configuration connects 2 modules with a single trunk illustrated in figure 13.

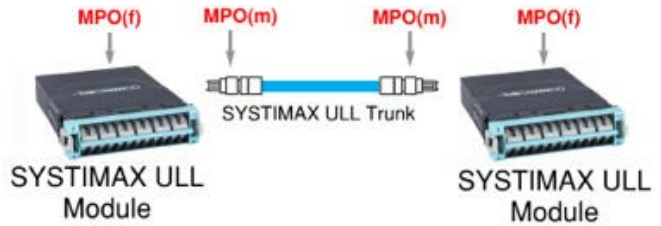

Figure 13. SYSTIMAX ULL modules

Using trunk extension cables

With use of an aligned-key MPO adapter extension cables can be used to increase the reach of existing trunks.

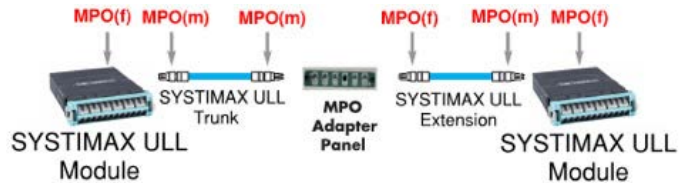

Figure 14. SYSTIMAX ULL extension cables

Using MPO-MPO array/equipment cables

Array/equipment cables connect to trunks to electronic equipment through MPO adapter panels.

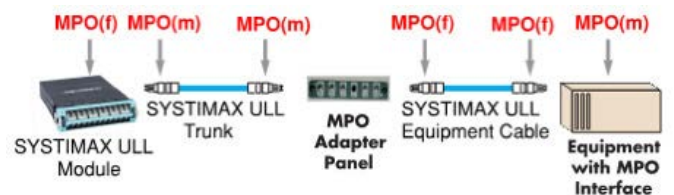

Figure 15. SYSTIMAX ULL array/equipment cables

Using cross-connect cables

Cross-connect Cables serve the function of an array “jumper” between two MPO Trunks terminated in MPO Adapter Panels, as illustrated in Figures 16.

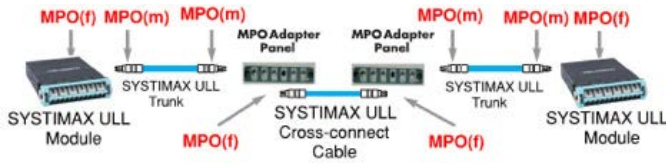

Figure 16. SYSTIMAX ULL cross-connect cable

Using rugged or array fanout cables with modules

When fanout cables mate to SYSTIMAX ULL modules, the fanout MPO must be male.



Figure 18. SYSTIMAX ULL MPO(m) fanout cable

Using rugged or array fanout cables with trunks

Fanout cables are available with either male MPO or female MPO connectors for nearly unlimited network design possibilities. The network designer must correctly specify the MPO pin configuration. When fanout cables mate to SYSTIMAX ULL trunks, the fanout must have a female MPO connector.

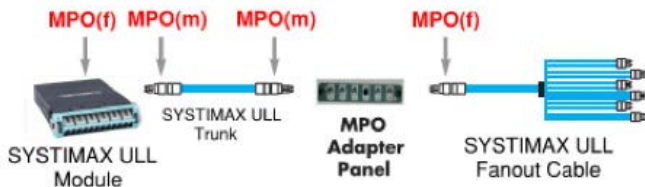

Figure 17. SYSTIMAX ULL MPO(f) fanout cable

Everyone communicates. It's the essence of the human experience. *How* we communicate is evolving. Technology is reshaping the way we live, learn and thrive. The epicenter of this transformation is the network—our passion. Our experts are rethinking the purpose, role and usage of networks to help our customers increase bandwidth, expand capacity, enhance efficiency, speed deployment and simplify migration. From remote cell sites to massive sports arenas, from busy airports to state-of-the-art data centers—we provide the essential expertise and vital infrastructure your business needs to succeed. The world's most advanced networks rely on CommScope connectivity.

COMMScope®

commscope.com

Visit our website or contact your local CommScope representative for more information.

© 2017 CommScope, Inc. All rights reserved.

All trademarks identified by ® or ™ are registered trademarks or trademarks, respectively, of CommScope, Inc. This document is for planning purposes only and is not intended to modify or supplement any specifications or warranties relating to CommScope products or services. CommScope is committed to the highest standards of business integrity and environmental sustainability, with a number of CommScope's facilities across the globe certified in accordance with international standards, including ISO 9001, TL 9000, and ISO 14001. Further information regarding CommScope's commitment can be found at www.commscope.com/About-Us/Corporate-Responsibility-and-Sustainability.

TP-111935-EN (06/17)