

ITEM	PART NO.	DESCRIPTION	QTY.	WEIGHT
1	MTF1542.02	SELF SPLICING COAX COVER (4 RUN COAX)	1	50.19 LBS
2	MTF1543.02	SELF SPLICING COAX COVER (8 RUN COAX)	1	77.89 LBS
3	MT-F1600	PVC ROOF SLEEPER FOR 12 RUNS OF COAX	3	3.85 LBS
4	MTF1595HK	HARDWARE KIT (ITEMS 5-7)	1	
5	GB-03125	3/8" X 1-1/4" GALV BOLT KIT	10	0.64 LBS
6	GWF-03	3/8" GALV FLAT WASHER	20	0.07 LBS
7	MTF1542.03	ROOF TOP COVER CLIP	6	0.49 LBS

REVISIONS				
REV.	ZONE	DESCRIPTION	BY	DATE
A		INITIAL RELEASE	JTS	04/27/01
B		UPDATE ROOFTOP COVER CLIP, COVER CHANGED TO SELF SPLICING, ADDED SPLICING FASTENERS	ACG	02/02/06
C		ADDED HOLE TO ITEM 7	ACG	03/06/06
D		CHANGE HARDWARE KIT PART NUMBER	ACG	04/19/06
E		ADDED TO BOLT KITS & FLAT WASHER QTY	ACG	08/16/06

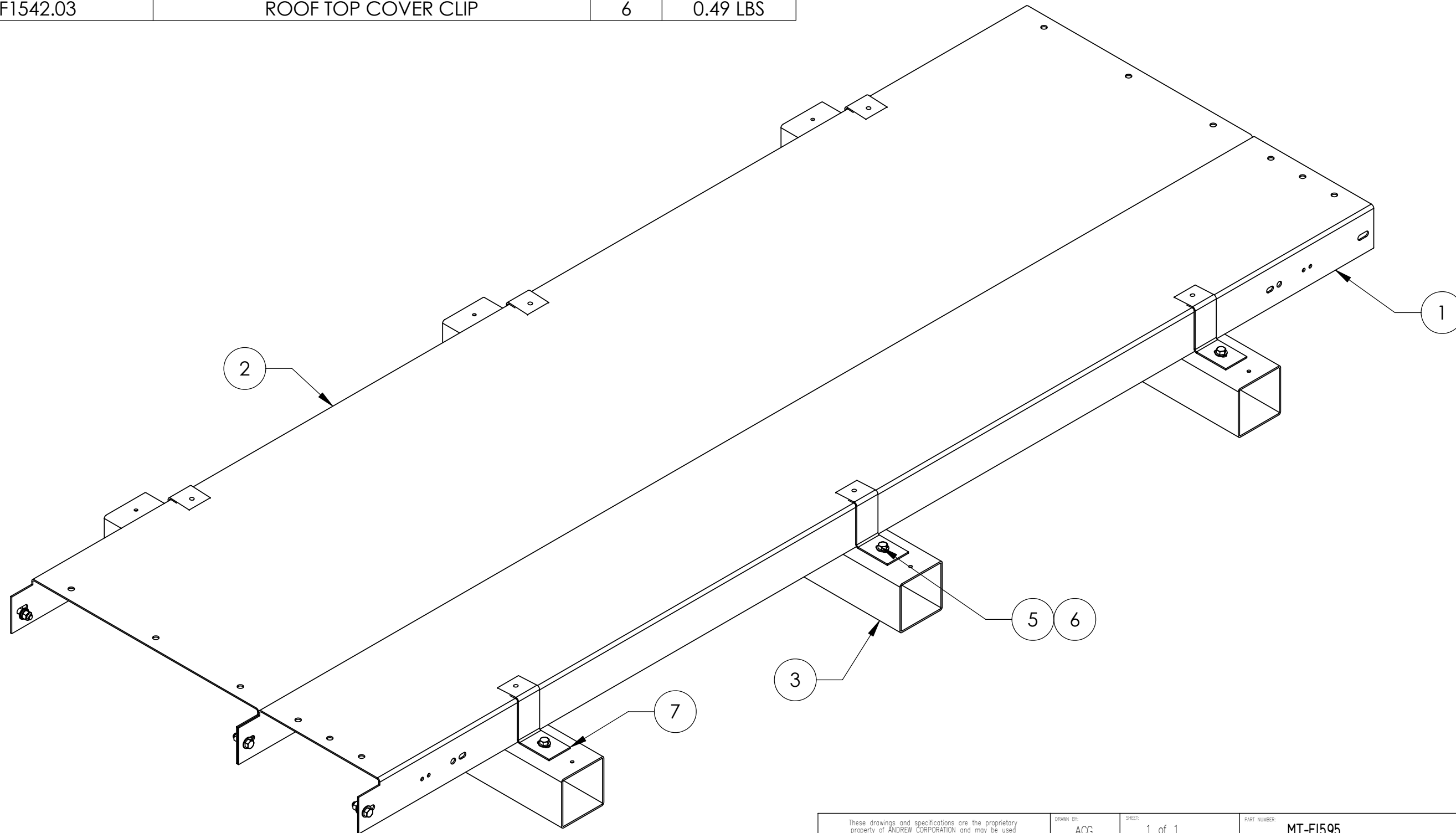

NOTES:

1. $\phi 5/16$ " HOLE INCLUDED IN ITEM 7 FOR OPTIONAL (NOT INCLUDED) $1/4$ " SELF-DRILLING SCREW.

<small>These drawings and specifications are the proprietary property of ANDREW CORPORATION and may be used only for the specific purpose authorized in writing by Andrew Corporation.</small> ALL DIMENSIONS ARE IN INCHES U.O.S. TOLERANCES UNLESS OTHERWISE SPECIFIED: .X = $\pm .06$ ANGLES $\pm 2'$.XX = $\pm .03$ FRACTIONS $\pm 1/32$.XXX = $\pm .010$ REMOVE BURRS AND BREAK EDGES .005 DO NOT SCALE THIS PRINT	DRAWN BY: ACG	SHEET: 1 of 1	PART NUMBER: MT-F1595
	CHECKED BY: TP	SCALE: NTS	DESCRIPTION: SELF SPLICING ROOF TOP BRIDGE KIT (12 RUN COAX)
	DATE: 02/02/06	MATERIAL: A568	DRAWING TYPE: ASSEMBLY DRAWING
	REVISION: E	FINISH: GALV A123	WEIGHT: 143.57 LBS