

ON-TRAY-PATCHING IN A FIST MK2 SYSTEM

Contents

1. Kit content.....	1	4. Install LC connectors	2
2. Patch tray functionalities.....	1	5. Disconnect a connector	2
3. Install SC connectors	1	6. Accessories (to be ordered separately)	2

1. Kit content

#	Description	Amount
1	Groove plate with 6 UMS units	1
2	Patch tray	2

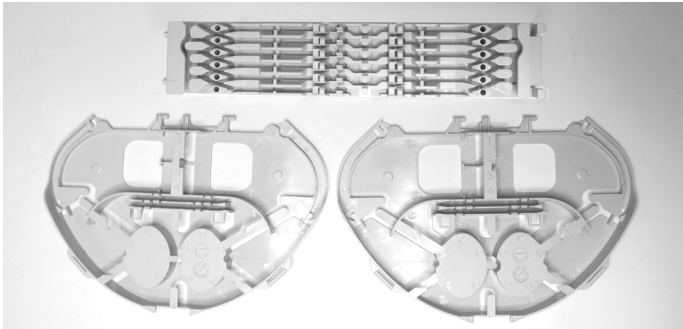

2. Patch tray functionalities

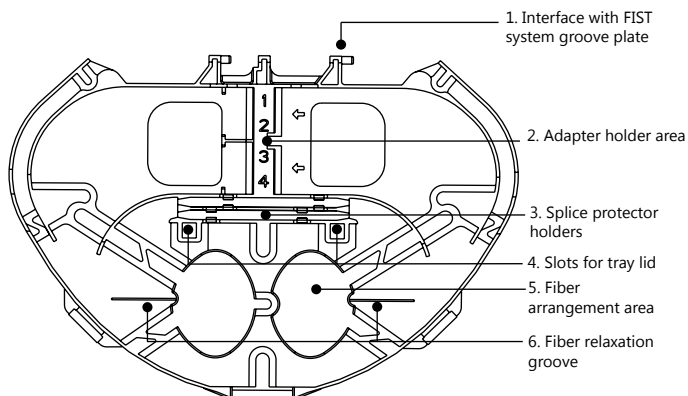

1. The tray has the same snapping interface as other FIST trays to install it in the groove plate. Refer to instructions **TC-574-IP** to install the tray. Tray thickness is **3 UMS units**.

Remark: Tray can be installed at position 1 or on top of other FIST trays without leaving a gap. When building a tray (all FIST trays) on top of a patch tray, 2 grooves (2 UMS units) need to be left open in between.

2. Two adapters can be installed in this area. The adapter type can be LC or SC (**flangeless**).
 LC adapter types are LC duplex adapters. The tray has a maximum capacity of **4 LC connections**.
 SC adapter types are SC simplex adapters. The tray has a maximum capacity of **2 SC connections**.

3. The tray contains 2 holders for splice protectors, each holder holds up to 4 heat shrink splice protectors (**SMOUV 45 mm**). Providing a maximum capacity to store **8 heat shrink splice protectors** on the tray.

4. In the tray there are 2 slots to install the standard tray lid on top of the patch tray (only when the tray is in top position).

5. Over-length is stored in the Fiber arrangement area of the tray. 900µm fiber as well as 250µm fiber are stored in this area.

6. Use the fiber guidance pin in the grooves to relax the fibers when routed tight around the islands.

3. Install SC connectors

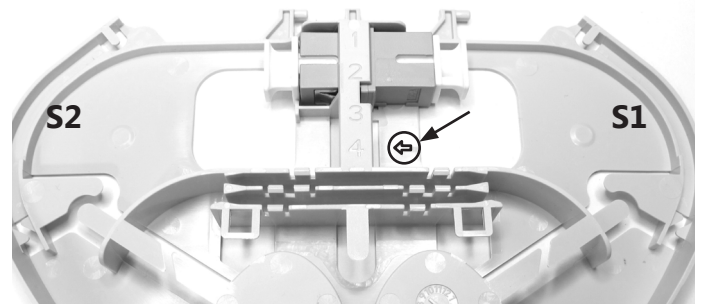

3.1. Slide the SC adapter in the tray. Slide it from side S1 to side S2. Verify the proper orientation of the adapter: U-slots facing upwards and metal spring facing towards side S2.



3.2. Route the two fibers that need to be connected to the patch tray as described in instructions **TC-574-IP**. Verify the length of the fiber. The maximum storage capacity is **75cm +/- 5cm**.

3.3. Verify the length of the patch cord. The length must be **75cm +/- 5cm**.

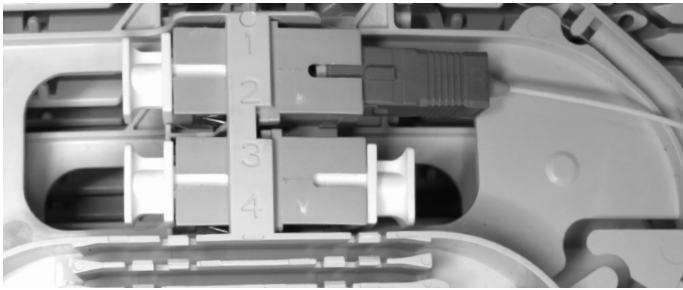

3.4. Remove the dust caps of both, the adapter and the connector, and make connection until fully seated (observe a clicking sound). Make sure the rib on the connector is facing upwards. **Note:** Cleaning connectors is recommended.

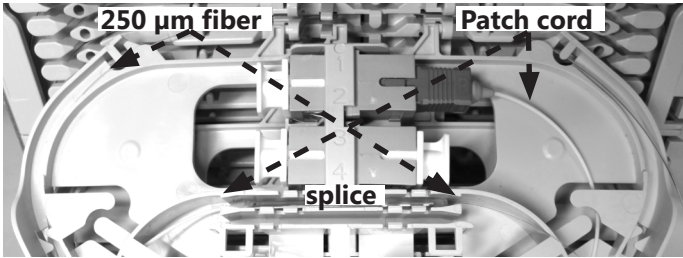

3.5. Splice the patch cord to one of the two fibers on the tray per standard practice. Store the splice protector centered in the splice holder (verify position of the fiber/patch cord when positioning the splice in the holder). **Note:** Avoid short fiber bends when leaving the splice holder.



3.6. Store over-length of both patch cord and 250μm fiber on the tray. **Make sure the fibers are not routed too tight around the islands** (use the fiber relaxation grooves to provide the largest possible diameter to the fibers) and make sure all fibers are properly positioned under the lips. If required the fiber (250μm) can make an S-shaped U-turn using the openings between the two islands (see dotted line). Avoid fiber routing over a single island only.

3.7. Repeat step 3.2 until 3.6 to connect the other fiber to the patch cord of the connector installed in the opposite side in the adapter.

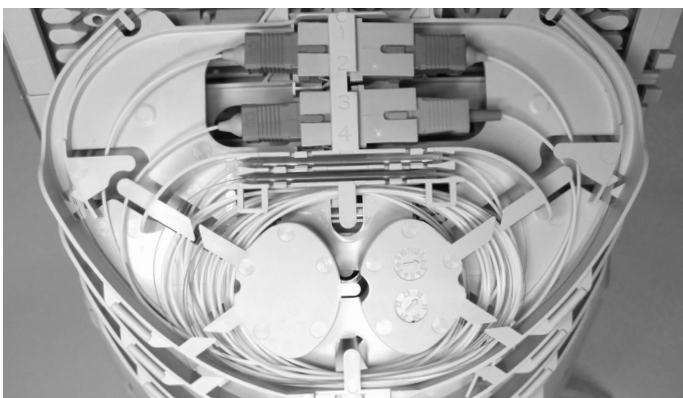

3.8. Up to 2 patch connections can be made when using SC connectors. See fully loaded tray above.

4. Install LC connectors

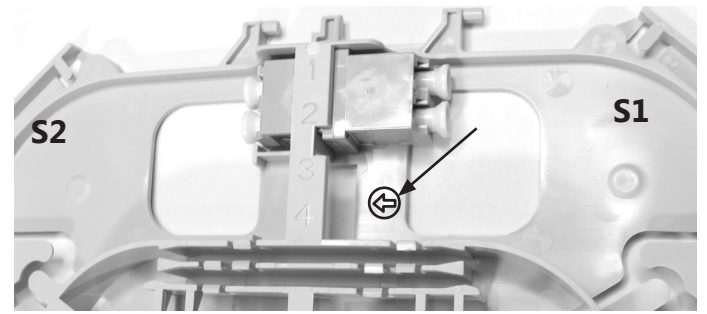

4.1. Slide the LC duplex adapters in the tray. Slide it from side S1 to side S2. Verify the proper orientation of the adapter. Slots for locking tabs at the top.

4.2. Proceed with steps 3.1 and 3.3 until 3.7 to connect 2 fibers through patching.

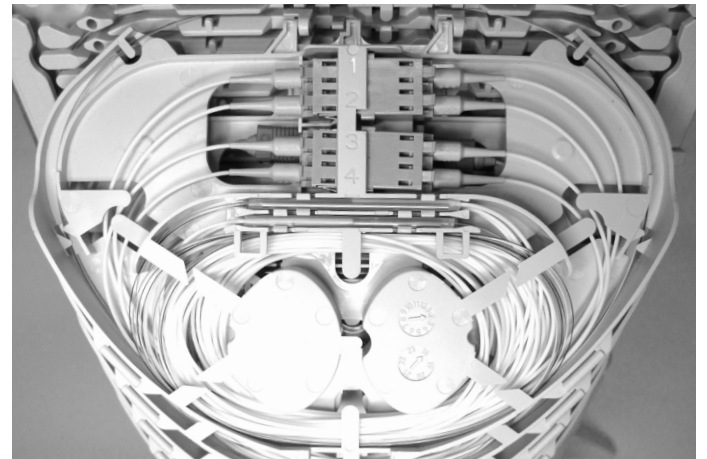

4.3. Up to 4 patch connections can be made when using LC connectors. See fully loaded tray above.

5. Disconnect a connector

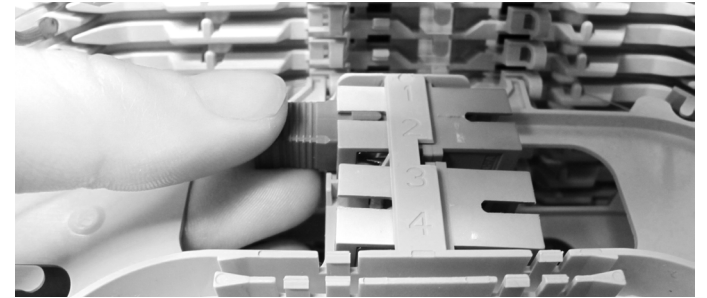

5.1. To disconnect a connector, the connector can be accessed through the openings as shown.

6. Accessories (to be ordered separately)

Adapters:

Adapter type	Product description	Ordering number
Simplex SC/UPC	OC-ADP-S1-S1-NFCS-(24)	CP7687-000
Duplex LC/UPC	OC-ADP-L1-L1-NFCD-(24)	CP7688-000
Simplex SC/APC	OC-ADP-S2-S2-NFCS-(24)	CP7689-000
Duplex LC/APC	OC-ADP-L2-L2-NFCD-(24)	CP7690-000

Splice protectors:

SMOUV	SMOUV-1120-02-PK	418280-000
-------	------------------	------------