

REVISIONS			
REV.	DESCRIPTION	DATE	APPROVED
A	ECR 800008837: RELEASE TO PRODUCTION.	26JUN15 LS	HV/XA
C	ECR 8000010857: ADD DIMENSIONS.	10NOV15 LS	S.LIU/JIHE
D	ECR 8000037116: ADD DIMS.	29AUG19 DXJ	KDI/ZH.JIAN
E	ECR 8000039485: REMOVE BSAMNT-1; UPDATE DRAWING WITH LATEST MODEL FOR BSAMNT-3.	29FEB20 ZW	S.LIU/HANSEN.W
F	ECR 8000042375: UPDATE DRAWING WITH LATEST MODEL.	02SEP20 CN	PL.TANG/HANSEN.W

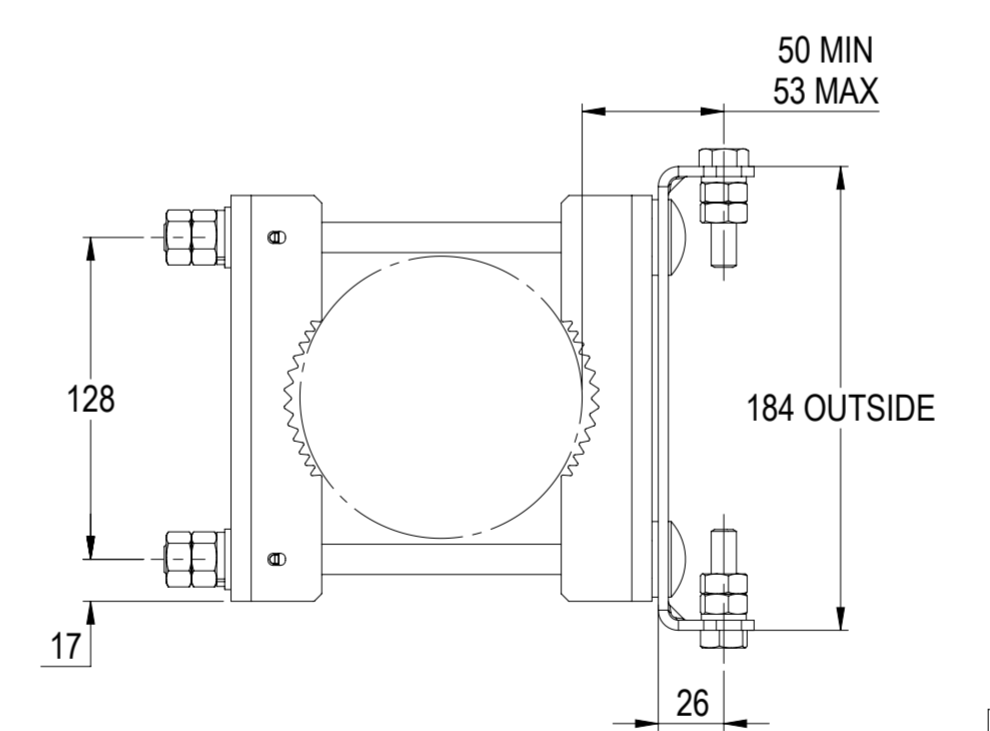
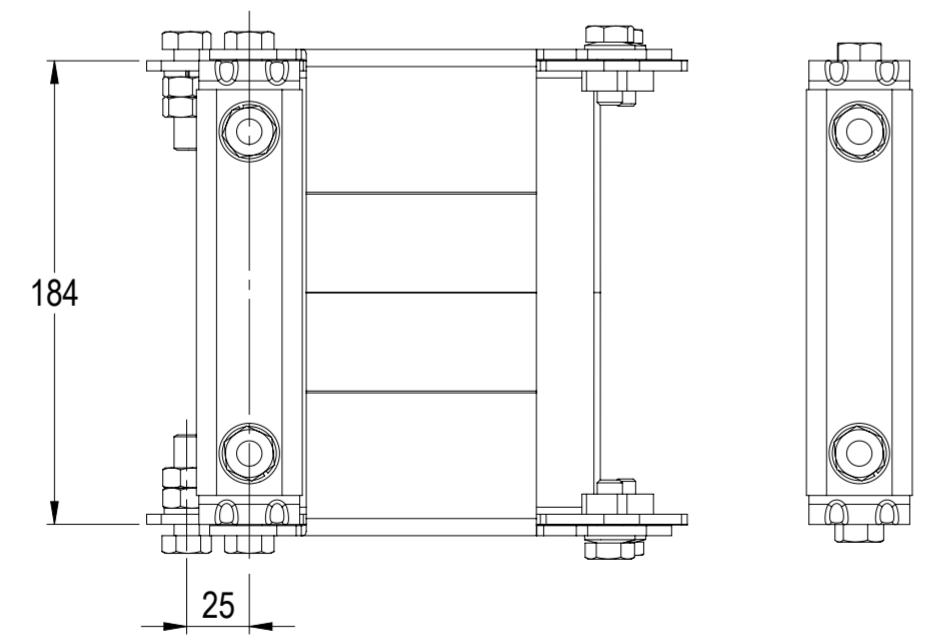
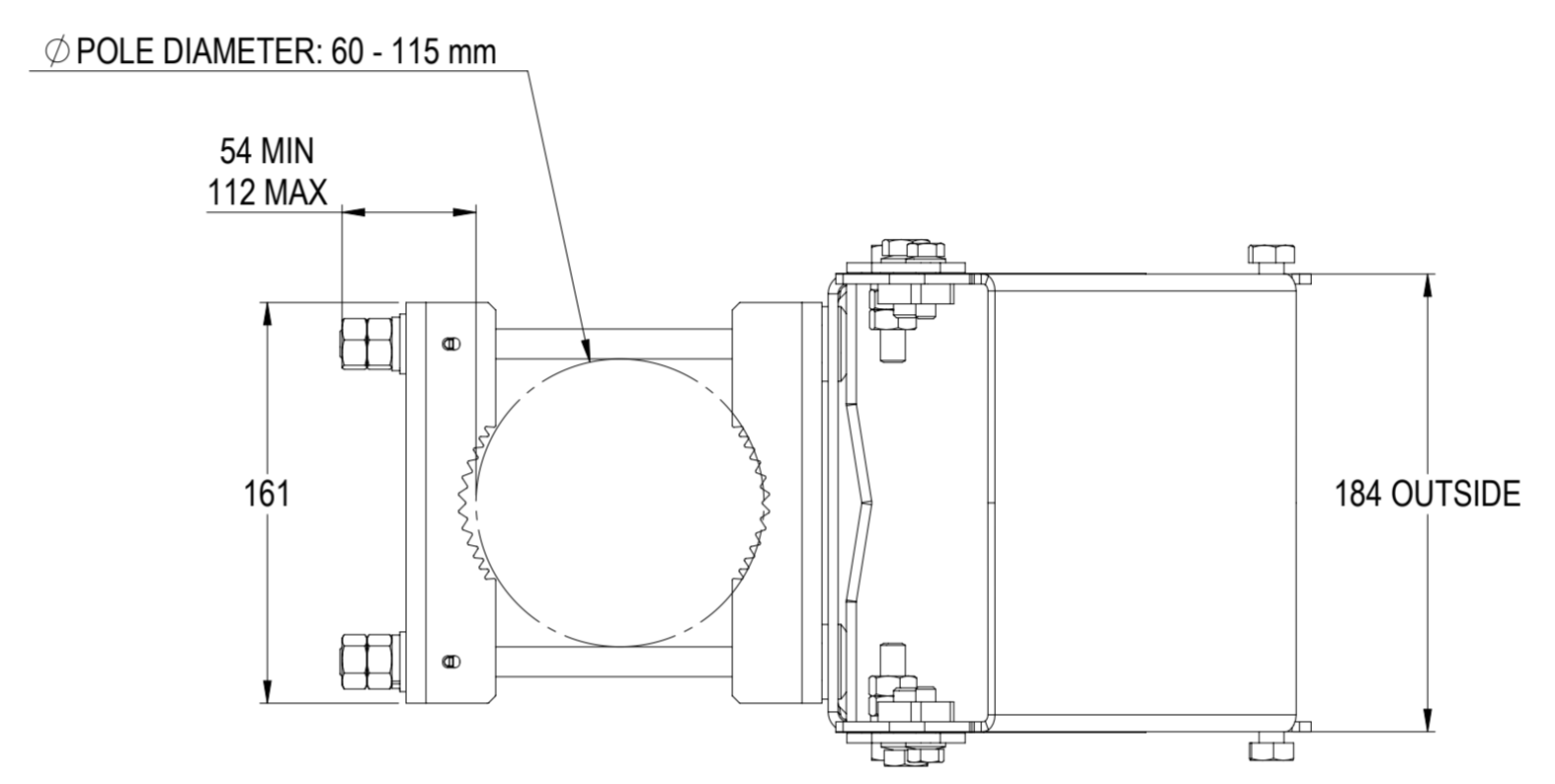
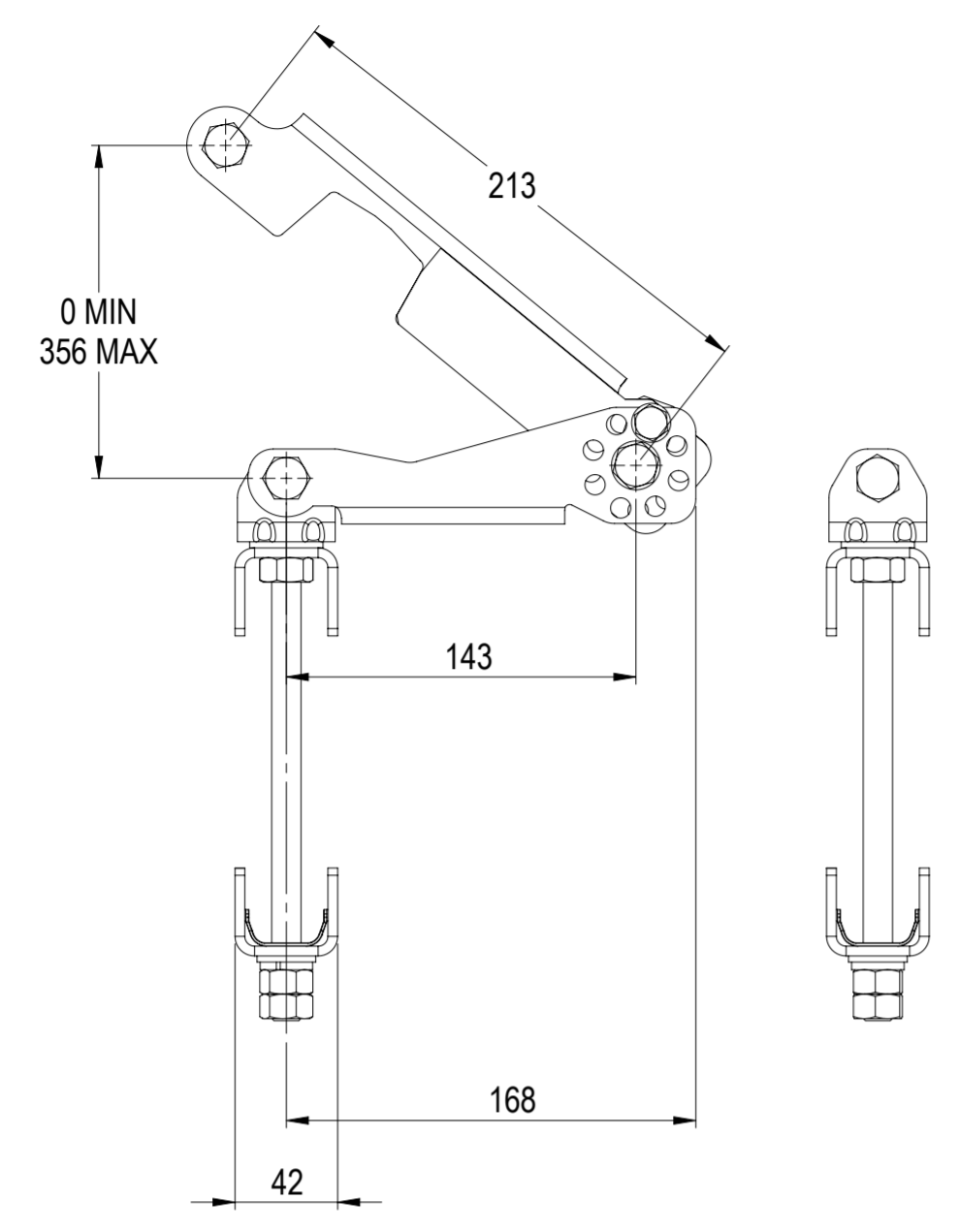

# BSAMNT-3

DENSITY	g/mm <sup>3</sup>
MASS	kg
VOLUME	mm <sup>3</sup>
SURFACE AREA	mm <sup>2</sup>
HEIGHT	
LENGTH	
WIDTH	

**COMMSCOPE, INC. OF NORTH CAROLINA**

TOLERANCES: 0 PLACE X ±, 1 PLACE .X ±, 2 PLACE .XX ±, ANGLES ±

SAP MATERIAL MASTER

FINISH: N/A, MATERIAL: N/A

NAME	DATE	TITLE
CE LS	06/26/2015	<b>PRODUCT DRAWING</b>
RW NC1020	09/04/2020	
RV PLTANG	09/08/2020	
AD HW8003	09/08/2020	
RE ZHHCHEN	09/09/2020	

SCALE: 1:3, DOCUMENT NO.: **BSAMNT-3-L**

SIZE: <b>A2</b>	WORK AREA: 23	MODEL: 05 RE	REVISION: F	VERSION: 05	STATUS: RE	REVISION: F	SHEET: 1 OF 1
-----------------	---------------	--------------	-------------	-------------	------------	-------------	---------------

UNLESS OTHERWISE SPECIFIED DIMENSIONS ARE IN MILLIMETERS INTERPRET PER ISO STANDARDS HANDBOOK TECHNICAL DRAWINGS VOLUMES 1 & 2, THIRD EDITION (2002)