

R7PNM



Type N Male Low PIM for 1-5/8 in RCT RADIAX® Radiating cable

Product Classification

Product Type	Wireless and radiating connector
Product Brand	RADIAX®

General Specifications

Body Style	Straight
Cable Family	RCT7
Inner Contact Attachment Method	Thread-in stub
Inner Contact Plating	Silver
Interface	N Male
Mounting Angle	Straight
Outer Contact Attachment Method	Clamp
Outer Contact Plating	Trimetal
Pressurizable	No

Dimensions

Length	112.01 mm 4.41 in
Diameter	62.99 mm 2.48 in
Nominal Size	1-5/8 in

Outline Drawing

R7PNM

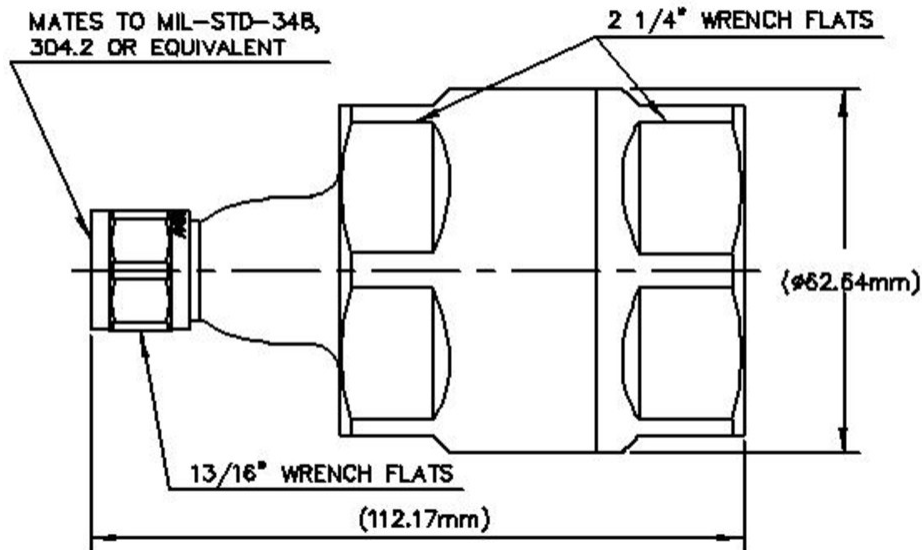

Electrical Specifications

3rd Order IMD at Frequency	-107 dBm @ 910 MHz
3rd Order IMD Test Method	Two +43 dBm carriers
Insertion Loss Coefficient, typical	0.05
Average Power at Frequency	0.6 kW @ 900 MHz
Cable Impedance	50 ohm
Connector Impedance	50 ohm
dc Test Voltage	2000 V
Inner Contact Resistance, maximum	2 mOhm
Insulation Resistance, minimum	5000 MOhm
Operating Frequency Band	0 – 2700 MHz
Outer Contact Resistance, maximum	0.3 mOhm
Peak Power, maximum	10 kW
RF Operating Voltage, maximum (vrms)	707 V

VSWR/Return Loss

Frequency Band	VSWR	Return Loss (dB)
45–1000 MHz	1.141	23.63
1010–2000 MHz	1.228	19.8

R7PNM

2010–2400 MHz

1.29

18

Mechanical Specifications

Attachment Durability	25 cycles
Connector Retention Tensile Force	889.64 N 200 lbf
Connector Retention Torque	4.52 N-m 39.997 in lb
Coupling Nut Proof Torque	4.52 N-m 39.997 in lb
Coupling Nut Retention Force	444.82 N 100 lbf
Coupling Nut Retention Force Method	MIL-C-39012C-3.25, 4.6.22
Insertion Force	66.72 N 15 lbf
Insertion Force Method	MIL-C-39012C-3.12, 4.6.9
Interface Durability	500 cycles
Interface Durability Method	IEC 61169-16:9.5
Mechanical Shock Test Method	MIL-STD-202F, Method 213B, Test Condition C

Environmental Specifications

Operating Temperature	-55 °C to +85 °C (-67 °F to +185 °F)
Storage Temperature	-55 °C to +85 °C (-67 °F to +185 °F)
Attenuation, Ambient Temperature	20 °C 68 °F
Average Power, Ambient Temperature	40 °C 104 °F
Corrosion Test Method	MIL-STD-1344A, Method 1001.1, Test Condition A
Thermal Shock Test Method	MIL-STD-202F, Method 107G, Test Condition A-1, Low Temperature -55 °C

Packaging and Weights

Weight, net	846.18 g 1.866 lb
--------------------	---------------------

Regulatory Compliance/Certifications

Agency	Classification
ISO 9001:2015	Designed, manufactured and/or distributed under this quality management system



* Footnotes

Insertion Loss Coefficient, typical $0.05\sqrt{\text{freq}}$ (GHz) (not applicable for elliptical waveguide)

