

4

3

2

1

- 1.0 GENERAL NOTES
 - 1.1 ALL METRIC DIMENSIONS ARE IN BRACKETS [X.X]
 - 1.2 FOR PATENT INFO: <https://www.cs-pat.com>
- 2.0 DESIGN NOTES
- 3.0 MANUFACTURING/SPECIAL REQUIREMENTS
 - 3.1 TIGHTEN ALL BOLTS SECURING FLAT PLATES BY THE TURN-OF-NUT METHOD. TIGHTEN ALL U-BOLTS USING TURN-OF-NUT METHOD WITH ATTENTION TO LEAVE EQUAL DISTANCE AND EQUAL FORCE ON EACH LEG OF THE U-BOLT.
- 4.0 TEST
- 5.0 PACKAGING
 - 5.1 PACKAGING SHALL MEET COMMSCOPE REQUIREMENTS PER DOCUMENT IS-PL-3005
 - 5.2 PRINTED DOCUMENT TO BE PLACED INSIDE POLYBAG AND THEN IN SHIPPING CONTAINER
 - 5.3 EXTRA HARDWARE MAY BE SUPPLIED, BAGGED AND SHIPPED

REVISIONS			
REV.	DESCRIPTION	DATE	APPROVED
A	INITIAL RELEASE	DRR 16AUG11	
B	REDRAWN IN SOLIDWORKS	YMENG 06FEB24	BCROSS 40188554CMO

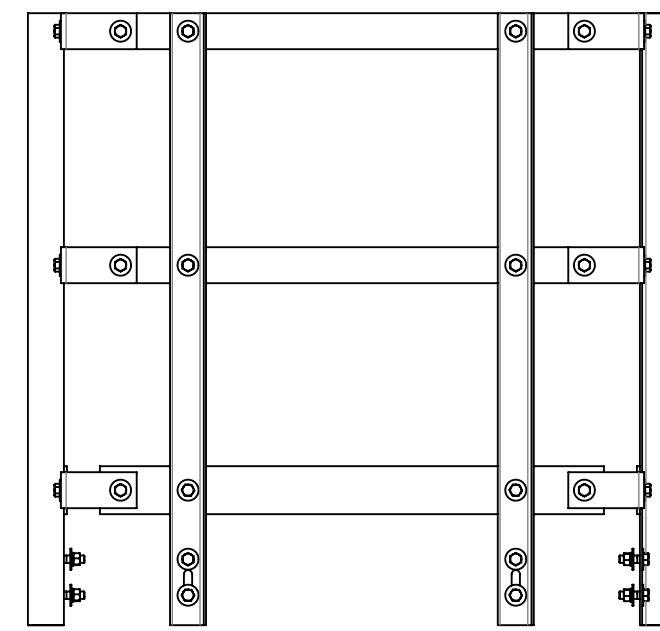
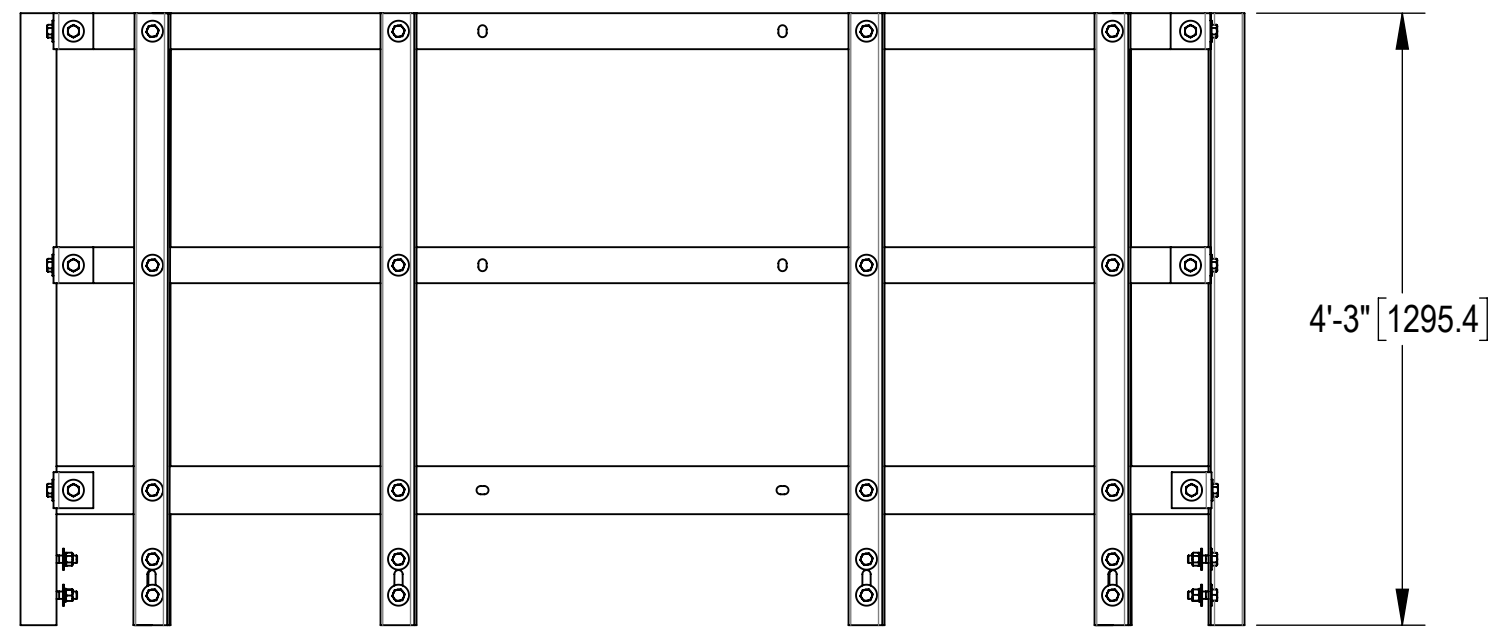
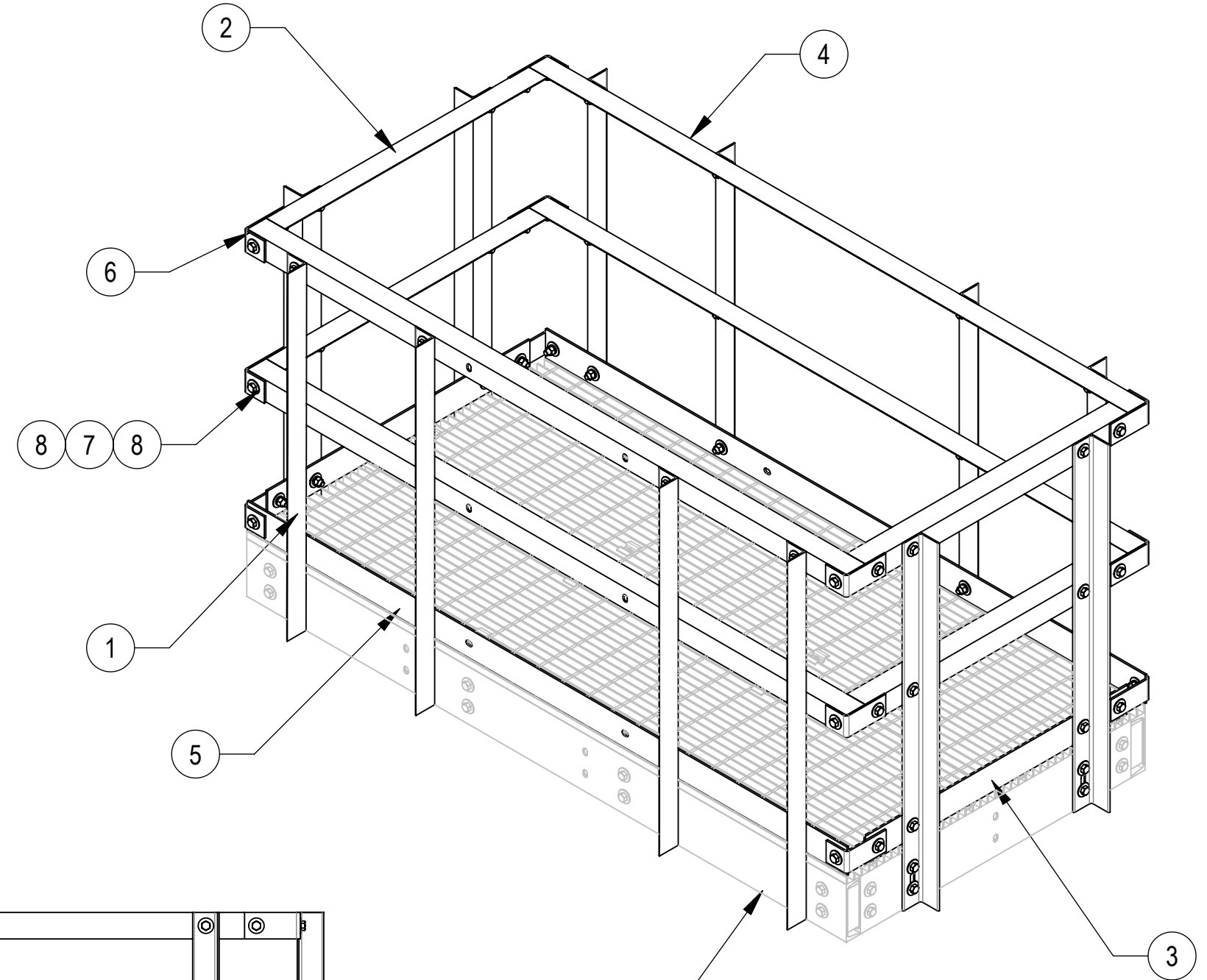
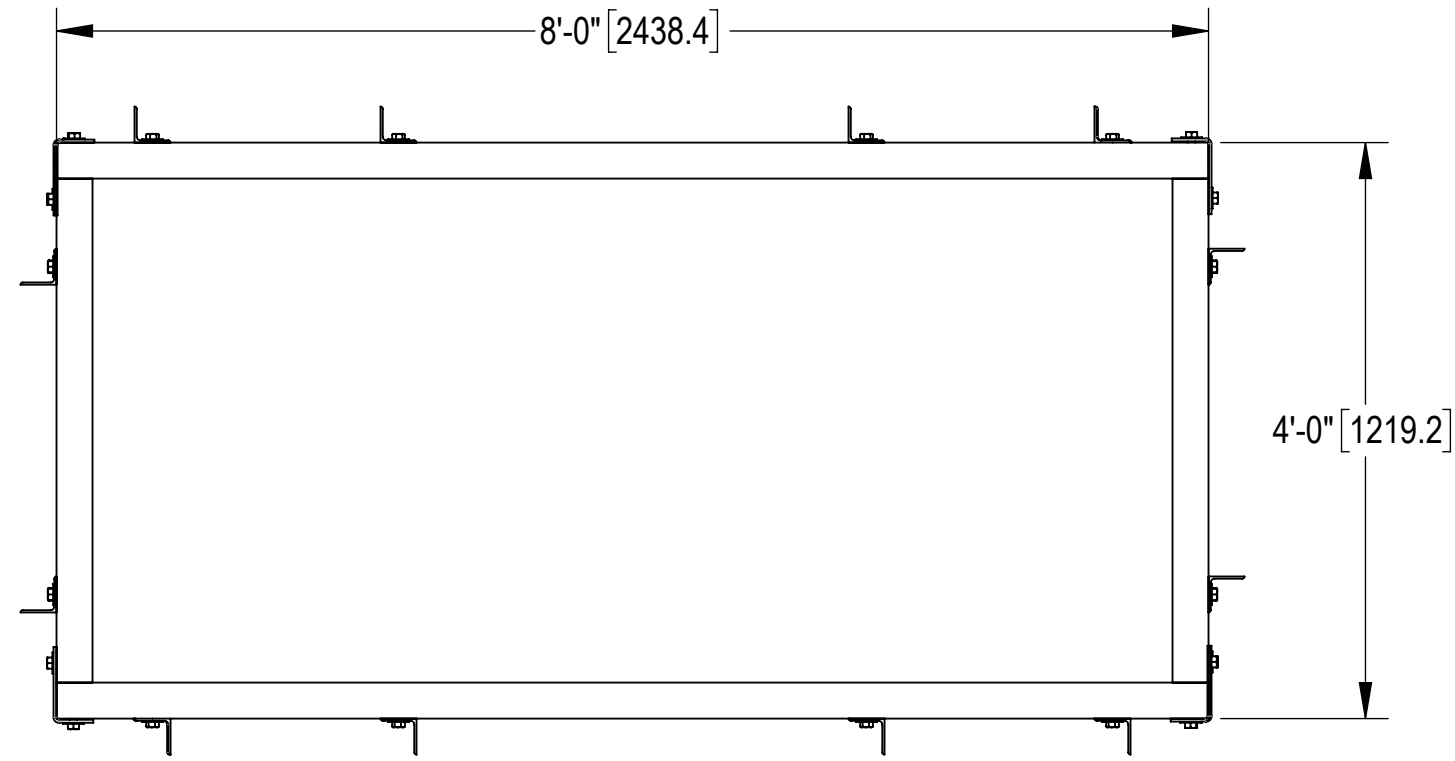

COMPONENT PART NUMBERS PROVIDED FOR ASSEMBLY PURPOSES;
INDIVIDUAL COMPONENTS MAY BE SHIPPED AS PARTS WITHIN AN INCLUDED KIT

ITEM	PART NO.	DESCRIPTION	QTY.	WEIGHT	NOTE NO.
1	EQHR01	HANDRAIL POST	12	15.52 LBS	
2	MTC7902041003	4' CENTER HANDRAIL	4	12.84 LBS	
3	MTC7902041004	4' CENTER TOEBOARD	2	11.67 LBS	
4	MTC7902080807	8' SIDE HANDRAIL	4	29.39 LBS	
5	MTC7902080808	8' SIDE TOEBOARD	2	26.72 LBS	
6	MTC790208	HANDRAIL ANGLE CLIP	12	1.87 LBS	
7	GB-05205	5/8" X 2" GALV BOLT KIT	84	0.26 LBS	
8	GWF-05	5/8" GALV FLAT WASHER, 1.7OD	168	0.06 LBS	

COMMSCOPE, INC. OF NORTH CAROLINA

TOLERANCES		SAP MATERIAL MASTER	
1 PLACE .X[X] ± 0.12[3.0]	3 PLACE .XXX[X] ± 0.030[0.8]	EQ-HR0408	
2 PLACE .XX[X] ± 0.06[1.5]	ANGLES ± 2°		
FINISH		MATERIAL	
UNLESS OTHERWISE SPECIFIED DIMENSIONS ARE IN INCHES INTERPRET PER ANSI Y 14.5M-1994	NAME	DATE	TITLE
	CE DRR	16AUG11	HANDRAIL FOR 4' X 8' EQUIPMENT PLATFORMS
	RW YMENG	02/07/2024	
	AD LL1090	02/08/2024	
	RE YMENG	02/08/2024	
ECN 40188554CMO			
SCALE	DOCUMENT NO.		
1:16	EQ-HR0408		
SIZE	Auth Group	INSL	MODEL
C			
	VERSION	STATUS	REVISION
	00	RE	B
	VERSION	STATUS	REVISION
	00	RE	B
	DRAWING		
	VERSION	STATUS	REVISION
	00	RE	B
	SHEET		
	1 OF 1		

4

3

2

1