

CM-SH30

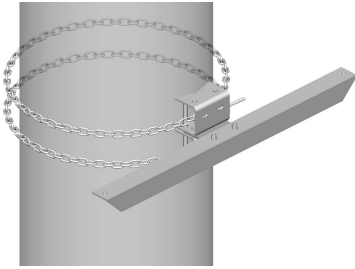

Heavy Duty Stiff Arm Mount, two 8 ft chains

Product Classification

Product Type Stiff arm mount

General Specifications

Chains, quantity 2

Dimensions

Height 152.4 mm | 6 in

Width 203.2 mm | 8 in

Length 1,168.4 mm | 46 in

Chain Length 2,400.3 mm | 94.5 in

Mounting Diameter, maximum 762 mm | 30 in

Mounting Diameter, minimum 203.2 mm | 8 in

Stand-off Distance 1,219.2 mm | 48 in

Mounting Circumference, maximum 2,392.68 mm | 94.2 in

Mounting Circumference, minimum 635 mm | 25 in

CM-SH30

Outline Drawing

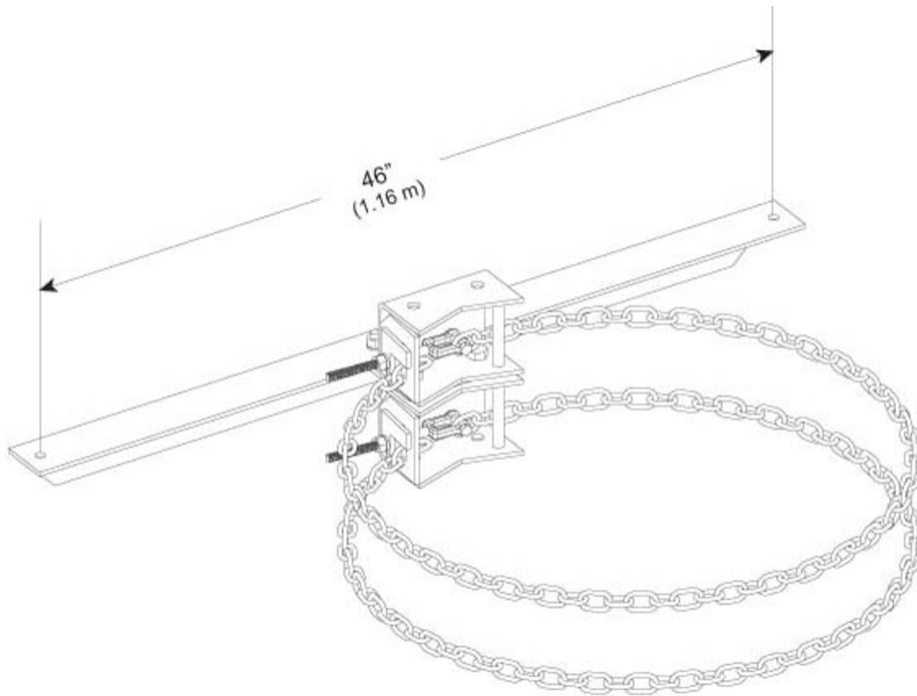

Material Specifications

Material Type Hot dip galvanized steel

Packaging and Weights

Included Chains | Stiff arm attachment

Packaging quantity 1

Weight, net 22.7 kg | 50.045 lb

Regulatory Compliance/Certifications

Agency	Classification
ISO 9001:2015	Designed, manufactured and/or distributed under this quality management system