



Voice and Data Coverage at Their Best



Andrew's Base Station Antennas, Tower Mounted Amplifiers, and Crossband Couplers for LTE Deployments in 700 MHz



Join the Evolution

Andrew, a CommScope Company, is a premier global supplier of RF footprint solutions for the wireless industry, known for our commitment to customers beyond the product sale. We provide a one-stop source for managing the entire lifecycle of a wireless network – from design through manufacturing and delivery – and offer complete solutions for wireless infrastructure, including top-of-the-tower base station antennas, cable systems and cabinets, RF site solutions, signal distribution, and network optimization.

Andrew is celebrated as a worldwide leader in “last mile” solutions. Combining innovative technologies, premier brands, and over 70 years of experience, we continue to expand our global service model and create an enhanced offering of communications infrastructure solutions that addresses a broader spectrum of customer needs.

After-sale support includes warranties, a full spectrum of program management and deployment services, and value-added support featuring certified training, system planning software, rapid access to technical specialists on a 24/7 basis, and an online resource library.

Why Andrew for LTE Deployment in 700 MHz?

Today, Andrew is recognized worldwide for our complete end-to-end solutions. Renowned for our technically advanced base station antenna systems, tower-mounted amplifiers (TMA), and crossband couplers (CBC), Andrew incorporates the multiple value-added features that have made us the preferred products of system managers, designers, and engineers around the globe.

- Designed with proven 850 MHz technology.
- Facilities located globally for easy deployment.
- Seamless integration into existing networks.
- Significant capability to design new products and quickly ramp up into full-scale production volume.
- Low profile design for easy zoning approvals.

Quality Assurance

Trust Andrew for consistent and reliable base station antenna products:

- 100% of our production antennas are tested in an anechoic environment for VSWR.
- 100% of our production antennas are tested in an anechoic chamber for Passive Intermodulation (PIM), during which each unit is subjected to a dynamic shock.
- 100% of our dual-polarized antennas are tested for isolation.

LNX-8513DS-VTM
DualPol® Single Band
Base Station Antenna

DB810KE-A
Omni-Directional
Base Station Antenna



DBXNH-6565A-VTM
DualPol® Dual Band
Base Station Antenna

DB844H90E-A
Directed Dipole™ Single Band
Base Station Antenna

Andrew Understands the 700 MHz Band Challenges

Application Issues to Consider

- Lower bandwidth will drive the size of the antennas.
- Applications will drive the priority for product development:
 - Capacity for urban deployments – 65° HBW.
 - Coverage for outlying areas – 90° HBW.
 - LTE considerations.
 - 2x2 or 4x4 MIMO application passive intermediate suppression.
- PIM may be a significant consideration.
- Deployment and construction.
- Risk minimization to the existing network performance during this rollout:
 - Match existing networks' RF footprint.

Andrew Base Station Antenna Portfolio

Andrew's base station antenna portfolio and core technical competencies provide our customers with a full suite of antenna solutions worldwide.

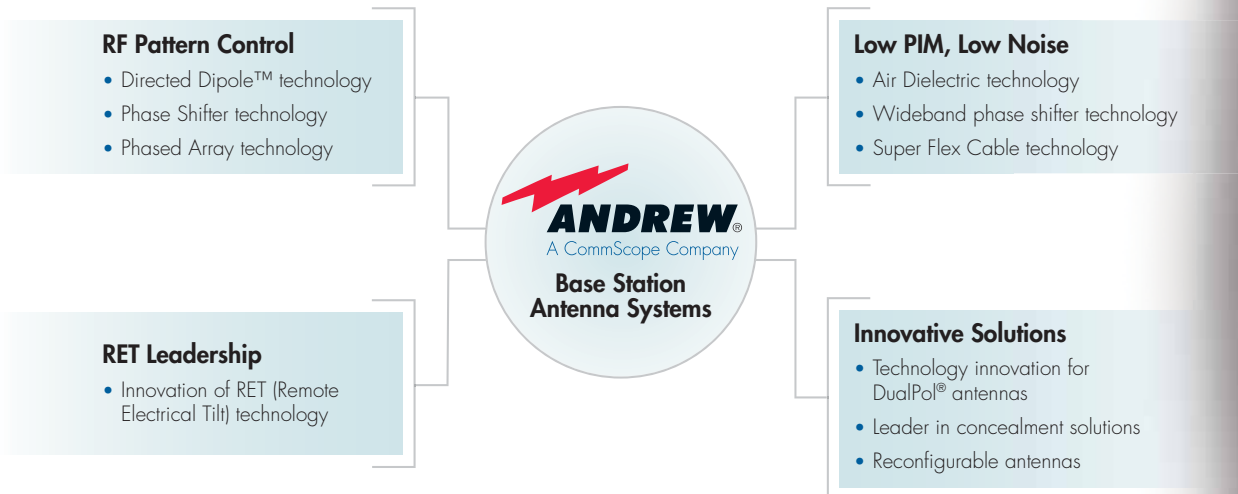

Proven Experience In Every Major Global Network Build-Out



700 MHz Band Application Considerations

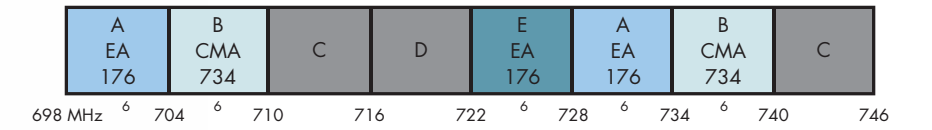

Upper 700 Band (746 – 806 MHz)

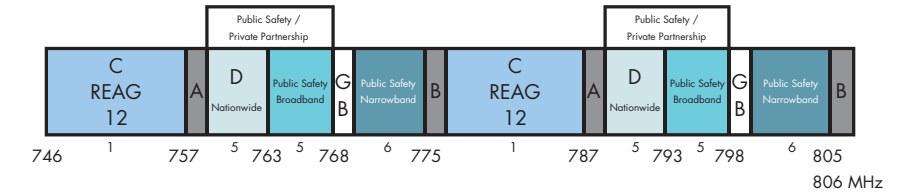

700 MHz Differentiating Factors

Andrew has set the standard with best-in-class PIM results, integrated proven 850 MHz technology into our designs, superior RF pattern performance, and electrical tilt management capability.

- Wideband 698–896 MHz antennas are capable of serving either lower or upper 700 MHz, as well as 850 MHz Cellular application.
- Designed using existing 806–960 MHz air dielectric technology, providing low loss with best-in-class PIM, which has scaled easily to the new frequency band. Nearly 1M antennas with this construction in use today!
 - DualPol® models available for both single band and dual band applications.
 - Dual band models are constructed with patented MART™ Microstrip ring dipole and are interleaved to offer a narrow width for ease in zoning. Each band is independently capable of electrical downtilt. Specially designed so there is no distortion of azimuth coverage when set to its full tilt position. 2–3 dB gain has been added to the 1710–2170 MHz band to compensate for pass loss differences between the 1710–2170 MHz and 700 MHz bands.
 - World leader in the development of variable electrical downtilt for over 10 years with IP ownership of remote electrical downtilt technology that meets AISG requirements.

65° Horizontal Beamwidth (HBW), Dual Polarization														
Model	Type	Frequency (MHz)	Beam Tilt (degrees)	Gain (dBd/dBi)	HBW (degrees)	VBW (degrees)	USLS (dB)	F/B (dB)	Isolation (dB)	VSWR	Max. Input Power (W)	Weight (kg/lb)	Length (mm/in)	Width (mm/in)
LNX-6512DS-T4M	DualPol®	698-806	4	11.9 / 14.0	65	18.0	18	30	>30	<1.35	500	12.3 / 27.1	1232 / 48.5	302 / 11.9
		806-896	4	12.4 / 14.6	65	16.0	18	30	>30	<1.35	500	12.3 / 27.1	1232 / 48.5	302 / 11.9
LNX-6512DS-T8M	DualPol®	698-806	8	11.7 / 13.8	65	18.8	18	30	>30	<1.35	500	12.3 / 27.1	1232 / 48.5	302 / 11.9
		806-896	8	12.2 / 14.3	65	16.6	18	30	>30	<1.35	500	12.3 / 27.1	1232 / 48.5	302 / 11.9
LNX-6512DS-VTM	DualPol®	698-806	0-15	11.9 / 14.0	65	19.0	17	30	>30	<1.4:1	400	12.6 / 27.7	1219 / 48.5	302 / 11.9
		806-896	0-15	12.1 / 14.3	65	17.0	17	30	>30	<1.4:1	400	12.6 / 27.7	1219 / 48.5	302 / 11.9
LNX-6513DS-T4M	DualPol®	698-806	4	12.4 / 14.5	65	16.5	18	30	>30	<1.35	400	13.6 / 30.0	1389 / 54.7	302 / 11.9
		806-896	4	12.9 / 15.0	65	14.5	18	30	>30	<1.35	400	13.6 / 30.0	1389 / 54.7	302 / 11.9
LNX-6513DS-VTM	DualPol®	698-806	0-10	12.4 / 14.5	65	16.5	17	30	>30	<1.4:1	400	13.8 / 30.5	1389 / 54.7	302 / 11.9
		806-896	0-10	12.9 / 15.0	65	14.5	17	30	>30	<1.4:1	400	13.8 / 30.5	1389 / 54.7	302 / 11.9
LNX-6514DS-T4M	DualPol®	698-806	4	13.7 / 15.8	65	12.0	18	30	>30	<1.35	500	17.0 / 37.4	1847 / 72.7	302 / 11.9
		806-896	4	14.2 / 16.3	65	12.0	18	30	>30	<1.35	500	17.0 / 37.4	1847 / 72.7	302 / 11.9
LNX-6514DS-T6M	DualPol®	698-806	6	13.7 / 15.8	65	12.0	18	30	>30	<1.35	500	17.0 / 37.4	1847 / 72.7	302 / 11.9
		806-896	6	14.2 / 16.3	65	12.0	18	30	>30	<1.35	500	17.0 / 37.4	1847 / 72.7	302 / 11.9
LNX-6514DS-VTM	DualPol®	698-806	0-12	13.7 / 15.8	65	12.0	17	30	>30	<1.4:1	400	17.1 / 37.8	1847 / 72.7	302 / 11.9
		806-896	0-12	14.2 / 16.3	65	12.0	17	30	>30	<1.4:1	400	17.1 / 37.8	1847 / 72.7	302 / 11.9
LNX-6515DS-T4M	DualPol®	698-806	4	14.9 / 17.0	65	9.0	18	30	>30	<1.35	500	23.0 / 50.8	2446 / 96.3	302 / 11.9
		806-896	4	15.4 / 17.5	65	9.0	18	30	>30	<1.35	500	23.0 / 50.8	2446 / 96.3	302 / 11.9
LNX-6515DS-VTM	DualPol®	698-806	0-8	14.9 / 17.0	65	9.0	17	30	>30	<1.4:1	400	23.3 / 51.3	2446 / 96.3	302 / 11.9
		806-896	0-8	15.4 / 17.5	65	9.0	17	30	>30	<1.4:1	400	23.3 / 51.3	2446 / 96.3	302 / 11.9
DBXNH-6565A-VTM	DualPol® dual band	698-896	0-15	11.6 / 13.7	65	16.0	17	30	>30	<1.5:1	400	15.0 / 33.1	1227 / 48.3	302 / 11.9
		1710-2180	0-8	14.0 / 16.1	65	6.8	17	30	>30	<1.5:1	300	15.0 / 33.1	1227 / 48.3	302 / 11.9
DBXNH-6565B-VTM	DualPol® dual band	698-896	0-10	12.2 / 14.3	65	12.0	17	30	>30	<1.5:1	400	20.0 / 44.0	1829 / 72.0	302 / 11.9
		1710-2180	0-6	15.7 / 17.8	65	4.5	17	30	>30	<1.5:1	300	20.0 / 44.0	1829 / 72.0	302 / 11.9
DBXNH-6565C-VTM	DualPol® dual band	698-896	0-8	13.6 / 15.7	65	8.0	17	30	>30	<1.5:1	400	25.9 / 57.0	2438 / 96.0	302 / 11.9
		1710-2180	0-6	16.0 / 18.1	65	4.5	17	30	>30	<1.5:1	300	25.9 / 57.0	2438 / 96.0	302 / 11.9

80-95° Horizontal Beamwidth (HBW), Dual Polarization														
Model	Type	Frequency (MHz)	Tilt (degrees)	Gain (dBd/dBi)	HBW (degrees)	VBW (degrees)	USLS (dB)	F/B (dB)	Isolation (dB)	VSWR	Max. Input Power (W)	Weight (kg/lb)	Length (mm/in)	Width (mm/in)
LNX-8511DS-T4M	DualPol®	698-806	4	11.0 / 13.1	85	17.0	18	30	>30	<1.35	500	11.6 / 25.5	1219 / 48.0	211 / 8.3
		806-896	4	11.5 / 13.6	85	15.5	18	30	>30	<1.35	500	11.6 / 25.5	1219 / 48.0	211 / 8.3
LNX-8511DS-VTM	DualPol®	698-806	0-15	11.0 / 13.1	85	17.0	17	30	>30	<1.4:1	400	11.8 / 26.0	1219 / 48.0	211 / 8.3
		806-896	0-15	11.5 / 13.6	85	15.5	17	30	>30	<1.4:1	400	11.8 / 26.0	1219 / 48.0	211 / 8.3
LNX-8513DS-T4M	DualPol®	698-806	4	12.8 / 14.9	85	11.0	18	30	>30	<1.35	500	11.7 / 25.8	1829 / 72.0	211 / 8.3
		806-896	4	13.3 / 15.4	85	11.0	18	30	>30	<1.35	500	11.7 / 25.8	1829 / 72.0	211 / 8.3
LNX-8513DS-VTM	DualPol®	698-806	0-10	12.8 / 14.9	85	11.0	17	30	>30	<1.4:1	400	11.9 / 26.3	1829 / 72.0	211 / 8.3
		806-896	0-10	13.3 / 15.4	85	11.0	17	30	>30	<1.4:1	400	11.9 / 26.3	1829 / 72.0	211 / 8.3
LNX-8514DS-T4M	DualPol®	698-806	4	13.8 / 15.9	85	8.0	18	30	>30	<1.35	500	18.0 / 39.7	2438 / 96.0	211 / 8.3
		806-896	4	14.3 / 16.4	85	8.0	18	30	>30	<1.35	500	18.0 / 39.7	2438 / 96.0	211 / 8.3
LNX-8514DS-VTM	DualPol®	698-806	0-8	13.8 / 15.9	85	8.0	17	30	>30	<1.4:1	400	18.0 / 39.7	2438 / 96.0	211 / 8.3
		806-896	0-8	14.3 / 16.4	85	8.0	17	30	>30	<1.4:1	400	18.0 / 39.7	2438 / 96.0	211 / 8.3
DBXNH-8585A-VTM	DualPol® dual band	698-896	0-15	11.1 / 13.2	85	16.0	17	30	>30	<1.4:1	400	14.0 / 30.9	1227 / 48.3	302 / 11.9
		1710-2180	0-10	14.4 / 16.5	85	7.2	17	30	>30	<1.4:1	300	14.0 / 30.9	1227 / 48.3	302 / 11.9
DBXNH-8585B-VTM	DualPol® dual band	698-896	0-10	12.4 / 14.5	85	11.5	17	30	>30	<1.5:1	400	19.1 / 42.0	1852 / 72.9	302 / 11.9
		1710-2180	0-6	15.4 / 17.5	85	4.8	17	30	>30	<1.5:1	300	19.1 / 42.0	1852 / 72.9	302 / 11.9
DBXNH-8585C-VTM	DualPol® dual band	698-896	0-8	13.8 / 15.9	85	8.0	17	30	>30	<1.4:1	400	23.1 / 51.0	2446 / 96.3	302 / 11.9
		1710-2180	0-6	15.7 / 17.8	85	4.5	17	30	>30	<1.4:1	300	23.1 / 51.0	2446 / 96.3	302 / 11.9

80-95° Horizontal Beamwidth (HBW), Vertical Polarization														
Model	Type	Frequency (MHz)	Tilt (degrees)	Gain (dBd/dBi)	HBW (degrees)	VBW (degrees)	USLS (dB)	F/B (dB)	Isolation (dB)	VSWR	Max. Input Power (W)	Weight (kg/lb)	Length (mm/in)	Width (mm/in)
DB844H90E-A	Directed Dipole™	746-806	0	12.0 / 14.1	90	15.0	15	40	-	<1.4:1	500	4.5 / 10.0	1219 / 48.0	152 / 6.0

>105° Horizontal Beamwidth (HBW), Vertical Polarization														
Model	Type	Frequency (MHz)	Tilt (degrees)	Gain (dBd/dBi)	HBW (degrees)	VBW (degrees)	USLS (dB)	F/B (dB)	Isolation (dB)	VSWR	Max. Input Power (W)	Weight (kg/lb)	Length (mm/in)	Width (mm/in)
DB878H120E-A	Sector	746-806	0	14.0 / 16.1	120	7.0	-	22	-	<1.5:1	500	11.3 / 25.0	2438 / 96.0	318 / 12.5

360° Horizontal Beamwidth (HBW), Vertical Polarization														
Model	Type	Frequency (MHz)	Tilt (degrees)	Gain (dBd/dBi)	HBW (degrees)	VBW (degrees)	USLS (dB)	F/B (dB)	Isolation (dB)	VSWR	Max. Input Power (W)	Weight (kg/lb)	Length (mm/in)	Radome OD (mm/in)
DB806-A	Omni	740-806	0	6.0 / 8.1	360	16.0	-	-	-	<1.5:1	400	7.3 / 16.0	1575 / 62.0	50.8 / 2.0
DB589-A	Omni	746-806	0	9.0 / 11.1	360	7.5	-	-	-	<1.5:1	500	5.2 / 11.5	4211 / 165.8	50.8 / 2.0
DB810EPS	Omni	746-869	0	10.0 / 12.1	360	6.0	-	-	-	<1.5:1	500	17.2 / 38.0	4496 / 177.0	76.2 / 3.0
DB810KE-A	Omni	746-776	0	10.0 / 12.1	360	6.0	-	-	-	<1.5:1	500	18.1 / 40.0	4846 / 190.8	76.2 / 3.0

Andrew Tower Mounted Amplifier

Tower Mounted Amplifier products are now available in our industry-leading 4th generation OneBase® platform, which includes the following features and benefits:

- Smaller, lighter form factor reduces tower loading and leasing costs.
- Cost-efficient twin and dual-band configurations reduce CAPEX.
- AISG capability enables integration and control of tower-top components.
- VSWR monitoring of the antenna port connections minimizes downtime.
- Intelligent DC power and AISG switching supports power/AISG redundancy and provides enhanced versatility and interoperability.
- Backward compatibility with 2G BTS equipment.



E15Z01P07
OneBase®
Dual Duplex TMA

Expected Performance: 700 MHz and AWS TMA

Electrical	700 MHz	AWS
UPLINK		
Frequency range, MHz	698-716	1710-1755
Gain, dB	12 ± 1	12 ± 1
Total group delay, ns	200 max	50 max
Group delay variation, ns	100 max	15 max
Noise figure, dB	2.0 max	1.6 max
Return loss, dB	18 min	18 min
Output IP3, dBm	+20	+20
DOWNLINK		
Frequency range, MHz	700-746	2110-2155
Insertion loss, dB	0.5 max	0.3 max
Total group delay, ns	100 max	15 max
Group delay variation, ns	85 max	10 max
Return loss, dB	18 min	18 min
Maximum input power – RMS, W	200	
Maximum input power – PEP, W	3000	
Passive IM products [2 x 43 dBm], dBc	153 typical	
Insertion loss 850 pass-through	(869-894 MHz), dB	0.3 max
Insertion loss PCS pass-through	(1930-1990 MHz), dB	0.3 max

AISG	
Protocol	AISG 2.0 standard
RET antenna support	24 Vdc & RS-485

POWER	
Power supply voltage, Vdc	7-30

Mechanical	
Height, depth, width, mm (in)	250 x 290 x 75 (9.8 x 11.4 x 3.0)
Weight w/o mounting hardware, kg (lb)	7.7 (17.0)
Finish	Gray paint
Connectors, RF	7-16 DIN-F (long-neck)
Connector, AISG	8 pin circ, IEC60130
Ground screw diameter, in	1/4 in

Environmental	
Operating temperature range, °C	-40 to +65
Relative humidity, %	5-100
Ingress protection	IP67
Lightning protection ANT port	dc ground
Lightning protection BTS port	10 kA, 8/20 us

700 MHz / AWS Dual Band TMA

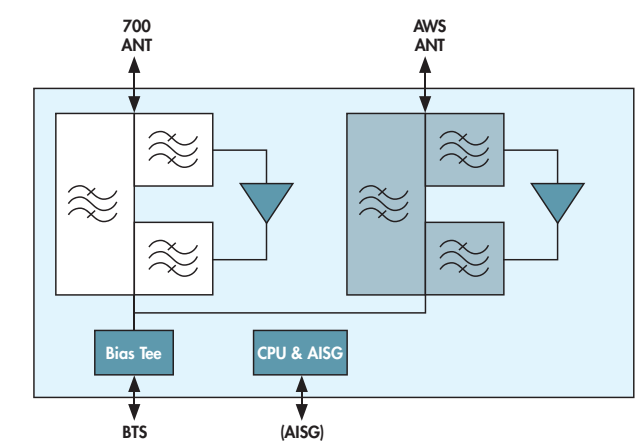

Andrew's Crossband Coupler Products 700 MHz and Multi-Band

Andrew Crossband Coupler (CBC) products are available in a wide variety of frequency band combinations, both as wideband diplexers, and in the form of diplexers and triplexers for specific bands. Our CBC product portfolio offers the following features and benefits:

- Compact form factors reduce tower loading and leasing costs.
- Stackable designs and available multi-unit mounting kits simplify installation.
- Optional internal or external dc blocking accommodates different site architectures.
- Compatibility with AISG signaling on the RF path.
- Superior power ratings support multi-carrier applications with all modulations.
- Rugged design using proven 850 MHz technology.
- Superior RF performance.
- Outstanding field record – hundreds of thousands of units deployed worldwide.
- Ideal choice for both suburban and rural areas.

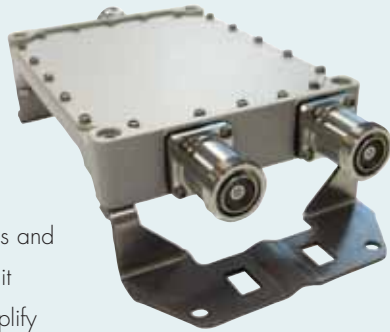

Crossband Coupler for 700/800 MHz and PCS/AWS

Model: CBC7021			
Electrical	Low Frequency Path	High Frequency Path	
Frequency range, MHz	698–894	1710–2155	
Insertion loss, dB	0.2 max	0.35 max	
Total group delay, ns	10 max	10 max	
Isolation at high frequency band, dB	50 min	50 min	
Return loss, dB	18 min	18 min	

Mechanical	
Height, depth, width, mm (in)	200 x 150 x 35 (7.9 x 5.9 x 1.4)
Weight w/o mounting hardware, kg (lb)	1.8 (4.0)
Finish	Gray paint
Connectors, RF	7–16 DIN-f (long-neck)
Connector, AISG	8 pin circ, IEC60130
Ground screw diameter, in	1/4

Crossband Coupler for 700 MHz and 850 MHz

Model: CBC7085			
Electrical	Low Frequency Path	High Frequency Path	
Frequency range, MHz	698–787	824–894	
Insertion loss, dB	0.3 max	0.3 max	
Total group delay, ns	30 max	25 max	
Isolation at high frequency band, dB	50 min	50 min	
Return loss, dB	20 min	20 min	

Mechanical	
Height, depth, width, mm (in)	200 x 150 x 65 (7.9 x 5.9 x 2.6)
Weight w/o mounting hardware, kg (lb)	2.3 (5.1)
Finish	Gray paint
Connectors, RF	7–16 DIN-f (long-neck)
Ground screw diameter, in	1/4

Triplexer for 700 MHz and 850 MHz and PCS/AWS

Model: CBC7821				
Electrical	Low Frequency Path	MID Frequency Path	High Frequency Path	
Frequency range, MHz	698–787	824–894	1710–2155	
Insertion loss, dB	0.25 max	0.25 max	0.25 max	
Total group delay, ns	30 max	25 max	10 max	
Isolation at high frequency band, dB	50 min	50 min	50 min	
Return loss, dB	20 min	20 min	20 min	

Mechanical	
Height, depth, width, mm (in)	200 x 190 x 65 (7.9 x 7.5 x 2.6)
Weight w/o mounting hardware, kg (lb)	2.5 (5.5)
Finish	Gray paint
Connectors, RF	7–16 DIN-f (long-neck)
Ground screw diameter, in	1/4

General Environmental for CBC7021 and CBC7085 Crossband Couplers and CBC7821 Triplexer

Operating temperature range, °C	–40 to +65
Relative humidity, %	5–100
Ingress protection	IP67
Lightning protection ANT port	dc ground
Lightning protection BTS port	10 kA, 8/20 µs



www.commscope.com/andrew

Visit our Web site or contact your local Andrew representative for more information.

© 2009 CommScope, Inc. All rights reserved.

Andrew is a trademark of CommScope. All trademarks identified by ® or ™ are registered trademarks or trademarks, respectively, of CommScope. This document is for planning purposes only and is not intended to modify or supplement any specifications or warranties relating to Andrew products or services.

BR-103009EN (02/09)