

**NEW PRODUCT
ANNOUNCEMENT**



ValuLine® III Next Generation Antennas VHLPX4

SPECIFICATIONS

	VHLPX4-6W	VHLPX4-7W	VHLPX4-10W	VHLPX4-11	VHLPX4-13	VHLPX4-15	VHLPX4-18	VHLPX4-23	VHLPX4-26
Frequency Band, GHz	5.925-7.125	7.125-8.5	10.0-10.7	10.7-11.7	12.7-13.25	14.25-15.35	17.7-19.7	21.2-23.6	24.25-26.5
Bottom Band Gain, dBi	34.0	36.8	39.6	40.0	41.9	42.7	44.2	45.9	47.0
Mid Band Gain, dBi	35.0	37.3	40.0	40.4	42.0	42.9	44.7	46.7	47.4
Top Band Gain, dBi	36.0	37.7	40.4	40.8	42.1	43.1	45.1	46.9	47.8
Beamwidth, degrees	2.9	2.2	1.6	1.5	1.3	1.2	0.9	0.8	0.6
Front/Back, dB	61	63	66	67	68	71	72	74	75
XPD, dB	32	32	30	30	30	30	30	30	30
Return Loss, dB	17.7	17.7	17.7	17.7	17.7	17.7	17.7	17.7	17.7
Regulatory Compliance									
ETSI Class	R1 C3	R1 C3	R1 C3	R1 C3	R1 C3	R2 C3	R2 C3	R3 C3	R4 C3
FCC Part 101	N/A	N/A	Cat A	Cat A	Cat B	N/A	Cat A	Cat A	Cat A
Brazil Anatel	N/A	C2	C2	C2	C2	C2	C2	C2	C2
Canada SRSP	N/A	N/A	310.5	N/A	312.7B	314.5A	317.8A	321.8A	N/A
Andrew RPE Number	7137	7080A	7097	7044A	7050	7056	7062	7068	7074

VHLPX4-7W SUB-BAND PERFORMANCE

Band	7.125-7.75	7.425-7.9	7.75-8.5
Bottom Band Gain, dBi	36.8	37.0	37.3
Mid Band Gain, dBi	37.0	37.2	37.5
Top Band Gain, dBi	37.3	37.3	37.7

SPECIFICATIONS

ValuLine® III Next Generation Antenna—VHLPX4

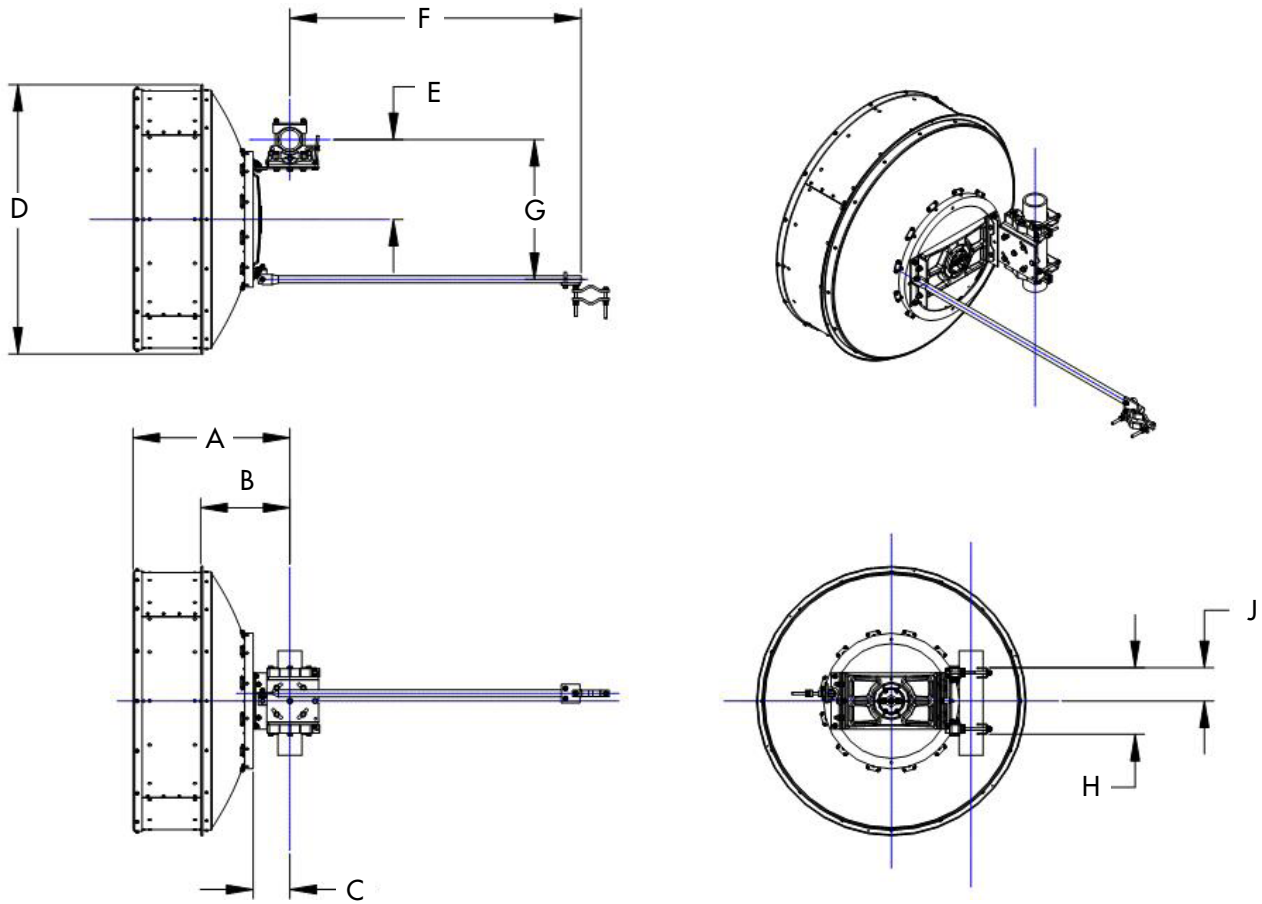

Antenna Dimensions, mm (in)

A	751 (29.5)
B	427 (16.8)
C	176 (6.9)
D	1291 (50.8)
E	382 (15)
F	1395 (54.9)
G	670 (26.4)
H	320 (12.6)
J	160 (6.3)

Antenna Fine Adjustment

Fine Azimuth	$\pm 12^\circ$
Fine Elevation	$\pm 15^\circ$

ValuLine® III Next Generation Antenna—VHLPX4

Wind Loading

The axial, side, and twisting moment forces stated below are the maximum loads applied to the tower by the antenna at a survival windspeed of 250 km/h (155 mph). They are the result of wind from the most critical direction for each parameter. The individual maximums may not occur simultaneously. All forces are referenced to the antenna mounting pipe.

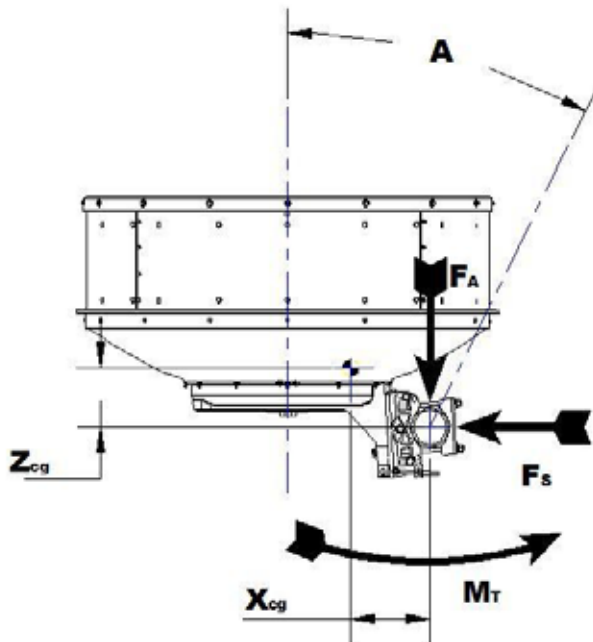

Axial force	F_A	4394 N (988 lbf)
Side force	F_S	2176 N (489 lbf)
Moment	M_T	1749 N-m
Angle A for M_T maximum		-130°

Where side struts are fitted, the loads carried by the side struts are components of, not in addition to F_A , F_S , and M_T .

Z_{CG}^* Without Ice, mm (in)	170.6 (6.7)
X_{CG} Without Ice, mm (in)	242.7 (9.5)

* Z_{CG} is the axial distance from the center of gravity to the mounting pipe.

Antenna Weights Including Mount

Antenna Without Ice, kg (lb)	46 (101.4)
Antenna with 25 mm (1 in) Radial Ice, kg (lb)	115 (253.5)

Antenna Packed Weights (Gross)

Weight, kg (lb)	102 (224.9)
-----------------	--------------------

Packed Antenna Dimensions (Single Unit Pack)

Dimensions, cm (in)	137 x 137 x 82 (54 x 54 x 323)
---------------------	---------------------------------------



www.andrew.com

Visit our Web site or contact your local Andrew Wireless Solutions representative for more information.

© 2008 CommScope, Inc. All rights reserved.

Andrew Wireless Solutions is a trademark of CommScope. All trademarks identified by ® or ™ are registered trademarks or trademarks, respectively, of CommScope. This document is for planning purposes only and is not intended to modify or supplement any specifications or warranties relating to Andrew Wireless Solutions products or services.

PA-101690.2-EN (3/08)