

PRODUCT
SPECIFICATION



OneBase™ Crossband Coupler

Outdoor diplexer combines 806–940 MHz & 1850–2000 MHz

Extremely low insertion loss and high power handling capability.

The Andrew Crossband Coupler combines signals from wireless systems operating in the 806–940 MHz bands with signals in the 1850–2000 MHz bands onto a common feeder cable.

These couplers use novel suspended stripline printed circuit board technology to provide extremely low insertion loss, high isolation, and high power handling capability in a compact, rugged, weather-proof housing. Sealing gaskets provide protection from moisture ingress at all interfaces.

These couplers feature long neck precision 7-16 DIN female connectors for ease of weatherproofing and an external grounding stud for lightning protection.

- Novel stripline printed circuit board
- Extremely low insertion loss
- Moisture protection
- Stackable
- Mounting bracket and external grounding stud provided
- Integrated dc block/bypass versions available

OneBase™ Crossband Coupler

Electrical

Low path frequency band, MHz	806–940
High path frequency band, MHz	1850–2000
Low path insertion loss, dB	0.2 maximum
High path insertion loss, dB	0.2 maximum
Return loss—all ports, dB	20 minimum
Isolation—between paths, dB	50 minimum
Maximum power, simultaneous operation	
low path, watts	500
high path, watts	275
dc Breakdown—center conductor to ground, V	4000
Lightning protection—center conductor	15 kA, 8/20 μ s
Lightning protection—outer conductor	50 kA, 8/20 μ s

Environmental

Operating temperature range, °C	-40 to +65
Moisture resistance	IP68
Vibration (10–2000 Hz, sinusoidal: 3 planes)	IEC 68-2-6
Mechanical shock	IEC 689-2-27, 50g
Salt fog	IEC 68-2-11 (336 hrs.)
Solar radiation	IEC 68-2-5
Thermal shock	IEC 68-2-14
Humidity	IEC 68-2-30

Mechanical

Dimensions, mm (in)	186 x 186 x 50 (7.32 x 7.32 x 0.97)
Weight, kg (lb)	1.95 (4.3)
Finish	Gray paint
Connectors—long neck	7-16 DIN female
Ground lug diameter, mm (in)	8 (5/16)

Dimensions—CBC819 Series Crossband Coupler, mm [in]

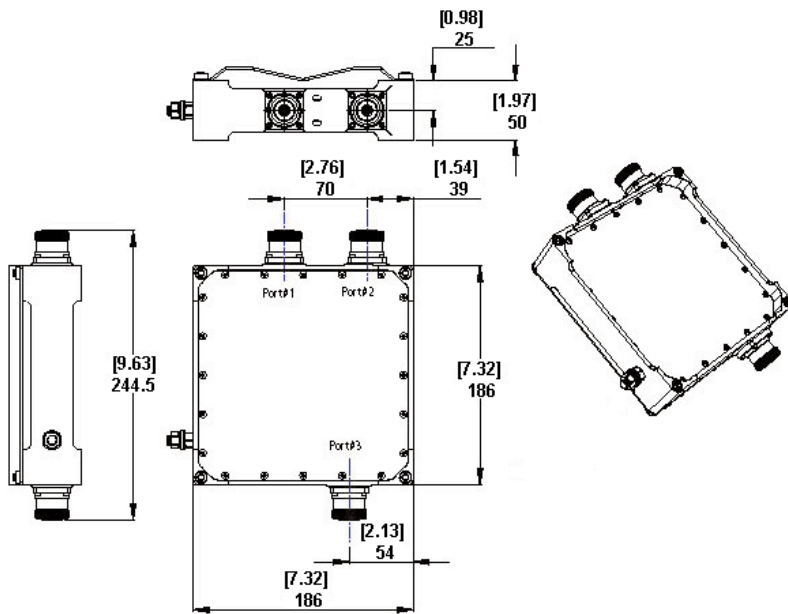

Ordering Information

Part Number	Description
CBC819-DF	Crossband Coupler, dc pass on all paths
CBC819-DF-9-DCB	Crossband Coupler, dc pass on PCS1900 path
CBC819-DF-19-DCB	Crossband Coupler, dc pass on 850/900 path



One Company. A World of Solutions.

Andrew Corporation
3 Westbrook Corporate Center
Suite 900
Westchester, IL 60154 US

Customer Support Center
From North America
Telephone: 1-800-255-1479
Fax: 1-800-349-5444

International
Telephone: +1-708-236-6600
Fax: +1-708-492-3898

Internet: www.andrew.com

All designs, specifications, and availabilities of products and services presented in this bulletin are subject to change without notice.

Bulletin PA-101240-EN (6/06)

© 2006 Andrew Corporation, Westchester, IL 60154 US