

Laying the groundwork for a new level of Power over Ethernet

April 2017

Contents

Laying the groundwork for a new level of Power over Ethernet	3
PoE basics	3
PoE standards development	4
Four-pair PoE: A closer look	6
Network and channel design	6
Termination points beyond the desk	7
Universal Connectivity Grid	8
Thermal loading	8
Cabling and connectors must be up to the task	9
IEEE 802.3bt progress	11
Recommendations	11
Rely on CommScope to keep you updated	11
Bibliography	12
References	12

Laying the groundwork for a new level of Power over Ethernet

Enterprise networks continue to expand, growing more versatile and complex. Devices once considered peripherals—wireless access points (WAPs), security network cameras, building automation and control systems, and voice-over-IP (VoIP) phones—are now important network assets. As more devices are added, the cabling infrastructure needed to support them grows, and the option to power them over structured cabling becomes more attractive.

Over the past decade, Power over Ethernet (PoE) has emerged as a key powering strategy, allowing network managers, installers, and integrators to use structured cabling to provide both power and data to many of their network devices. The original PoE standard—IEEE 802.3af, adopted by the IEEE PoE Task Force in 2003—limited the technology to devices requiring less than 12.95 watts of power. Less than three years after the first standard was published, growing demand for PoE applications beyond 12.95 watts led to efforts to update it.

The revised PoE standard, IEEE 802.3at—also known as PoE Plus or PoE+—was adopted in 2009 and raised the PoE power supply to 25.5 watts. Since then, the industry's interest in, and demand for, higher power PoE solutions has continued to snowball. The IEEE PoE Task Force is already well into the development of the next evolution of the standard. The new standard, IEEE P802.3bt, is intended to deliver at least 71.3 watts of power to PoE-enabled devices, assuming a 100-meter channel. As can be expected, device and power supply manufacturers are well ahead of the curve, already providing nonstandardized equipment. The evolution of remote powering is illustrated in Figure 1.

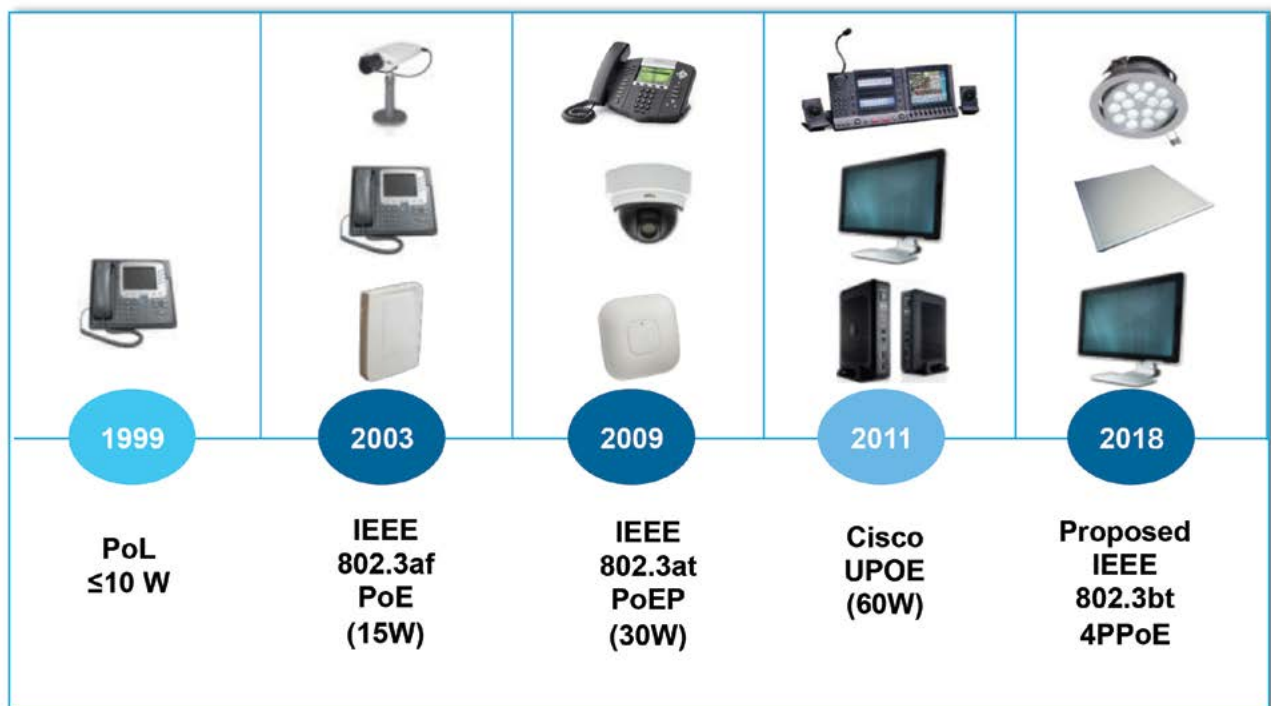

Figure 1: The evolution of remote powering technology

CommScope has made significant contributions to the standardization efforts in IEEE as well as in the relevant cabling standard groups in TIA, ISO/IEC and CENELEC. In characterizing our cabling systems' performance with increasing current levels, we have done comprehensive testing and modeling and have shared this work with the standards groups above.

This white paper provides a brief overview of the PoE technology, the status of standardization efforts, and key guidelines and recommendations intended to ensure that the cabling infrastructure is capable of supporting the PoE evolution.

PoE basics

PoE describes a system to safely transmit electrical power—along with data—to remote devices over standard Category 3 and higher Category cabling. PoE is designed so Ethernet data and power signals do not interfere with each other, thereby enabling simultaneous transmission without signal disruption.

PoE works by converting the mains power supply into a low-voltage supply, then transmitting the power over structured cabling to PoE-enabled devices. Some power dissipation is inevitable. For example, systems meeting the PoE 802.3af-2003 standard introduce 15.4 watts of power on the cabling, but only 12.95 watts can be expected to be received by the powered device.

The PoE system consists of the power sourcing equipment (PSE), which supplies the power, and the powered device (PD), which receives the power. PSEs are typically designed as end-span or mid-span power supplies. The end-span PSE is typically built into an Ethernet switch port, with an estimated 100 million PoE-enabled ports shipping annually¹. As the name suggests, the end-span PSE, illustrated in Figure 2, resides at the LAN endpoint opposite the PD.

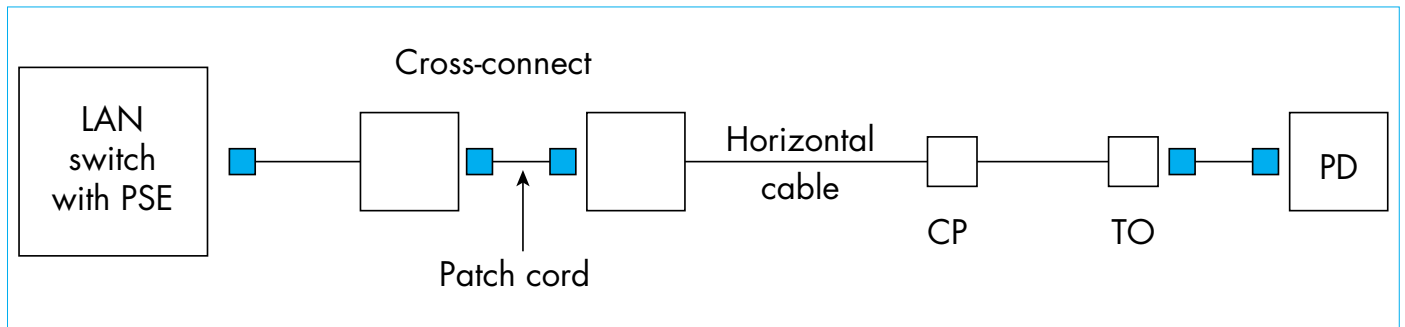

Figure 2: Power supplied from LAN equipment with end-span PSE

A mid-span PSE, located between the Ethernet switch and the PD, injects power that is fed to the PD without disrupting the data signals. For this reason, mid-spans are commonly referred to as PoE injectors. A mid-span PSE can be used as a standalone power source, as shown in Figure 3.

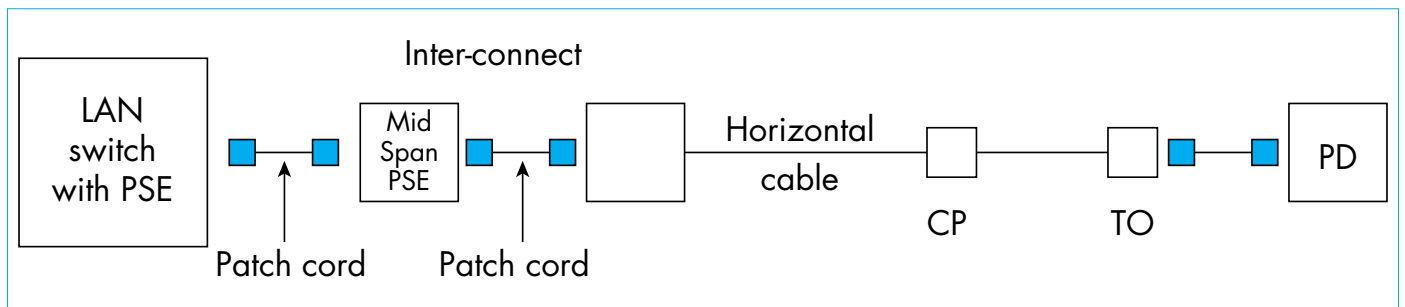

Figure 3: Power supplied from mid-span PSE

The PDs are at the receiving end of the PoE distribution system and operate on low-voltage direct current (dc). Many PDs also feature an integrated PoE splitter, which separates the power and data signals for redistribution to other devices.

When used in VoIP, wireless LAN and IP security applications, a PoE system can save up to 50 percent of the overall installation costs by eliminating the need to install separate electrical wiring and power outlets². With the uninterruptable power supply (UPS) integrated into most LANs, PoE systems using end-span PSEs also provide continuous operation in case of a power failure.

PoE standards development

Parameter	PoE (802.3af)	PoE Plus (802.3at)	4-pair PoE (802.3bt)
PSE Power (W)	15.4	30	90
PD Power (W) (assuming 100-meter channel)	12.95	25.5	71.3
Current (mA _{dc})	350	600	1920
Pairs used	2-pr	2-pr	4-pr
DC loop resistance per conductor (Ω /100-meter)	40	25	25
Year standardized	2003	2009	2018 (est)

Figure 4: Comparison of existing and proposed PoE standards

The original IEEE 802.3af-2003 standard, adopted in 2003, provides up to 15.4 watts of dc power at the PSE and uses two of the four twisted pairs in the structured cabling. Because some power is dissipated in the cabling, only 12.95 watts are assured to be available at the PD. This amount is enough to power a wide variety of network devices, including VoIP phones, simple networked security cameras, WAPs, digital clocks, as well as building and access control devices. The IEEE standard for PoE Plus—IEEE 802.3at, ratified in 2009—permits the PSE to supply up to 30 watts of dc average power and the PDs to receive up to 25.5 watts of dc average power over two pairs.

The breadth of existing devices utilizing PoE has driven suppliers to demand more from the underlying infrastructure so that other PoE devices can be created. The new infrastructure must deliver more power while increasing efficiency. With some devices, such as IEEE 802.11ac WAPs, expected to exceed gigabit Ethernet capabilities, the standards will also need to adapt to allow for PoE on higher bandwidth links, such as 2.5GBASE-T, 5GBASE-T and 10GBASE-T.

Industry	Application	Typical power consumption
Healthcare	Nurse call systems	50 W
Retail	Point-of-sale devices	30-60 W
Banking/financial	IP turrets	45 W
Building management	Variable air volume controllers, access controllers	40-50 W
Enterprise IT	Thin clients, virtual desktop terminals	50 W
Enterprise IT	Multichannel wireless APs	>30 W
Enterprise	Digital signage	>30 W ≥85 W
Hospitality	PoE switches	45-60 W
Premises security	Pan, tilt and zoom cameras	30-60 W
Industrial	Industrial brushless drives, motor control	>30 W
Enterprise	LED lighting	6-60 W

Figure 5: New and emerging PoE applications

As is often the case, market requirements move faster than standards can be created. In 2009, a new generation of PoE-enabled devices, requiring power beyond the 25.5-watt limits of PoE Plus, is available. Figure 5 lists some of the industries and applications that could immediately benefit from higher-power PoE standards. In response to the demand, an IEEE 802.3 study group was formed to consider standardizing PoE over all four pairs in balanced twisted-pair cabling and was subsequently approved as a task force.

The new IEEE 802.3bt Task Force is charged with creating a four-pair PoE standard that will supply at least 71.3 watts to a powered device while improving the efficiency of power delivery. The new standard will include a pair-to-pair resistance unbalance specification of approximately 7 percent, which should allow the use of most of the installed base of Category 5e and better cabling.

The standard will merge the existing solutions from several manufacturers (which today may or may not follow) into a standards-based implementation. These manufacturers are already offering solutions with higher capacity power to support emerging applications that need extra power today. Examples include Cisco's Universal PoE (UPoE), which extends the IEEE 802.3 PoE+ standard to 60 watts per port.

Four-pair PoE: A closer look

The new IEEE 802.3bt standard will allow device manufacturers to create solutions that deliver more power while increasing efficiency and providing support for 2.5-, 5- and 10-Gigabits-per-second (Gbps) connections. Figure 6 illustrates a PoE system as depicted in the IEEE 802.3at 2009 standard. When used for PoE Plus, either Alternative A or Alternative B may be used to deliver power over two pairs of wires. The IEEE 802.3bt standard, however, will enable the simultaneous use of both Alternative A and Alternative B, essentially doubling the amount of available power. Four-pair PoE also reduces the amount of power dissipated along the cabling, enabling network operators to curb power losses by as much as 50 percent compared to two-pair PoE solutions, regardless of the type of cabling used.³

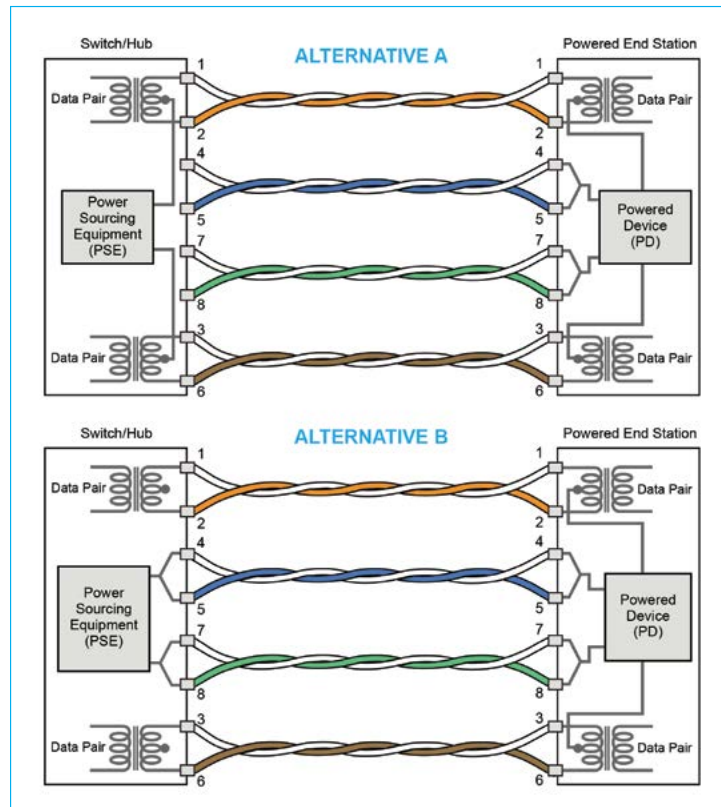

Figure 6: Alternative A and Alternative B designs for use with end-span PSE, according to IEEE 802.3at-2009

In determining whether a four-pair PoE network makes sense for a given installation, network managers should consider a wide number of variables. These include the overall network and channel requirements, effects on thermal and capacity limitations, and cabling and deployment strategies.

Network and channel design

The network and channel design considerations for four-pair PoE will be the same as existing design considerations for PoE and PoE+. With regard to channel topology, the four-pair PoE standard addresses power distribution to PDs via existing cabling types that have up to four twisted pairs and are up to 100 meters in length. For detailed information regarding the various topologies for supporting four-pair PoE, refer to ISO/IEC 11801 Generic Cabling for Customer Premises, ANSI/TIA-568-C.2 Balanced Twisted-pair Telecommunications Cabling and Component Standard, and the CENELEC EN 50173 series of Information Technology Generic Cabling Systems.

According to the current scope of the four-pair PoE discussion, all cabling must, at minimum, meet the performance requirements for Category 5e cabling over a 100-meter channel, including a worst-case scenario of four connections.

It should be noted that Category 5e cabling only provides the minimum level of performance required. Therefore, it is recommended to use Category 6 or Category 6A cabling—preferably, solutions such as CommScope's GigaSPEED® XL or GigaSPEED X10D that have been tested for compliance to the corresponding category or Class per ANSI/TIA-568 and ISO/IEC 11801, and CENELEC EN 50173 series of standards.

The ISO/IEC 14763-2, ISO/IEC TR 29125, CENELEC TR 50174-99-1 and the TIA-TSB-184-A cabling installation standards recommend cable bundles with 24 cables or less to allow for worst case conditions regarding conductor gauge, powering and installation conditions.

Termination points beyond the desk

In a typical office environment, most cabling termination points are located in work areas and near end-user desk locations. As their ability to provide more power increases, PoE devices are not only becoming more common, they are also becoming more varied in their applications.

Today's PoE-enabled devices include motorized surveillance cameras, video phones, HD displays, and low-powered intelligent building devices like controllers, sensors, and actuators. Consider the placement of some of the following PoE applications.

- Retail outlet points of service (POS)
- Video conferencing and hospitality locations
- IP security cameras for monitoring secure areas
- Access control readers
- Building controllers and sensors
- Digital signage
- Multichannel wireless APs
- LED lighting

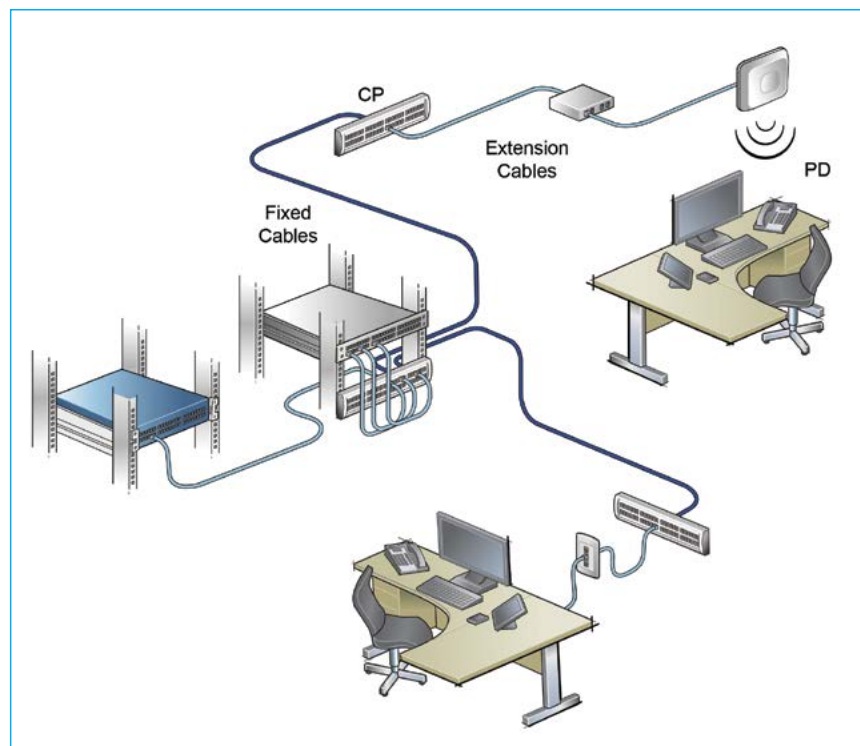

Figure 7: Zone cabling using consolidation points

These devices may or may not connect to the traditional wall-mounted, desk-side telecommunications outlet (TO). Increasingly, the connection points for these devices will be found in the ceiling, next to doors or entrances, in prominent wall locations, and outside and/or in remote corners of the building. These nonconventional outlet locations present new and different challenges, such as the need for additional cabling capacity, routing access, and special requirements for fire-rated and/or plenum-rated components. Addressing these issues requires pre-installation planning to ensure balanced twisted-pair cabling is available for all locations needing PoE.

Universal Connectivity Grid

In a traditional network cabling topology, TOs used for PoE are directly connected via horizontal cables to the patch panel in the floor's telecommunications room. For many installations involving four-pair PoE, especially new installations, a cabling approach known as the Universal Connectivity Grid⁴ (UCG) can provide easier cable routing and greater flexibility. With the UCG design concepts, the ability to easily accommodate moves, adds and changes by simply connecting the PD to a zone distributor saves labor and materials, lowering initial CapEx installation costs and ongoing OpEx.

The TIA-862-B, CENELEC EN 50173-6 and the ISO/IEC draft 11801-6 standards describe a similar design concept. They both focus on non-user-specific applications, many of which use PoE.

The UCG model, as shown in Figure 7, uses cable runs from the equipment room to specific "building zones." A consolidation point (CP) within each zone allows fixed cabling to be installed up to the CP; drop cabling then runs from the CP to the TO for each PD. This approach provides additional flexibility in cabling from the CP to the first TO in each cell, as well as providing spare capacity for additional TOs as needed.

Ideal for new installations, this strategy can also be helpful during retrofit installations, where well-placed consolidation points allow long runs of cabling bundles from the telecommunications room to be fixed into difficult pathways. Once the fixed cabling is in place, installers have more flexibility in running and changing extension cable from the CP to the TO serving the PDs for data and intelligent building equipment.

Thermal loading

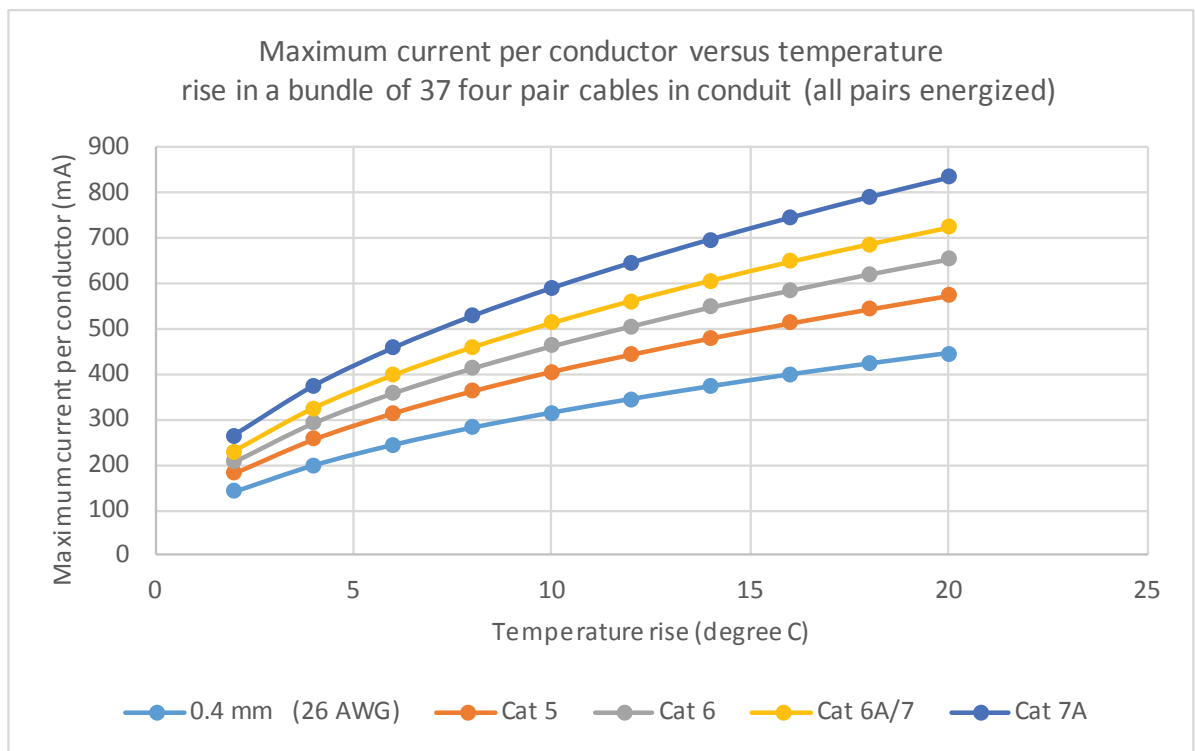

Figure 8: Effects of dc current on cable temperature

In order to minimize cooling costs and maximize the usable lifespan of the cabling infrastructure, it is important to take into account the thermal load on the cabling. When remote power is applied to balanced cabling, the temperature of the cabling will rise due to heat generation in the copper conductors. Figure 8 illustrates the worst-case relationship between current, expressed in milliamps, and the thermal load on wire pairs of varying categories within a 37-cable bundle.

The IEEE 802.3bt four-pair PoE standard is expected to assume a maximum temperature rise of 10 degrees Celsius when all four pairs are energized. For cabling with an operational temperature range of -20 degrees Celsius to 60 degrees Celsius, the ambient temperature should not exceed 50 degrees Celsius. Using a higher category cable with lower dc resistance and improved heat dissipation can help reduce the rise in temperature.

Consequently, CommScope recommends Category 6A cabling for four-pair PoE applications. Because increased thermal loading can also increase insertion loss, the maximum cable length should be de-rated for higher temperatures, per ANSI/TIA-568-C.2 Balanced Twisted-pair Telecommunications Cabling and Component Standard, or alternatively the ISO/IEC 11801 or CENELEC EN 50173 series standards.

Cabling and connectors must be up to the task

Consideration must also be given to the continuous current handling capability of the connecting hardware and outlet connector. The maximum continuous output current from the PSE under normal mode—over one pair or 480 milliamps (mA) dc per conductor—is 1920 mA dc. This represents the maximum allowable current for the expected 802.3bt standard. The connecting hardware and telecommunications outlet connector should be able to handle this current. CommScope cabling solutions meet or exceed this requirement.

Additionally, CommScope cabling systems are guaranteed to support all the implementations defined in the existing IEEE PoE standards and the proposed IEEE 802.3bt standard. Although not standardized, Cisco's UPoE implementation is also supported. IEEE 802.3 PoE and Cisco's UPoE are covered by the CommScope Extended Product Warranty and Application Assurance Program, when deployed in a certified CommScope installation that meets the relevant design and installation guidelines.

If connectors are unplugged under load, an inductive current is created within the connector that may spark at one or more contact surfaces, causing the surfaces to corrode. The applicable test standard is IEC 60512-99-001. The present standard calls for 600 mA to be applied to each contact in accordance to IEEE 802.3at PoEP requirement and is easy to pass. CommScope has carried out extensive testing on its connectors and connecting hardware using current level beyond the present standard. This is shown in Figure 9.

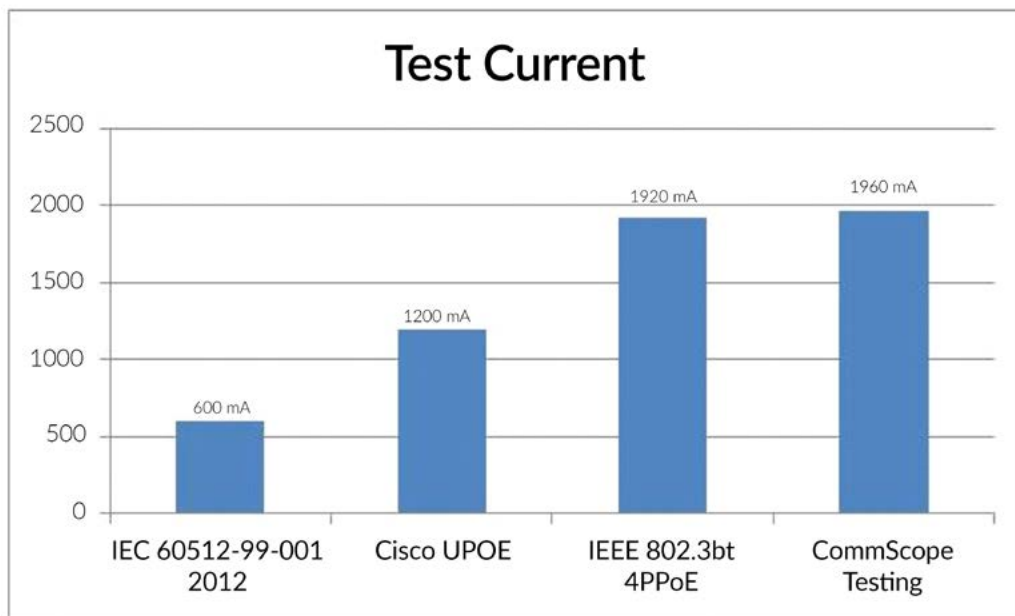

Figure 9: CommScope connector/connecting hardware test current level comparison

Figure 10 shows an example of the arcing and contact areas for CommScope MGS600 connector with an applied current of 1960 mA. Based on CommScope's lead-frame design shown in Figure 11, the arcing area is far away from the contact area and the arcing will not affect the critical contact area. Hence, CommScope outlets can reliably support the IEEE 802.3bt 4PPoE applications.

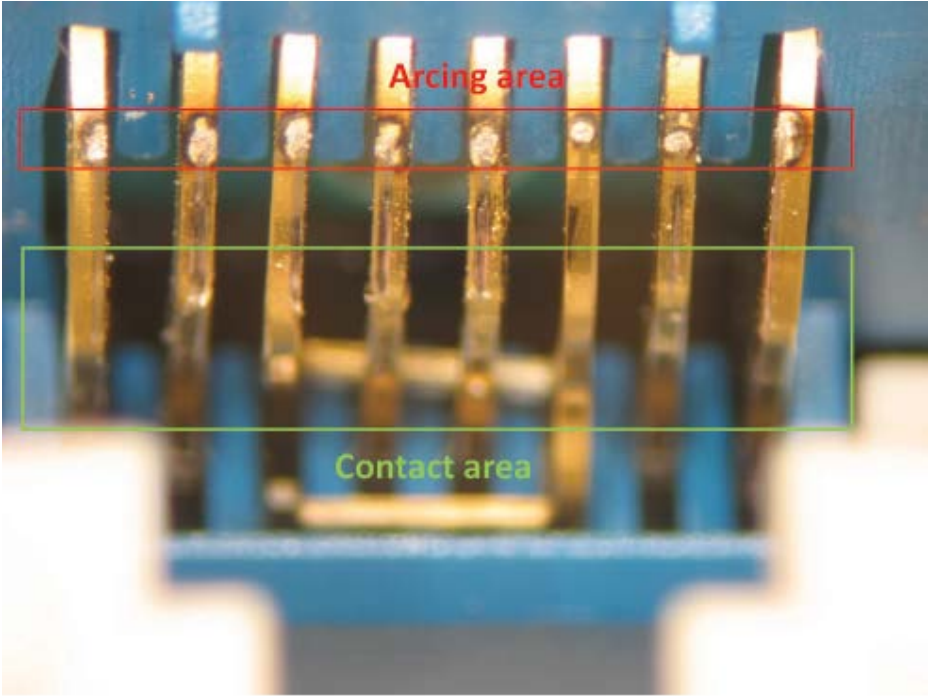

Figure 10: Arcing and contact areas for CommScope MGS600 connector (Applied current = 1960 mA).

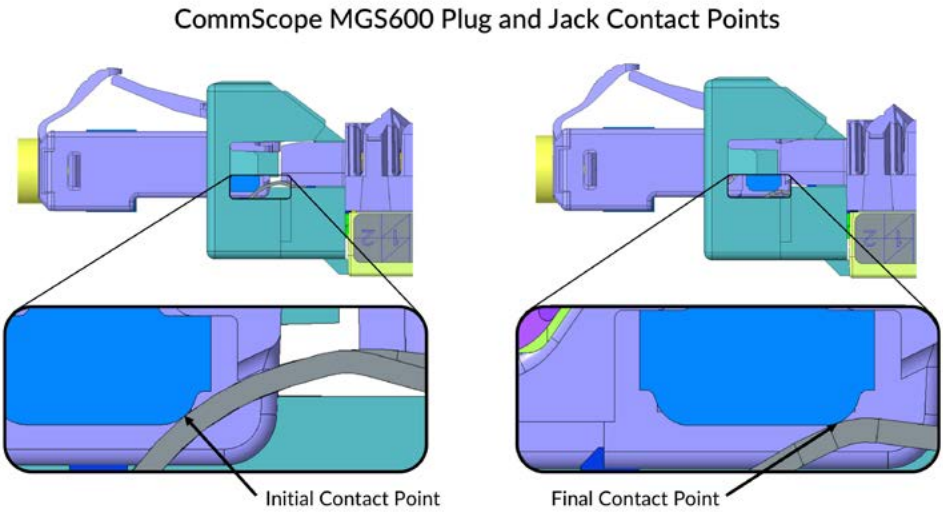

Figure 11: CommScope lead-frame design showing contact points between plug and jack

IEEE 802.3bt progress

Following a call for interest, the IEEE 802.3bt study group was approved and convened in May 2013. One of the first tasks was to develop overall objectives for consideration by the parent IEEE 802.3 working group. The objectives are intended to maximize the usage of the installed base of cabling and minimize the changes to the existing PoE standard in order to maintain backward compatibility. The objectives have expanded over time and now include:

- Use of all four pairs of balanced twisted-pair cabling
- Operation with 10 Mb/s, 100 Mb/s, 1G, 2.5G, 5G and 10GBASE-T with delivery of at least 49 watts to the PD
- Compliance to ISO/IEC 60950 regarding separated or safety extra low voltage (SELV) circuits
- Support for Category 5e cabling or higher

In order for the study group to progress to an official IEEE task force, group members also addressed how the four-pair PoE standard would relate to the five key criteria defined by IEEE.

1. Broad market potential—PoE market analysts estimate the size of the market today at 100 million powered devices worldwide.
2. Compatibility—All enhancements to existing PoE standards will be compatible with 10BASE-T, 100BASE-TX, 1000BASE-T and 10GBASE-T with no changes to these interfaces.
3. Distinct identity—IEEE 802.3bt will specify the use of all four unused pairs. The information exchanged between the PSE and PDs will allow for enhanced power management capabilities. As a result, the new standard will address the need for higher power and more efficient power delivery systems.
4. Technical feasibility—Four-pair PoE has been successfully tested and reliably used for years. Numerous system and silicon vendors are currently using proprietary technologies to manufacture PoE products that exceed the current 25.5-watt limit.
5. Economic feasibility—Utilizing unused wire pairs to carry power increases efficiency and power delivery at no additional cabling cost. Demonstrated PoE installation costs are also typically much lower than traditional methods involving separate power distribution systems.

As of the writing of this paper, the IEEE four-pair PoE Study Group has officially advanced to the status of the IEEE 802.3bt Task Force and is currently developing the four-pair PoE standard, which is expected to be published in 2018.

Recommendations

CommScope recommends the following to allow additional margin and flexibility for four-pair PoE:

Category 6A cabling—To improve thermal performance and energy efficiency while minimizing the cost of moves, adds, changes and upgrades CommScope recommends running Category 6A cabling to each powered device, preferably using a zone cabling architecture.

Diversity of power delivery—In order to accommodate future capacity upgrades and ensure diversity in power delivery, it is also suggested that network managers plan for at least two runs of Category 6A cabling per powered device to each zone distributor. This will allow each device to be powered from two different zone distributors.

Reliability testing—If connectors are unplugged under load, an inductive current is created within the connector that may spark at one or more contact surfaces, causing the surfaces to corrode. It is recommended that connecting hardware be qualified to support PoE and four-pair PoE applications by using the test schedules in IEC 60512-99-001.

Rely on CommScope to keep you updated

The continuing work of the IEEE 802.3bt Task Force is fueled, in large part, by the continued flow of new and higher powered four-pair PoE products and devices. Even without the final and adopted standards, this enhanced technology is already facilitating and enabling more efficient higher power applications in commercial and industrial premises.

Once the new standards are adopted, they will improve the interoperability and portability of these new LAN devices. At CommScope, it is our job to keep the industry informed as to the progress of these efforts. Hopefully, initiatives such as this paper will help keep you and your colleagues abreast of what is happening in the PoE market and provide some guidance on how these changes will affect the design, capabilities and performance of today's advanced enterprise networks. We invite you to look for future updates on the IEEE 802.3bt Task Force activity as they close in on adopting a final four-pair PoE standard.

Bibliography

1. Four-Pair PoE Requirements and Considerations May 2013 IEEE 802.3 CFI
2. Four-Pair PoE Objectives IEEE 802.3 meeting of July 2013
3. Four-Pair PoE Criteria IEEE 802.3 meeting of July 2013
4. ANSI/TIA-568-C.2 Balanced Twisted-Pair Telecommunications Cabling and Components Standard
5. IEEE Std 802.3™-2012, IEEE Standard for Ethernet
6. IEC 60512-99-001 Optional reliability test schedules for modular connecting hardware
7. ISO/IEC 11801, Information Technology—Generic cabling for customer premises
8. CENELEC EN 50173 Information Technology Generic Cabling Systems
9. ISO/IEC TR 29125: Information technology—Telecommunications cabling requirements for remote powering of terminal equipment
10. CENELEC TR 50174-99-1: Information technology—Cabling installation—Part 99-1: Remote powering

References

- ¹ Power over Ethernet (PoE) Seeks to Extend Reach with Higher Efficiency, Faster Data Rates; The DataCenter Journal; July 1, 2013
- ² IEEE 802.3af-2003; Microsemi
- ³ Extending Power-over-Ethernet technology for security; August 6, 2012
- ⁴ Universal Connectivity Grid; www.commscope.com/Solutions/Universal-connectivity-grid/; March 2015

Everyone communicates. It's the essence of the human experience. *How* we communicate is evolving. Technology is reshaping the way we live, learn and thrive. The epicenter of this transformation is the network—our passion. Our experts are rethinking the purpose, role and usage of networks to help our customers increase bandwidth, expand capacity, enhance efficiency, speed deployment and simplify migration. From remote cell sites to massive sports arenas, from busy airports to state-of-the-art data centers—we provide the essential expertise and vital infrastructure your business needs to succeed. The world's most advanced networks rely on CommScope connectivity.

COMMSCOPE®

commscope.com

Visit our website or contact your local CommScope representative for more information.

© 2017 CommScope, Inc. All rights reserved.

All trademarks identified by ® or ™ are registered trademarks or trademarks, respectively, of CommScope, Inc. This document is for planning purposes only and is not intended to modify or supplement any specifications or warranties relating to CommScope products or services. CommScope is committed to the highest standards of business integrity and environmental sustainability, with a number of CommScope's facilities across the globe certified in accordance with international standards, including ISO 9001, TL 9000, and ISO 14001. Further information regarding CommScope's commitment can be found at www.commscope.com/About-Us/Corporate-Responsibility-and-Sustainability.

WP-107291.4-EN (04/17)