

860481019
 Revision D / Nov. 2022
 commscope.com

M2400 and M2400A Patch Panel Instructions

General

The M2400 and M2400A modular panels are highly flexible 24-port, front or rear accessible patch panel assemblies available in **GigaSPEED®**, **PowerSUM**, or **UNJ** configurations. When installed with M-series or **UNJ** information outlets, modular patch cords, and cables, they are an integral part of the **CommScope®** connectivity system. The panels mount in a standard 19-inch (483 mm) equipment rack with universal hole spacing.

Ordering information is listed below:

Material ID	Part No.	Description
760118323	M2400-1U-GS	M2400 GS panel (GigaSPEED)
760118315	M2400-1U-PS	M2400 PS panel (PowerSUM/UNJ)
760118349	M2400A-1U-GS	M2400A GS panel (GigaSPEED)
760118331	M2400A-1U-PS	M2400A PS panel (PowerSUM/UNJ)
760253535	M2400A-1U-GS-WH	M2400A GS panel (GigaSPEED)

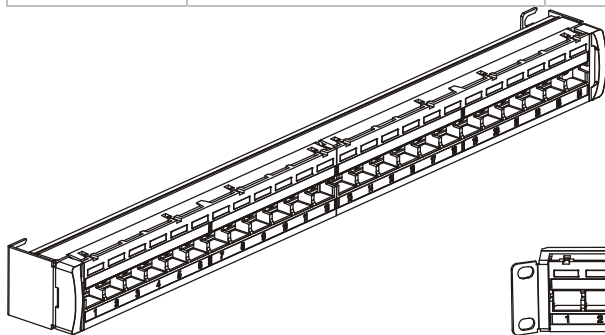

M2400 Patch Panel

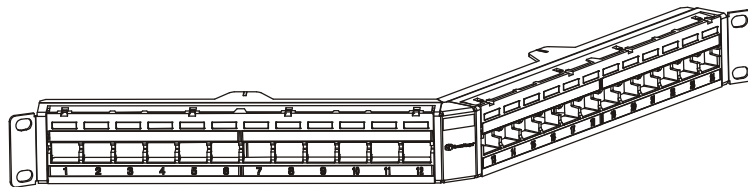

M2400A Patch Panel

How to Contact Us

- To find out more about **CommScope®** products, visit us on the web at <http://www.commscope.com/>
- For technical assistance:
 - Within the United States, contact your local account representative or technical support at 1-800-344-0223. Outside the United States, contact your local account representative or Authorized Business Partner.
 - Within the United States, report any missing/damaged parts or any other issues to CommScope Customer Claims at 1-866-539-2795. Outside the United States, contact your local account representative or Authorized Business Partner.

Tools Required

- Phillips head screwdriver



Parts List

Verify parts against the parts list below:

M2400 Panel		M2400A Panel		Description
PS	GS	PS	GS	
1	1	—	—	M2400 panel assembly
—	—	1	1	M2400A panel assembly
2	2	—	—	Panel end caps
24	—	24	—	MPS/UNJ outlet caps
—	24	—	24	MGS outlet caps
4	4	4	4	12-24 x 1/2" mounting screws
2	2	2	2	Label sheet
1	1	1	1	Instruction sheet

Separately Orderable Items

A separately orderable rear cable management bar is available for use with the M2400/M2400A panel and a separately orderable removal tool kit is required for use with the panel.

Material ID	Description
760104737	Rack mountable rear cable management bar
760122713	Outlet removal tool kit (5 pack)

Step 1A – M2400 Flat Panel Installation (Skip to Step 1B for Installation of M2400A Angled Panel)

Install Mounting Screws

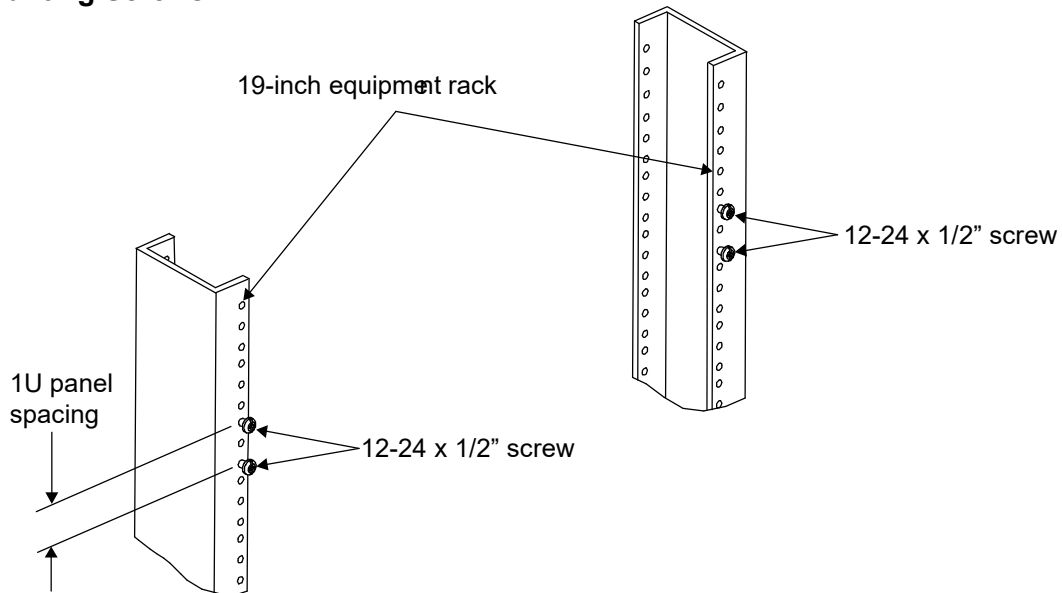

1. Partially install four 12-24 x 1/2" screws in equipment uprights in a 1U panel spacing as shown.

Install Panel on Rack

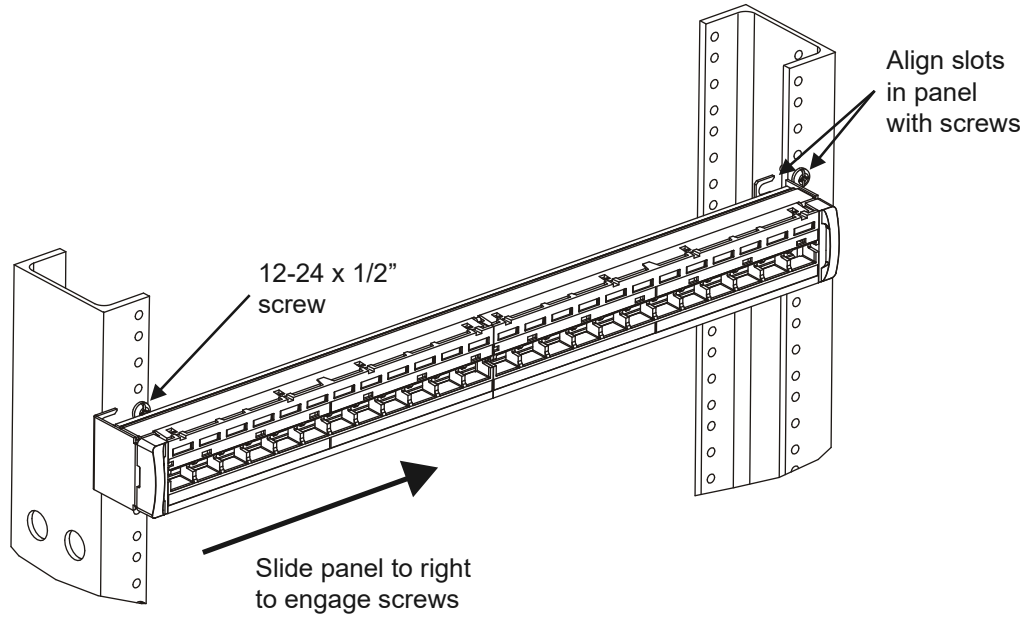

1. Position panel against rack rails offset to the left of the partially installed screws.
2. Align slots in panel with screws and slide panel to right to engage screws.

Secure Panel to Rack

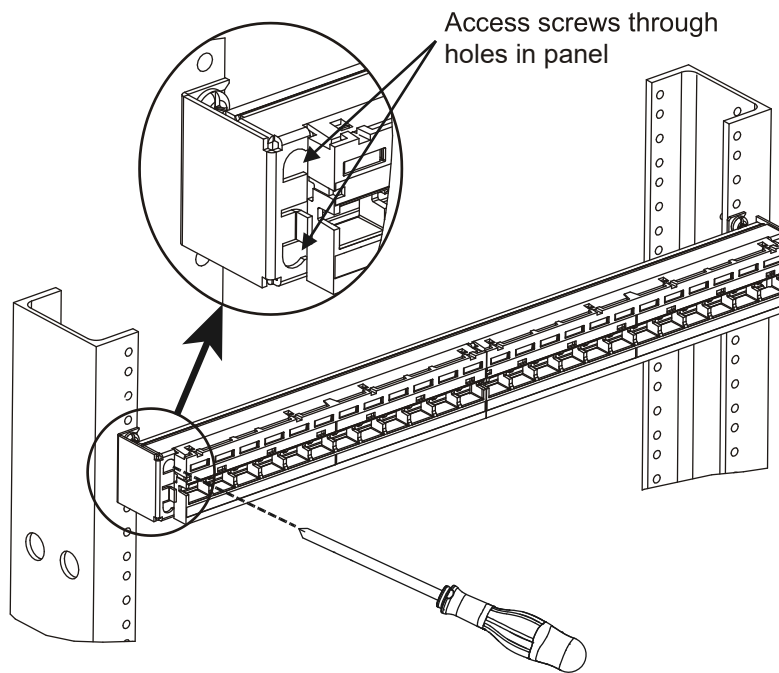

1. Use a screwdriver to access screws through holes in panel. Tighten screws to secure panel to rack.

Install End Caps

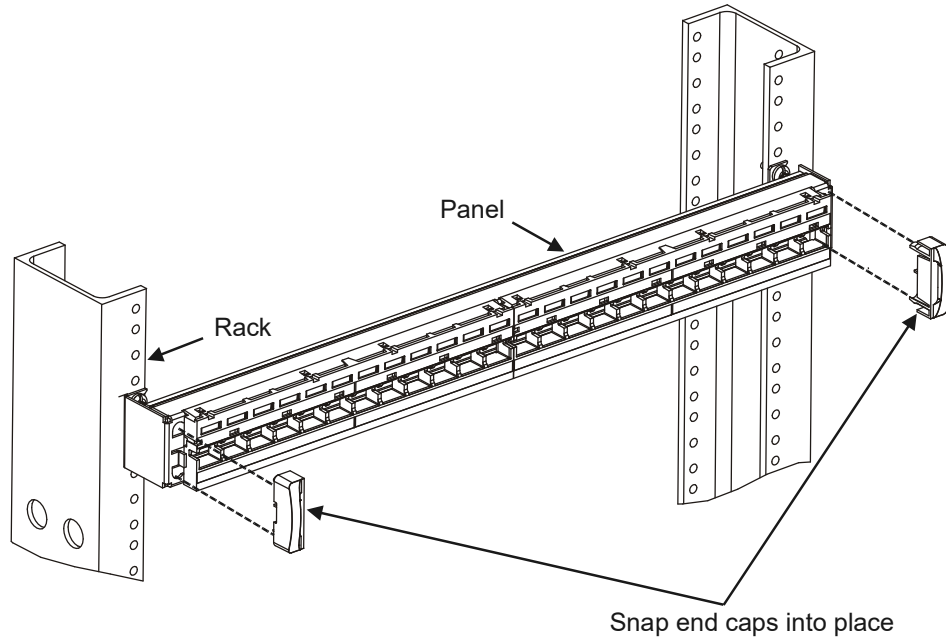

1. Snap end caps into place on panel as shown.

Step 1B – M2400A (Angled) Panel Installation

Install Panel on Rack

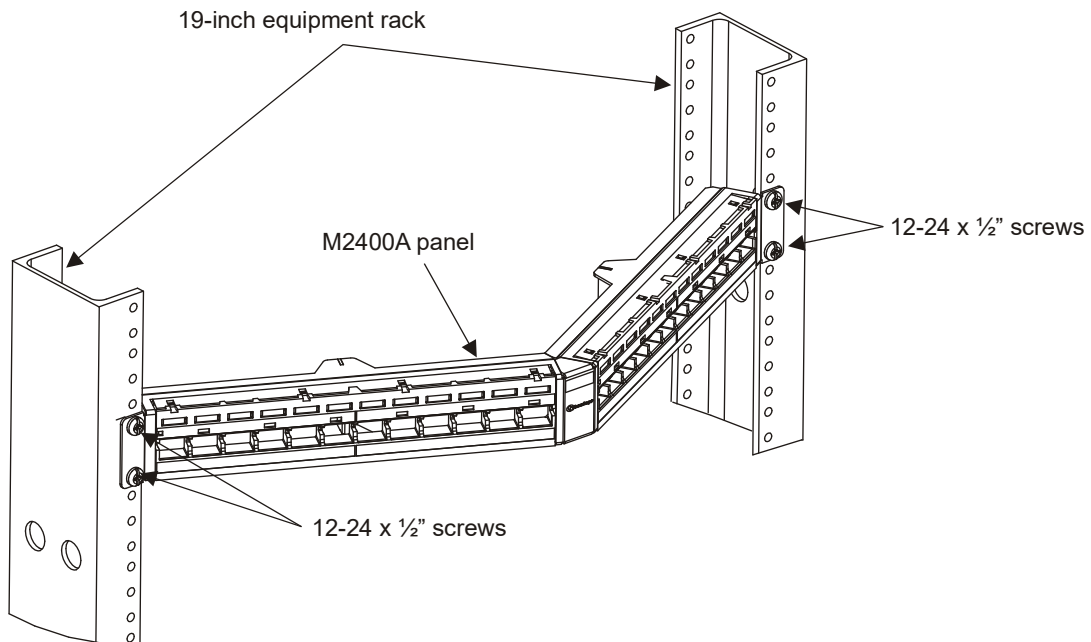

1. Use four supplied 12-24 x 1/2" screws to secure panel to rack.
2. Connect cables to outlets per instructions provided with the individual outlets.

Step 2 — Attach Separately Orderable Cable Management Bar

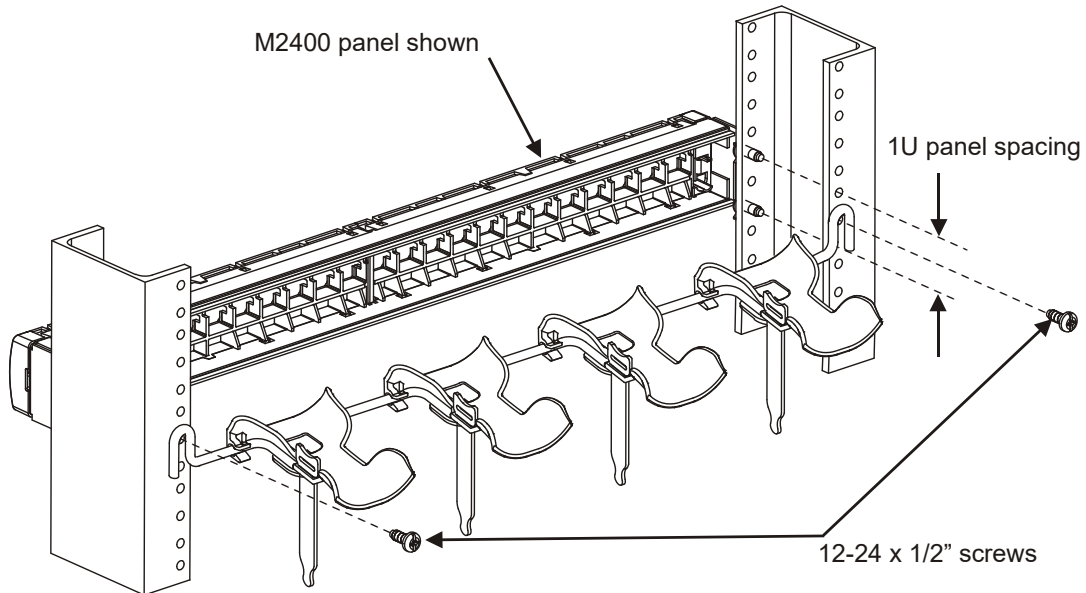

1. Attach cable management bar to rear of equipment rack using the four provided 12-24 x 1/2" screws as shown. Bar should be level with lower row of outlets.
2. Assemble cable management bar components per instructions provided with the bar.

Step 3 – Terminate Outlets, Install Modular Caps on Outlets, and Populate Panel

1. Terminate cables to outlets per the instructions provided with the individual outlets.

Note: 1a. For the MGS jack use a D914 (406477794) impact tool (on HI setting) with M110 cutting blade and hand puck (760034215) or the *JackRapid** (JR-SYS-2) termination tool to punch down conductors. Trimming conductors with side-cutters or fine edge cutters is not allowed due to the tight spacing of the outlets.

1b. For the UNJ jack, use a D914 impact tool (on HI setting) with M110 cutting blade and hand puck 569949-1 or SL Series termination tool 1725150-1

2. After termination of outlets, snap the provided modular caps onto the outlets.
3. Populate the panel with outlets, then using the instructions provided with the cable bar, route and secure cables to bar using the provided hook-and-loop straps.

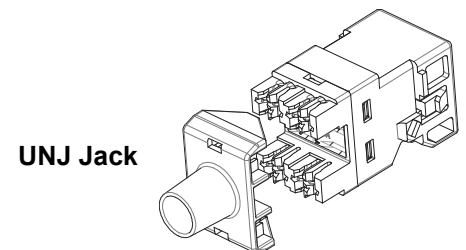
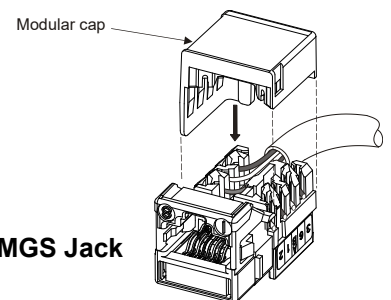

*Trademark of Fluke Networks.

Step 4 – Install Port Designation Labels and Icons

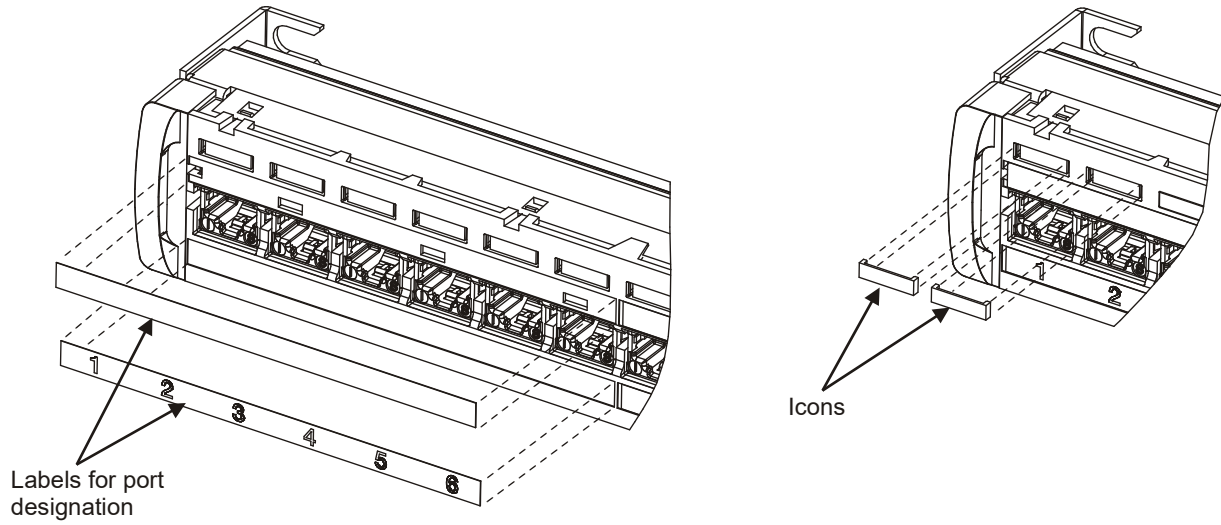

1. Apply labels and icons to front of panel as shown for port designation.

Step 5 – Using Module Removal Tool (Part of Removal Tool Kit 760122713)

To Remove End Cap

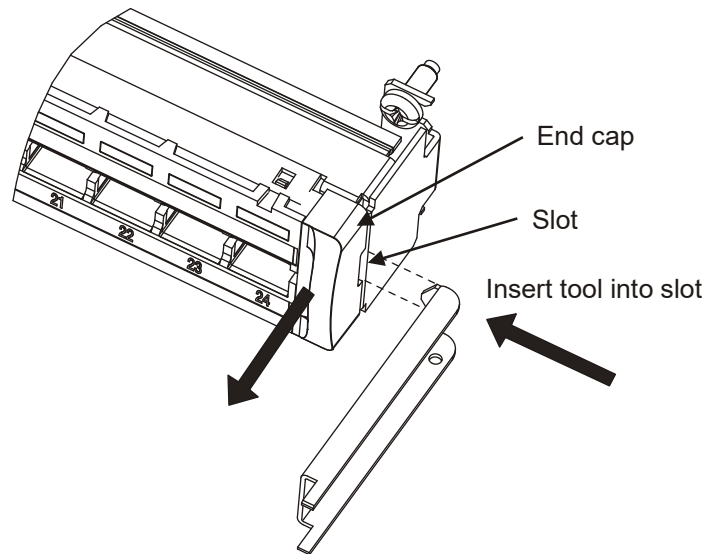

1. Insert provided tool into slot as shown.
2. Use tool to pry end cap loose from panel.

To Remove an Outlet

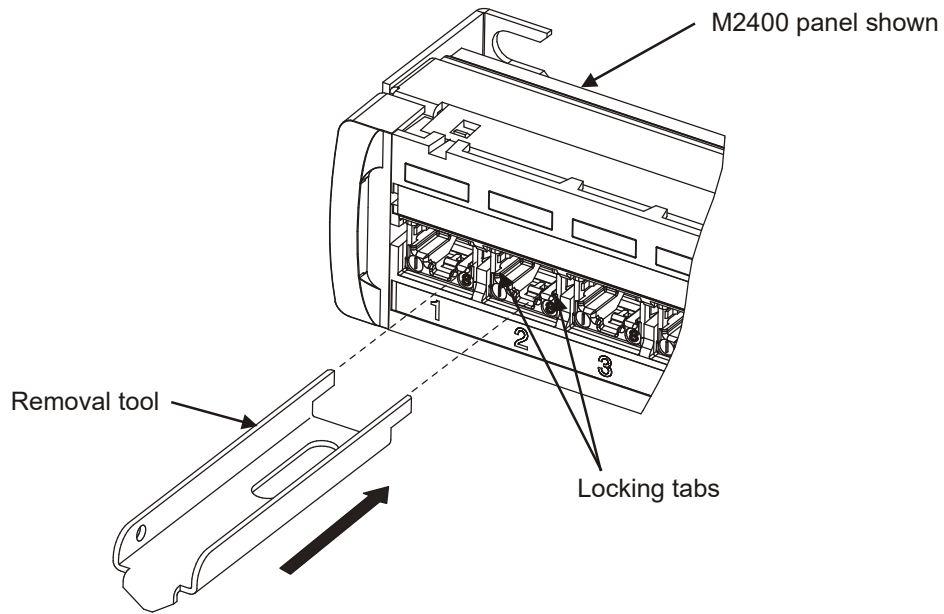

1. Position tool as shown and insert into front of outlet to depress locking tabs.
2. Remove outlet from rear of panel.

To Remove Modular Cap

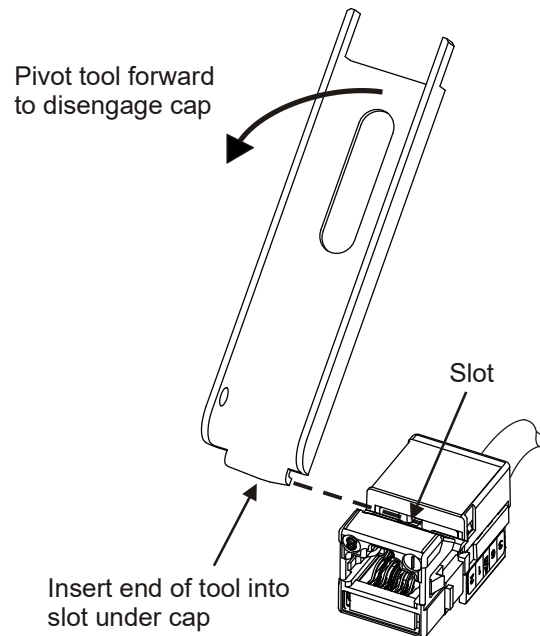

1. Insert tool into slot as shown and pivot forward to disengage modular cap for removal from outlet.