

# Maintaining The Power Advantage In HFC Networks

A Technical Paper prepared for SCTE/ISBE by

**John Chamberlain**

Director, Office of the CTO  
CommScope  
1100 CommScope Place SE, Hickory, NC 28603  
828.431.9800  
John.Chamberlain@commscope.com

**Mark Alritz**

Director, Field Applications Engineering  
CommScope  
6519 CommScope Road, Catawba, NC 28609  
828.241.6492  
malritz@commscope.com

## Table of Contents

<b>Title</b>	<b>Page Number</b>
Introduction	3
A Tale of Two Networks	3
Network Convergence .... Small Cell Wireless in HFC	6
Requirements for Convergence	7
1. Power	7
2. Backhaul	10
3. Site Availability	10
Conclusion	10
Abbreviations	12
Bibliography & References	12

## List of Figures

<b>Title</b>	<b>Page Number</b>
Figure 1 – Evolution of DSL	4
Figure 2 - FTTH PON Network	4
Figure 3 - HFC Network	5
Figure 4 - Convergence in the Access Network	6
Figure 5 - Network Convergence	7
Figure 6 - Fiber and Coaxial overlay in HFC	8
Figure 7 - Power consumption in HFC	9
Figure 8 - Access Point Power Requirements	9
Figure 9 - Concealed Access Point in Underground Plant	10



## Introduction

Network convergence has been defined as “The efficient coexistence of telephone, video and data communication within a single network. The use of multiple communication modes on a single network offers convenience and flexibility that are not possible with separate infrastructures.”

By that definition the CATV (Community Antenna Television)/Broadband industry has been a “Converged Network” in and of itself since the deployment of high speed data DOCSIS (Data over Cable System Interface Specification) and VoIP (Voice over Internet Protocol) systems over ten years ago. Although only implied in the statement above, it is the integration of wireless services in a “converged network”, of which the industry has also embraced in the way of millions of single dwelling unit and mobility Wi-Fi hotspots. Now the industry is also embracing the concept of “cellular” mobility on the same network, either through support of 4G/LTE densification or the implementation of 5G.

In all the current definitions of a converged network one feature is rarely mentioned but is of paramount importance .... the power required to run the network components. In particular, far-edge Access Point (AP) devices require power to operate. This is where the HFC (Hybrid Fiber Coax) architecture deployed by the industry shines. Where other industries have shed the cost of network powering infrastructure for short term gains and reduced OPEX (operations expense), the MSO (Multiple System Operator) industry has maintained network powering to activate signal amplifiers for the coax portion of the HFC network. Power is required every 50-500 meters for the mass deployment of LTE densification and 5G mobility and only HFC networks have the network powering budget required to meet these needs.

## A Tale of Two Networks

As an introduction to where the networks are now, a short history of these communication networks is in order.

The Bell System first used -48 volts DC and 90 volts AC to power voice circuitry and the ringer on a phone respectively. Network powering was the only choice as the Bell System required reliability beyond what the power grid could provide. The Bell System pioneered the term “five 9’s” meaning 99.999% reliability. -48 volts DC was chosen as a voltage high enough to allow for voltage drop in a distance defined “local loop” and still power the talk circuit terminal devices. The higher AC voltage was needed intermittently to ring the bell on the phone. In addition, at the time, DC was considered a safer voltage and could be powered with batteries. Negative 48 volts DC to ground was chosen to minimize electrolysis and galvanic corrosion to the conductors and connection points. The power requirements at the terminal equipment were low, on the order of tens of milliamps.

Evolution of DSL

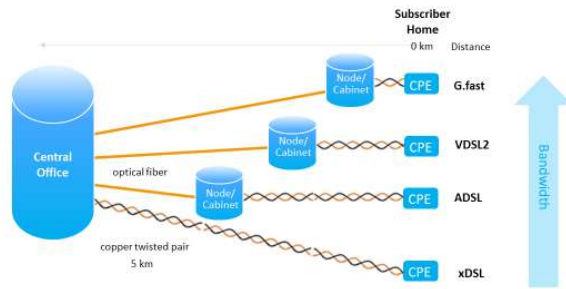

Figure 1 – Evolution of DSL

The twisted pair or “tip and ring” cabling deployed by the legacy telephony carriers has limited bandwidth. The original system was built for 4 KHz voice signals.

Companding, the process of compressing and subsequently decompressing signals, and digital compression and modulation schemes eventually allowed for higher delivered effective bandwidths. First, with telephone modems, and then with the advent of optical or electrical Digital Loop Carriers, and subsequently the shortening of the twisted pair portion of the plant, higher bandwidths and data rates could be achieved through ADSL, VDSL, and G.fast technologies.

As the Bell system matured, the legacy powering system remained in place until the mass deployment of fiber optics and Fiber to the Home (FTTH). FTTH was driven by the consumer need for bandwidth that the legacy twisted pair plant could not deliver. By definition, PON (Passive Optical Networks) are all passive and the only power required in the system is at the terminal unit or in PON vernacular, the ONT. (Optical Network Terminal) This CPE (Consumer Premise Equipment) is powered by the consumer. This created a high bandwidth system with no network powering. No network powering means less OPEX but no access to power in the plant other than through power utility company drops or consumer/enterprise power.

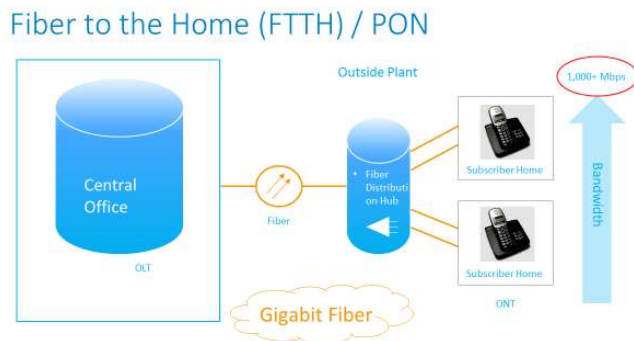

Figure 2 - FTTH PON Network

When legacy CATV systems were being built, 75-ohm coaxial cable was used to transmit AM (Amplitude Modulated) RF (Radio Frequency) signals from a “Head End” to the end users. The attenuation of the coaxial cable at the RF frequencies in use, is such that the AM signal needed to be amplified approximately every 2500 feet. The RF amplifiers needed to be powered. The most economic and controlled way to do so was network powering. At the peak of coaxial cable deployment, before HFC, cascades of amplifiers as high as 40 were not unheard of. The power system chosen to power these amplifiers along the length of coaxial cable was 60 HZ, trapezoidal AC. Early networks were powered using 60-volt power supplies, but as power demand of network elements increased, standards and regulations were changed to allow 90-volt power supplies. This higher voltage has greatly improved network power utilization and effectively reduced voltage drop and current draw due to more efficient activation of constant power devices. Typically, the power is inserted periodically along the length of the coaxial cable and provides up to 15 amperes of service. There are also designs where power is expressed along a parallel coaxial path, in some cases dedicated for that purpose. This approach allows power supplies to be more conveniently located, and lower resistance cables can be used to minimize voltage drop.

### Hybrid Fiber Coax (HFC)

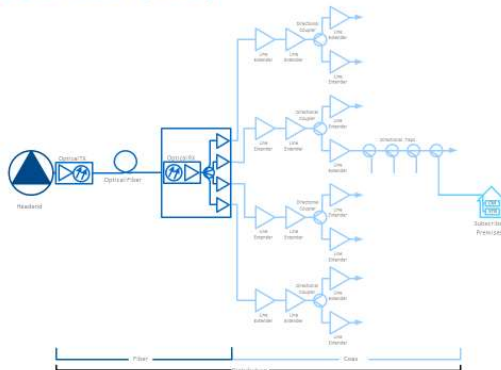

Figure 3 - HFC Network

In the case of the legacy CATV networks fiber was initially installed to reduce amplifier cascades which greatly reduced noise in the system and increased quality of service due to shorter amplifier cascades and the associated reduction in outages. The HFC plant has always had high bandwidth as a requirement for AM and later digital video delivery (1 GHz) and this bandwidth has been maintained or increased as fiber has been deployed deeper into the HFC network. In addition, in an HFC network, network powering has been maintained as the last part of the access/distribution network is still coaxial cable and remains amplified. The HFC architectures designated Node + 1,2,3, etc. refer to the maximum amplifier cascade in each design. This evolution has created a high bandwidth/data rate capable plant with access to power.

Node +0 or “fiber deep” network designs are built around the concept of eliminating amplifiers. In these designs, there is no cascade of amplifiers between the optical node and the subscriber. Power remains a requirement in these networks as well, since the nodes themselves are active devices which require power to operate, typically on the order of 1000 watts.

## Network Convergence ... Small Cell Wireless in HFC

The ubiquitous need for bandwidth in our internet centric world has driven these two networks, as well as more recently deployed wireless networks, to something referred to as “Network Convergence”. In the end, all networks are moving toward delivering high speed digital data from a data or processing source, through a high bandwidth or “broadband” network, to a wireless distribution point and reverse for the upstream.

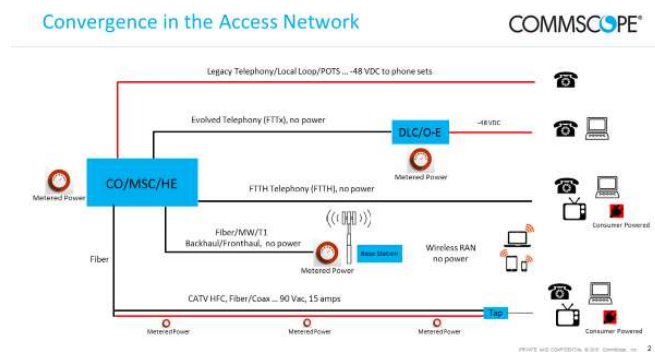

Figure 4 - Convergence in the Access Network

The next network architecture evolution is 4G/LTE densification and 5G wireless. This evolution is an evolution of fixed and wireless access points. Current LTE coverage in North America is relatively ubiquitous. Wireless “coverage” is complete, for all intents and purposes. The issue, as consumer demand for data increases, is capacity. Wireless capacity can be increased in several ways. Better modulation techniques, more spectrum, or spatially. 4G/LTE densification and potentially 5G mobility create more capacity spatially. More small cells closer to each other (250 meters) means that there are less users at each access point which effectively creates more bandwidth per square meter. This is the drive for 4G /LTE densification and potentially 5G. The promise of fixed wireless 5G in the millimeter wave band (i.e. 28GHz) creates more bandwidth with additional spectrum. For instance, in the 28 GHz band there is up to 800 MHz of spectrum to provide fixed broadband as a competitor to HSD from the MSOs.

In the MSO or legacy CATV network there is a headend, connected via router to data centers. The network consists of a high bandwidth HFC network. At the consumer/enterprise end of the network the obvious trend is toward Wi-Fi wireless connectivity in the home, or in the office. In the legacy telephony carrier network the same is true, with the exception of the delivery network described above. The high bandwidth HFC network is instead replaced by a legacy copper network, a version of FTTN (Fiber to the Node) supporting some form of advanced DSL services, or a FTTH network. As in the HFC example, home and business routers and Wi-Fi are typically activated. A traditional cellular network is comprised of a network of macrocells, each independently powered and interconnected by a backhaul network of varying types, inclusive of fiber, HFC, copper and microwave. Options exist to activate Wi-Fi networks

as an additional AP within a cellular wireless network, but these are less common due to the availability of 4G/LTE service with its associated mobility.

These three different networks, 1) legacy telephony carrier TP/FTTx, 2) Legacy CATV broadband HFC and 3) the mobility wireless networks all looked different when deployed due to the need to meet different communications applications, but are now all beginning to resemble each other to the point the networks can, and will merge into one, saving operator OPEX and CAPEX as equipment requirements also become identical ..... This is network convergence. It not only drives the networks toward looking the same, but capex will be reduced as white-box manufactures and NPV/SDN (Network Virtualization / Software Defined Networks) become standard.

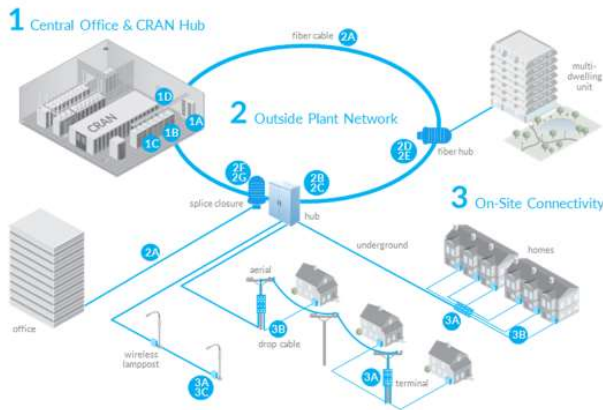

Figure 5 - Network Convergence

## Requirements for Convergence

In a converged network three things are required, sometimes referred to as PBS:

- 1) Power (for wireless access points, as well as other edge devices)
- 2) Backhaul (data from the edge APs to the central data storage or processing centers)
- 3) Site acquisition

### 1. Power

The HFC network is well suited for Network Convergence. In fact, an argument could be made the HFC network IS already a converged network as, to date, the number of Wi-Fi hotspots has reached about 500,000.

Estimates are that 80% of HFC plant miles whether coax or fiber have network power availability due to the power on the coax. Coax in many cases runs parallel as a back-feed from an optical node thereby



creating power availability even in fiber portions of the plant. In most cases the power availability is more than adequate for Wi-Fi hotspots or Small Cells.

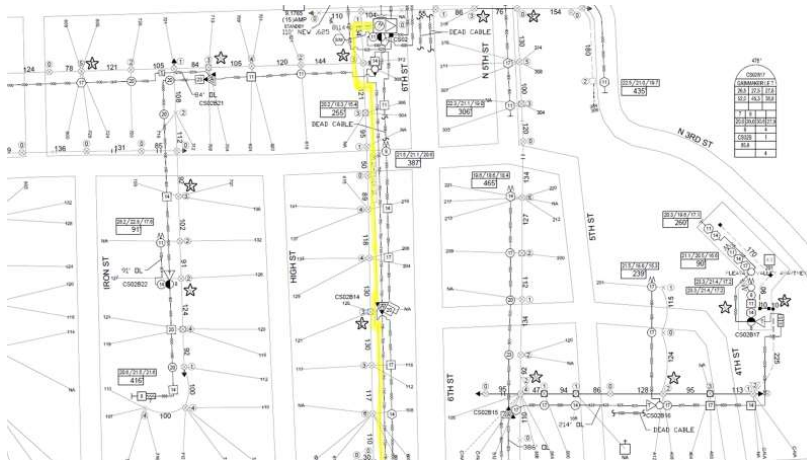
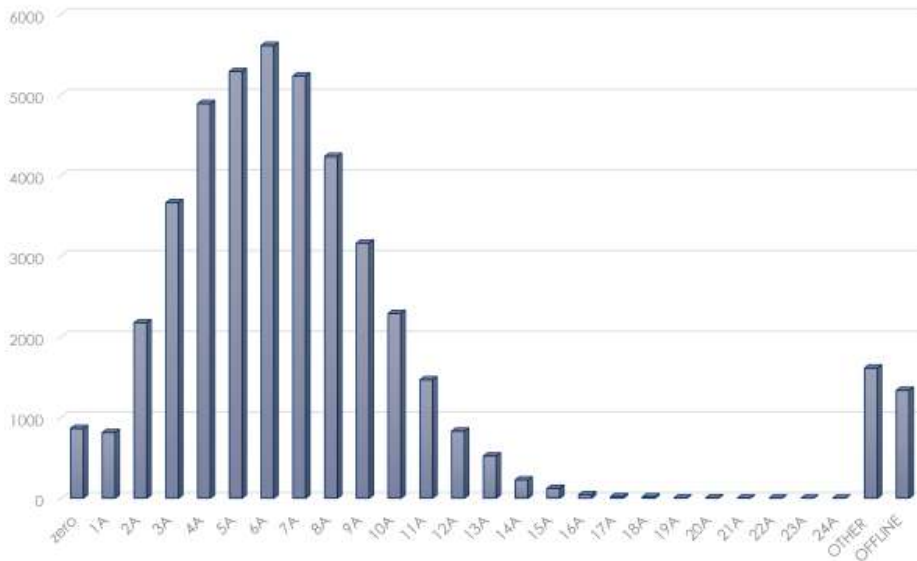

Figure 6 - Fiber and Coaxial overlay in HFC

Typically, 15-amp service at 90 VAC is available, and industry Pareto analysis shows and average usage of only 7-8 amps. On average that leaves 600 watts of unused power, more than enough for wireless APs whether Wi-Fi or LTE/5G small cells distributed along the plant, which may operate at lower than 50 watts each.





Current Range	Category
X<1	ZERO
1<2	1A
2<3	2A
3<4	3A
4<5	4A
5<6	5A
6<7	6A
7<8	7A
8<9	8A
9<10	9A
10<11	10A
11<12	11A
12<13	12A
13<14	13A
14<15	14A
15<16	15A
16<17	16A
17<18	17A
18<19	18A
19<X<20	19A
20<21	20A
21<22	21A
22<23	22A
23<24	23A
24<25	24A
X=N/A	OTHER
X=99999.9	OTHER
OFFLINE	OFFLINE



Copyright © 2017 Alpha Networks Inc. All rights reserved.

Figure 7 - Power consumption in HFC

Small Cells/Wireless Access Points

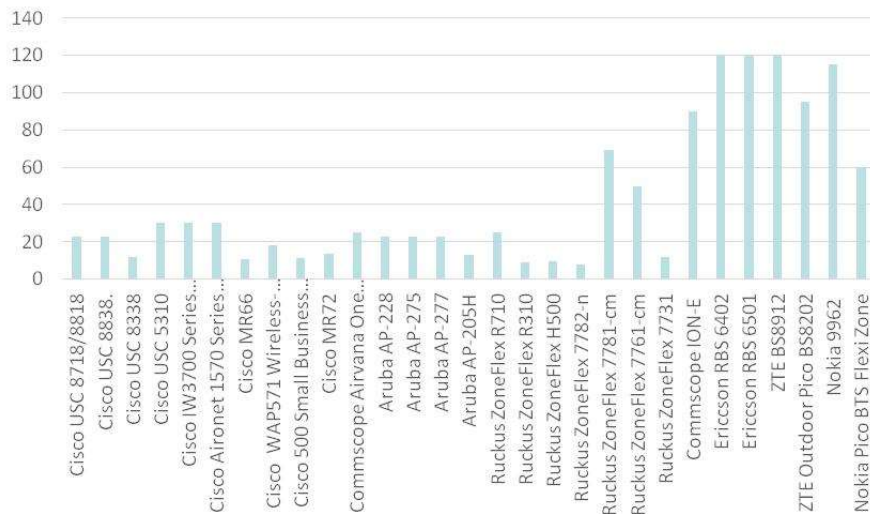

Figure 8 - Access Point Power Requirements

FTTH PON networks simply do not have this access to power, apart from the installation of a utility drop and meter installation. While a utility drop can be acquired at reasonable cost, and perhaps in a

reasonable timeframe, the installation of a utility drop at hundreds or thousands of AP locations will quickly become both an economic burden as well as a project bottleneck.

## 2. Backhaul

In an existing HFC network, backhaul capacity can be provided in several ways. DOCSIS provides connectivity over either coaxial or fiber links, and current deployments of DOCSIS 3.1 enable interconnect speeds in the Gbps range. Additionally, many HFC installations provide direct fiber connectivity over previously installed dark fiber, or over channels provided on existing fiber using available WDM (wavelength division multiplexing) paths. Equipment to condition power from the HFC plant to activate wireless APs via PoE (power over Ethernet) while providing a DOCSIS channel also exist. For small cells, depending on the technology deployed, tight timing and latency requirements are a concern, but these issues are currently being addressed in standards organizations.

## 3. Site Availability

Going forward, the majority of wireless mobility to be deployed for LTE densification or 5G will be deployed in urban and suburban areas. Much of the HFC network is aerial in these geographies and lends itself to site acquisition. The 4g/LTE wireless densification effort is about capacity, not coverage and 20-30 feet in the air is adequate for the coverage of a small cell area, estimated at 50-500 meters inter-site distance to create the additional capacity desired. For underground plant, small cabinet based cells are available, with varying tower heights and a variety of concealment methods. These small calls can be very unobtrusive, and placed along right of way already established for pedestals and cabinets.

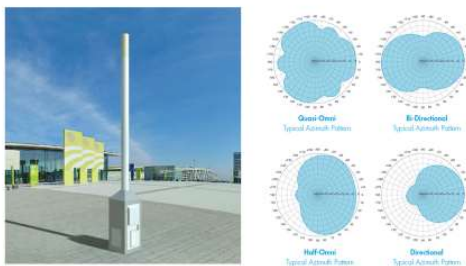

*Figure 9 - Concealed Access Point in Underground Plant*

# Conclusion



The HFC network, as deployed, with Power Availability, Backhaul Availability, and Site Availability is very well suited to 4G/LTE densification or 5G convergence. That competitive advantage should not be lost or forfeited as fiber extends deeper into the network or even FTTH architectures are deployed. In order to maintain the competitive advantage that HFC offers to a converged network, coaxial plant should be maintained as power distribution plant. This can be ensured even with the emergence of Node+0 architectures. In situations where coaxial plant does not exist or is impractical, hybrid cable constructions with power conductors placed within or alongside fiber cables can be utilized to retain access to network power.

## Abbreviations

AC	alternating current	HSD	high speed digital
ADSL	asymmetric digital subscriber line	Hz	hertz
AM	amplitude modulated	LTE	long term evolution
AP	Access Point	MSO	multi system operator
CAPEX	capital expenditures	NPV/SDN	network virtualization/software defined networks
CATV	community antenna television	ONT	optical network terminal
CPE	consumer premise equipment	OPEX	operating expenses
DC	direct current	PoE	power over Ethernet
DOCSIS	data over cable system interface specification	PON	passive optical networks
DSL	digital subscriber line	TP	twisted pair
RF	radio frequency	VDSL	very-high-bit-rate digital subscriber line
FTTH	fiber to the home	VoIP	voice over internet protocol
FTTN	fiber to the node	WDM	wavelength division multiplexing
GHz	gigahertz	xG	x generation
HFC	hybrid fiber coax		

## Bibliography & References

Munson, Ben, “Comcast, TWC ‘CableWifi’ shared network deal survives recent M&A hotspot count now 500M.” *Fierce Cable*. Questex, Jul 8, 2017. Web. Jul 17, 2017.