

4

3

2

1

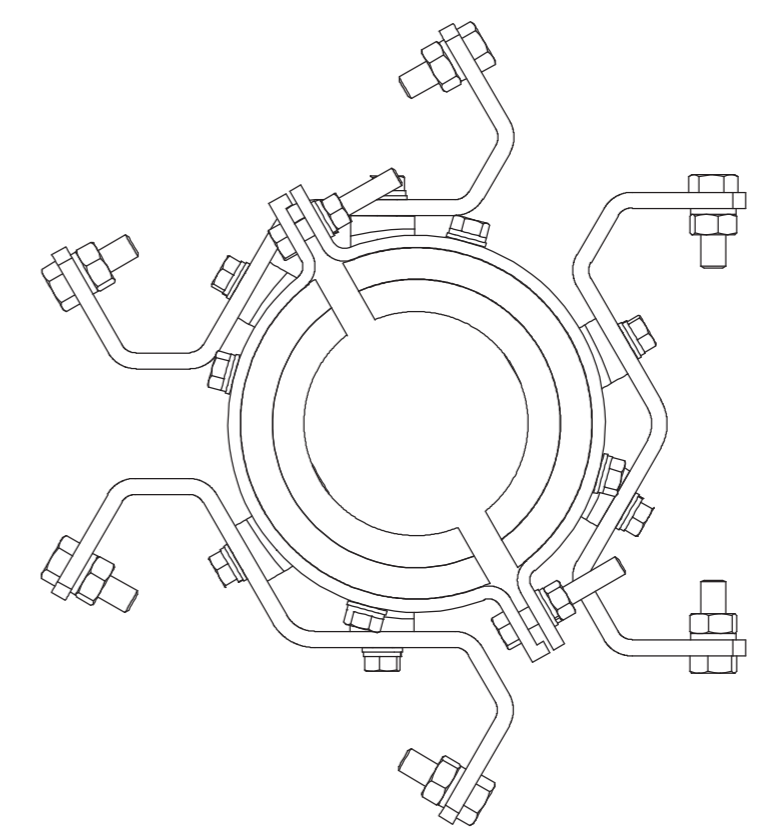
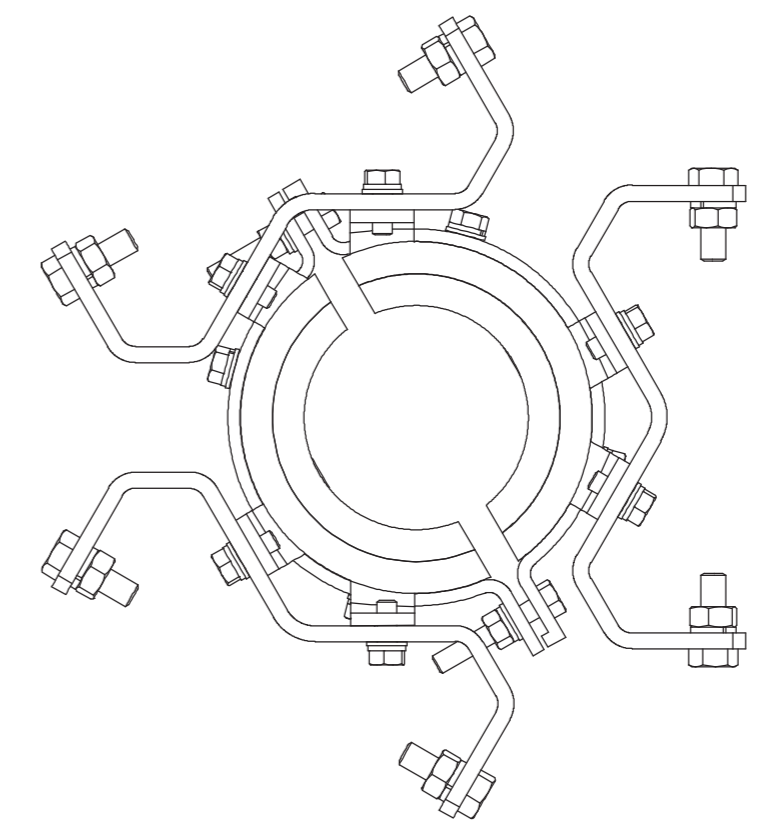
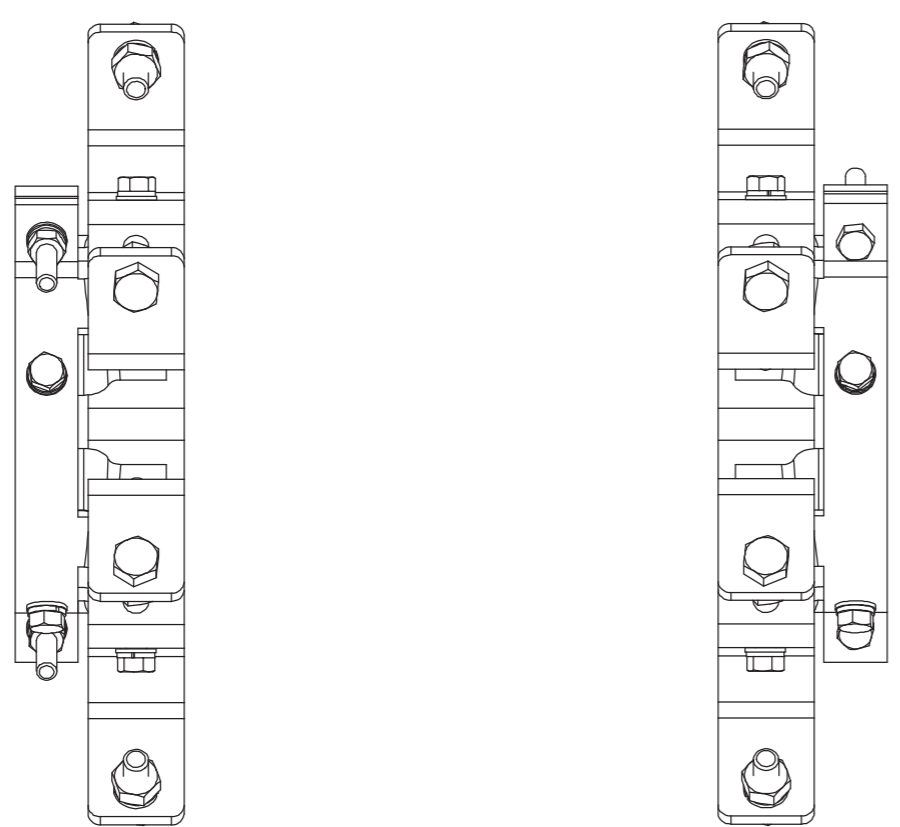
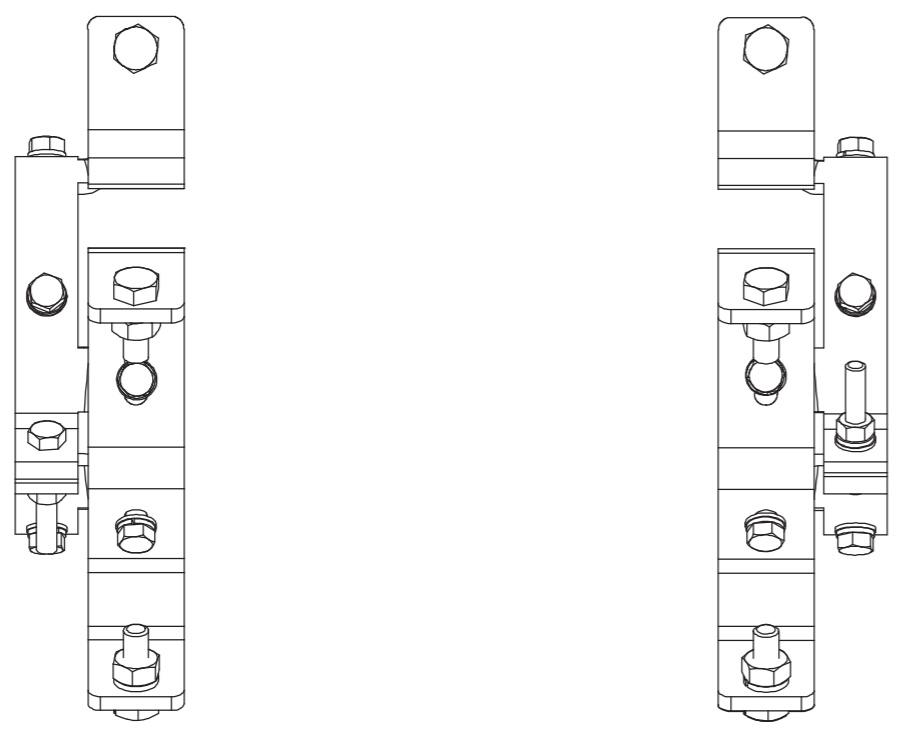

NOTES:

REVISIONS			
REV	DESCRIPTION	DATE	APPROVED
A	ECR 8000003574: REL TO PRODUCTION PER EAO 601665	13AUG14 JJH	MB XA



800PIPEKIT-X

CONFIDENTIAL

MATERIAL N/A	DENSITY: N/A MASS: 19.10 Kg	UNLESS OTHERWISE SPECIFIED DIMENSIONS ARE IN MILLIMETERS INTERPRET PER ISO STANDARDS HANDBOOK TECHNICAL DRAWINGS VOLUMES 1 & 2, THIRD EDITION (2002)	 WESTCHESTER, IL. 60154 U.S.A.	
FINISH N/A	TOLERANCES 0 PLACE X ± 1 PLACE .X ± 2 PLACE .XX ± ANGLES ± ALL SURFACES ✓		THIRD ANGLE PROJECTION 	
	DRAWN BY JJH 13AUG14 ECN 8000003574-O		SIZE A2 CAGE CODE 84147	DOCUMENT NO. 800PIPEKIT-X-L
NOTICE: These drawings and specifications are the proprietary property of ANDREW CORPORATION and may be used only for the specific purpose authorized in writing by Andrew.			AUTH. GROUP 23	MODEL DRAWING VERSION STATUS REVISION 00 RE A 01 RE B

4

3

2

1

SHEET
1 OF 1