

# F4A-PNMDF

## Base Product



HELIAX® 1/2" Superflexible SureFlex® Jumper with interface types N Male and 7-16 DIN Female, variable length

## Product Classification

<b>Product Type</b>	Wireless transmission cable assembly
<b>Product Brand</b>	HELIAX®   SureFlex®
<b>Product Series</b>	FSJ4-50B

## General Specifications

<b>Body Style, Connector A</b>	Straight
<b>Body Style, Connector B</b>	Straight
<b>Interface, Connector A</b>	N Male
<b>Interface, Connector B</b>	7-16 DIN Female
<b>Specification Sheet Revision Level</b>	A
<b>Variable Length</b>	For custom lengths contact 828-324-2200 or 1-800-982-1708 (toll free), or your local CommScope representative

## Dimensions

<b>Length</b>	0 m   0 ft
<b>Nominal Size</b>	1/2 in

## Electrical Specifications

<b>DTF, Connector A</b>	-32 dB
<b>DTF, Connector B</b>	-32 dB

## VSWR/Return Loss

Frequency Band	VSWR, typical	Return Loss, typical (dB)
0–3000 MHz	1.11	26
2.2–2.7 GHz	1.09	28

## Jumper Assembly Sample Label

# F4A-PNMDF



## Environmental Specifications

**Immersion Test Method** Meets IEC 60529:2001, IP68 in mated condition

## Regulatory Compliance/Certifications

Agency	Classification
ISO 9001:2015	Designed, manufactured and/or distributed under this quality management system

## Included Products

- F4DR-C – 7-16 DIN Male Right Angle for 1/2 in FSJ4-50B cable
- F4NR-HC – Type N Male Right Angle for 1/2 in FSJ4-50B cable
- L4DR-PS – 7-16 DIN Male Right Angle Positive Stop™ for 1/2 in LDF4-50A cable
- L4NR-PS – Type N Male Right Angle Positive Stop™ for 1/2 in LDF4-50A cable

# F4DR-C

---



7-16 DIN Male Right Angle for 1/2 in FSJ4-50B cable

## Product Classification

<b>Product Type</b>	Wireless and radiating connector
<b>Product Brand</b>	HELIAX®
<b>Product Series</b>	FSJ4-50B   FSJ4RK-50B
<b>Ordering Note</b>	CommScope® standard product (Global)

## General Specifications

<b>Body Style</b>	Right angle
<b>Cable Family</b>	FSJ4-50B
<b>Inner Contact Attachment Method</b>	Captivated
<b>Inner Contact Plating</b>	Gold   Silver
<b>Interface</b>	7-16 DIN Male
<b>Mounting Angle</b>	Right angle
<b>Outer Contact Attachment Method</b>	Self-flare
<b>Outer Contact Plating</b>	Trimetal
<b>Pressurizable</b>	No

## Dimensions

<b>Height</b>	42.42 mm   1.67 in
<b>Width</b>	34.54 mm   1.36 in
<b>Length</b>	70.87 mm   2.79 in
<b>Right Angle Length</b>	18.03 mm   0.71 in
<b>Nominal Size</b>	1/2 in

## Outline Drawing

# F4DR-C

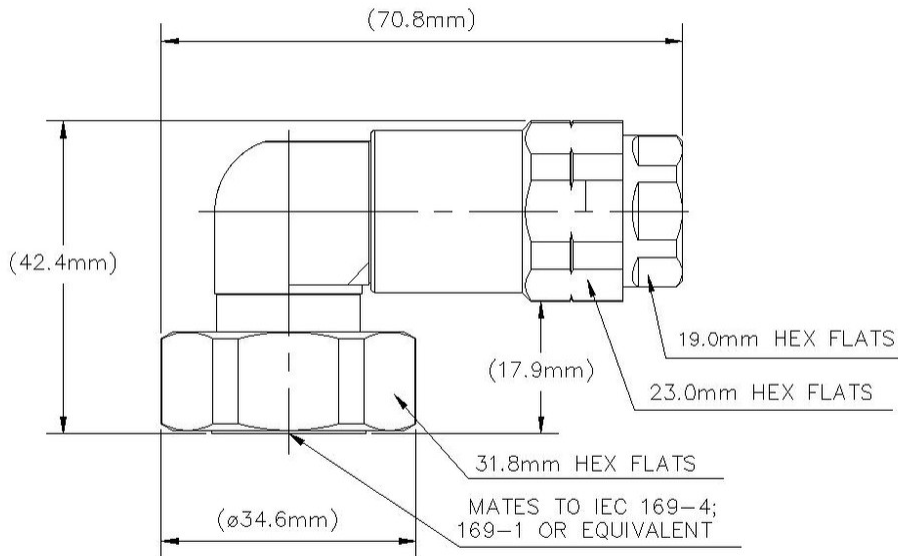

## Electrical Specifications

<b>3rd Order IMD at Frequency</b>	-120 dBm @ 910 MHz
<b>3rd Order IMD Test Method</b>	Two +43 dBm carriers
<b>Insertion Loss Coefficient, typical</b>	0.05
<b>Average Power at Frequency</b>	1.0 kW @ 900 MHz
<b>Cable Impedance</b>	50 ohm
<b>Connector Impedance</b>	50 ohm
<b>dc Test Voltage</b>	2500 V
<b>Inner Contact Resistance, maximum</b>	0.8 mOhm
<b>Insulation Resistance, minimum</b>	5000 MOhm
<b>Operating Frequency Band</b>	0 – 7500 MHz
<b>Outer Contact Resistance, maximum</b>	1.5 mOhm
<b>Peak Power, maximum</b>	15.6 kW
<b>RF Operating Voltage, maximum (vrms)</b>	884 V
<b>Shielding Effectiveness</b>	-110 dB

## VSWR/Return Loss

# F4DR-C

---

Frequency Band	VSWR	Return Loss (dB)
50–1000 MHz	1.04	34.16
1000–1900 MHz	1.04	34.16
1900–2200 MHz	1.07	29.42
2200–2700 MHz	1.1	26.45
2700–3600 MHz	1.13	24.29
3600–6000 MHz	1.25	19.09
6000–8800 MHz	1.67	12.01
8000–10200 MHz	1.67	12.01

## Mechanical Specifications

<b>Connector Retention Tensile Force</b>	444.82 N   100 lbf
<b>Connector Retention Torque</b>	5.42 N-m   47.998 in lb
<b>Coupling Nut Proof Torque</b>	24.86 N-m   220.003 in lb
<b>Coupling Nut Retention Force</b>	1,000.85 N   225 lbf
<b>Coupling Nut Retention Force Method</b>	MIL-C-39012C-3.25, 4.6.22
<b>Interface Durability</b>	500 cycles
<b>Interface Durability Method</b>	IEC 61169-4:9.5
<b>Mechanical Shock Test Method</b>	MIL-STD-202F, Method 213B, Test Condition C

## Environmental Specifications

<b>Operating Temperature</b>	-55 °C to +85 °C (-67 °F to +185 °F)
<b>Storage Temperature</b>	-55 °C to +85 °C (-67 °F to +185 °F)
<b>Attenuation, Ambient Temperature</b>	20 °C   68 °F
<b>Average Power, Ambient Temperature</b>	40 °C   104 °F
<b>Corrosion Test Method</b>	MIL-STD-1344A, Method 1001.1, Test Condition A
<b>Immersion Depth</b>	1 m
<b>Immersion Test Mating</b>	Unmated
<b>Immersion Test Method</b>	IEC 60529:2001, IP68
<b>Moisture Resistance Test Method</b>	MIL-STD-202F, Method 106F
<b>Thermal Shock Test Method</b>	MIL-STD-202F, Method 107G, Test Condition A-1, Low Temperature -55 °C
<b>Vibration Test Method</b>	MIL-STD-202F, Method 204D, Test Condition B
<b>Water Jetting Test Mating</b>	Unmated

# F4DR-C

---

**Water Jetting Test Method**

IEC 60529:2001, IP66

## Packaging and Weights

**Weight, net**

197.2 g | 0.435 lb

## Regulatory Compliance/Certifications

<b>Agency</b>	<b>Classification</b>
CHINA-ROHS	Below maximum concentration value
ISO 9001:2015	Designed, manufactured and/or distributed under this quality management system
ROHS	Compliant
UK-ROHS	Compliant



## \* Footnotes

**Insertion Loss Coefficient, typical** 0.05√freq (GHz) (not applicable for elliptical waveguide)

**Immersion Depth** Immersion at specified depth for 24 hours

# F4NR-HC



Type N Male Right Angle for 1/2 in FSJ4-50B cable

## Product Classification

<b>Product Type</b>	Wireless and radiating connector
<b>Product Brand</b>	HELIAX®
<b>Product Series</b>	FSJ4-50B   FSJ4RK-50B
<b>Ordering Note</b>	CommScope® standard product in Asia Pacific   CommScope® standard product in Europe, the Middle East, and Africa

## General Specifications

<b>Body Style</b>	Right angle
<b>Cable Family</b>	FSJ4-50B
<b>Inner Contact Attachment Method</b>	Captivated
<b>Inner Contact Plating</b>	Gold   Silver
<b>Interface</b>	N Male
<b>Mounting Angle</b>	Right angle
<b>Outer Contact Attachment Method</b>	Self-flare
<b>Outer Contact Plating</b>	Trimetal
<b>Pressurizable</b>	No

## Dimensions

<b>Height</b>	46.48 mm   1.83 in
<b>Width</b>	24.38 mm   0.96 in
<b>Length</b>	63.75 mm   2.51 in
<b>Right Angle Length</b>	22.1 mm   0.87 in
<b>Nominal Size</b>	1/2 in

## Outline Drawing

# F4NR-HC

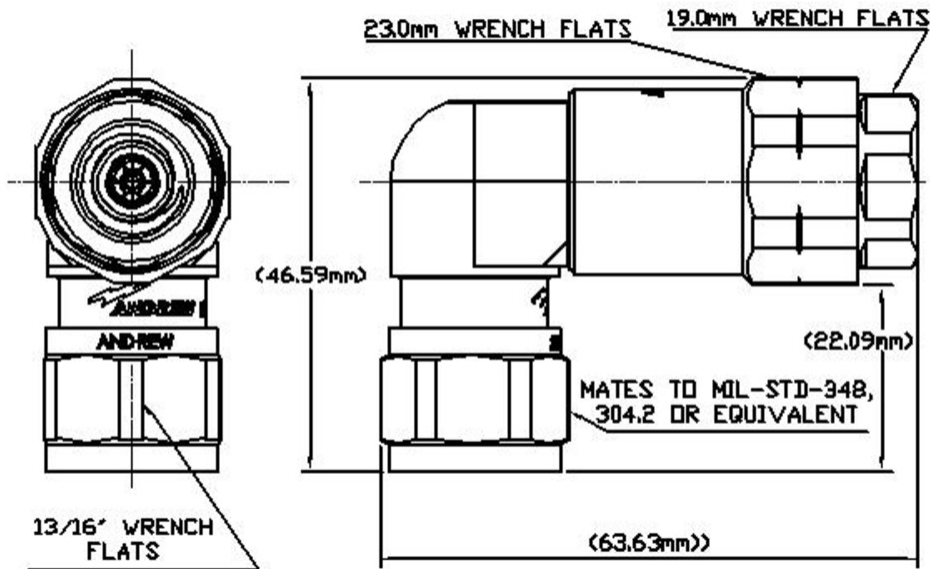

## Electrical Specifications

<b>3rd Order IMD at Frequency</b>	-116 dBm @ 910 MHz
<b>3rd Order IMD Test Method</b>	Two +43 dBm carriers
<b>Insertion Loss Coefficient, typical</b>	0.05
<b>Average Power at Frequency</b>	0.6 kW @ 900 MHz
<b>Cable Impedance</b>	50 ohm
<b>Connector Impedance</b>	50 ohm
<b>dc Test Voltage</b>	2000 V
<b>Inner Contact Resistance, maximum</b>	2 mOhm
<b>Insulation Resistance, minimum</b>	5000 MOhm
<b>Operating Frequency Band</b>	0 – 10200 MHz
<b>Outer Contact Resistance, maximum</b>	0.3 mOhm
<b>Peak Power, maximum</b>	10 kW
<b>RF Operating Voltage, maximum (vrms)</b>	707 V
<b>Shielding Effectiveness</b>	-110 dB

## VSWR/Return Loss

Frequency Band	VSWR	Return Loss (dB)
50–1000 MHz	1.05	32.26



# F4NR-HC

---

<b>1000–1900 MHz</b>	1.06	30.72
<b>1900–2200 MHz</b>	1.06	30.72
<b>2200–2700 MHz</b>	1.08	28.3
<b>2700–3600 MHz</b>	1.19	21.24
<b>3600–6000 MHz</b>	1.19	21.24
<b>6000–8800 MHz</b>	1.25	19.09
<b>8800–10200 MHz</b>	1.29	-18

## Mechanical Specifications

<b>Connector Retention Tensile Force</b>	444.82 N   100 lbf
<b>Connector Retention Torque</b>	5.42 N-m   47.998 in lb
<b>Coupling Nut Proof Torque</b>	4.52 N-m   39.997 in lb
<b>Coupling Nut Retention Force</b>	444.82 N   100 lbf
<b>Coupling Nut Retention Force Method</b>	MIL-C-39012C-3.23, 4.6.22
<b>Interface Durability</b>	500 cycles
<b>Interface Durability Method</b>	IEC 61169-4:9.5
<b>Mechanical Shock Test Method</b>	MIL-STD-202F, Method 213B, Test Condition C

## Environmental Specifications

<b>Operating Temperature</b>	-55 °C to +85 °C (-67 °F to +185 °F)
<b>Storage Temperature</b>	-55 °C to +85 °C (-67 °F to +185 °F)
<b>Attenuation, Ambient Temperature</b>	20 °C   68 °F
<b>Average Power, Ambient Temperature</b>	40 °C   104 °F
<b>Corrosion Test Method</b>	MIL-STD-1344A, Method 1001.1, Test Condition A
<b>Immersion Depth</b>	1 m
<b>Immersion Test Mating</b>	Unmated
<b>Immersion Test Method</b>	IEC 60529:2001, IP68
<b>Moisture Resistance Test Method</b>	MIL-STD-202F, Method 106F
<b>Thermal Shock Test Method</b>	MIL-STD-202F, Method 107G, Test Condition A-1, Low Temperature -55 °C
<b>Vibration Test Method</b>	MIL-STD-202F, Method 204D, Test Condition B
<b>Water Jetting Test Mating</b>	Unmated
<b>Water Jetting Test Method</b>	IEC 60529:2001, IP66

## Packaging and Weights

# F4NR-HC

---

**Weight, net**

160.9 g | 0.355 lb

## Regulatory Compliance/Certifications

**Agency**

**Classification**

CHINA-ROHS

Above maximum concentration value

ISO 9001:2015

Designed, manufactured and/or distributed under this quality management system

ROHS

Compliant/Exempted

UK-ROHS

Compliant/Exempted



### \* Footnotes

**Insertion Loss Coefficient, typical**  $0.05\sqrt{\text{freq}}$  (GHz) (not applicable for elliptical waveguide)

**Immersion Depth** Immersion at specified depth for 24 hours

# L4DR-PS

---

7-16 DIN Male Right Angle Positive Stop™ for 1/2 in LDF4-50A cable



## Product Classification

<b>Product Type</b>	Wireless and radiating connector
<b>Product Brand</b>	HELIAX®
<b>Product Series</b>	LDF4-50A
<b>Ordering Note</b>	CommScope® standard product (Global)

## General Specifications

<b>Body Style</b>	Right angle
<b>Cable Family</b>	LDF4-50A
<b>Inner Contact Attachment Method</b>	Captivated
<b>Inner Contact Plating</b>	Gold   Silver
<b>Interface</b>	7-16 DIN Male
<b>Mounting Angle</b>	Right angle
<b>Outer Contact Attachment Method</b>	Self-flare
<b>Outer Contact Plating</b>	Trimetal
<b>Pressurizable</b>	No

## Dimensions

<b>Height</b>	41.91 mm   1.65 in
<b>Width</b>	34.54 mm   1.36 in
<b>Length</b>	82.55 mm   3.25 in
<b>Right Angle Length</b>	18.29 mm   0.72 in
<b>Nominal Size</b>	1/2 in

## Outline Drawing

# L4DR-PS

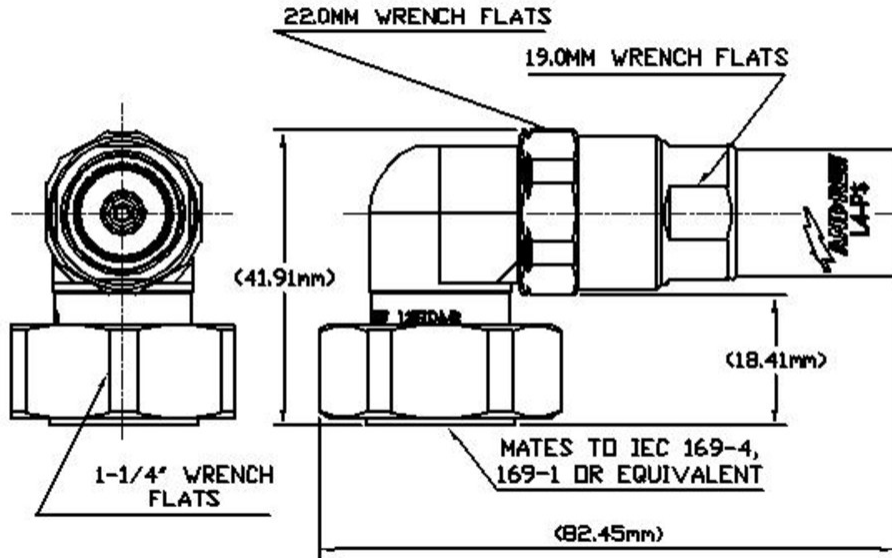

## Electrical Specifications

<b>3rd Order IMD at Frequency</b>	-120 dBm @ 910 MHz
<b>3rd Order IMD Test Method</b>	Two +43 dBm carriers
<b>Insertion Loss Coefficient, typical</b>	0.05
<b>Average Power at Frequency</b>	1.0 kW @ 900 MHz
<b>Cable Impedance</b>	50 ohm
<b>Connector Impedance</b>	50 ohm
<b>dc Test Voltage</b>	2500 V
<b>Inner Contact Resistance, maximum</b>	0.8 mOhm
<b>Insulation Resistance, minimum</b>	5000 MOhm
<b>Operating Frequency Band</b>	0 – 7500 MHz
<b>Outer Contact Resistance, maximum</b>	1.5 mOhm
<b>Peak Power, maximum</b>	15.6 kW
<b>RF Operating Voltage, maximum (vrms)</b>	884 V
<b>Shielding Effectiveness</b>	-110 dB

## VSWR/Return Loss

<b>Frequency Band</b>	<b>VSWR</b>	<b>Return Loss (dB)</b>
<b>50–1000 MHz</b>	1.018	40.99

# L4DR-PS

---

<b>1000–1900 MHz</b>	1.03	36.61
<b>1900–2200 MHz</b>	1.058	31
<b>2200–2700 MHz</b>	1.07	29.42
<b>2700–3600 MHz</b>	1.09	27.32
<b>3600–6000 MHz</b>	1.19	21.24
<b>6000–8800 MHz</b>	1.67	12.01

## Mechanical Specifications

<b>Connector Retention Tensile Force</b>	889.64 N   200 lbf
<b>Connector Retention Torque</b>	5.42 N-m   47.998 in lb
<b>Coupling Nut Proof Torque</b>	24.86 N-m   220.003 in lb
<b>Coupling Nut Retention Force</b>	1,000.85 N   225 lbf
<b>Coupling Nut Retention Force Method</b>	MIL-C-39012C-3.25, 4.6.22
<b>Interface Durability</b>	500 cycles
<b>Interface Durability Method</b>	IEC 61169-4:9.5
<b>Mechanical Shock Test Method</b>	MIL-STD-202F, Method 213B, Test Condition C

## Environmental Specifications

<b>Operating Temperature</b>	-55 °C to +85 °C (-67 °F to +185 °F)
<b>Storage Temperature</b>	-55 °C to +85 °C (-67 °F to +185 °F)
<b>Attenuation, Ambient Temperature</b>	20 °C   68 °F
<b>Average Power, Ambient Temperature</b>	40 °C   104 °F
<b>Corrosion Test Method</b>	MIL-STD-1344A, Method 1001.1, Test Condition A
<b>Immersion Depth</b>	1 m
<b>Immersion Test Mating</b>	Unmated
<b>Immersion Test Method</b>	IEC 60529:2001, IP68
<b>Moisture Resistance Test Method</b>	MIL-STD-202F, Method 106F
<b>Thermal Shock Test Method</b>	MIL-STD-202F, Method 107G, Test Condition A-1, Low Temperature -55 °C
<b>Vibration Test Method</b>	MIL-STD-202F, Method 204D, Test Condition B
<b>Water Jetting Test Mating</b>	Unmated
<b>Water Jetting Test Method</b>	IEC 60529:2001, IP66

## Packaging and Weights

# L4DR-PS

---

**Weight, net**

166.9 g | 0.368 lb

## Regulatory Compliance/Certifications

**Agency**

**Classification**

CHINA-ROHS

Above maximum concentration value

ISO 9001:2015

Designed, manufactured and/or distributed under this quality management system

ROHS

Compliant/Exempted

UK-ROHS

Compliant/Exempted



### \* Footnotes

**Insertion Loss Coefficient, typical** 0.05√freq (GHz) (not applicable for elliptical waveguide)

**Immersion Depth** Immersion at specified depth for 24 hours

# L4NR-PS

Type N Male Right Angle Positive Stop™ for 1/2 in LDF4-50A cable



## Product Classification

<b>Product Type</b>	Wireless and radiating connector
<b>Product Brand</b>	HELIAX®   Positive Stop™
<b>Product Series</b>	LDF4-50A
<b>Ordering Note</b>	CommScope® standard product (Global)

## General Specifications

<b>Body Style</b>	Right angle
<b>Cable Family</b>	LDF4-50A
<b>Inner Contact Attachment Method</b>	Captivated
<b>Inner Contact Plating</b>	Gold   Silver
<b>Interface</b>	N Male
<b>Mounting Angle</b>	Right angle
<b>Outer Contact Attachment Method</b>	Self-flare
<b>Outer Contact Plating</b>	Trimetal
<b>Pressurizable</b>	No

## Dimensions

<b>Height</b>	45.97 mm   1.81 in
<b>Width</b>	23.62 mm   0.93 in
<b>Length</b>	75.18 mm   2.96 in
<b>Right Angle Length</b>	22.61 mm   0.89 in
<b>Nominal Size</b>	1/2 in

## Outline Drawing

# L4NR-PS

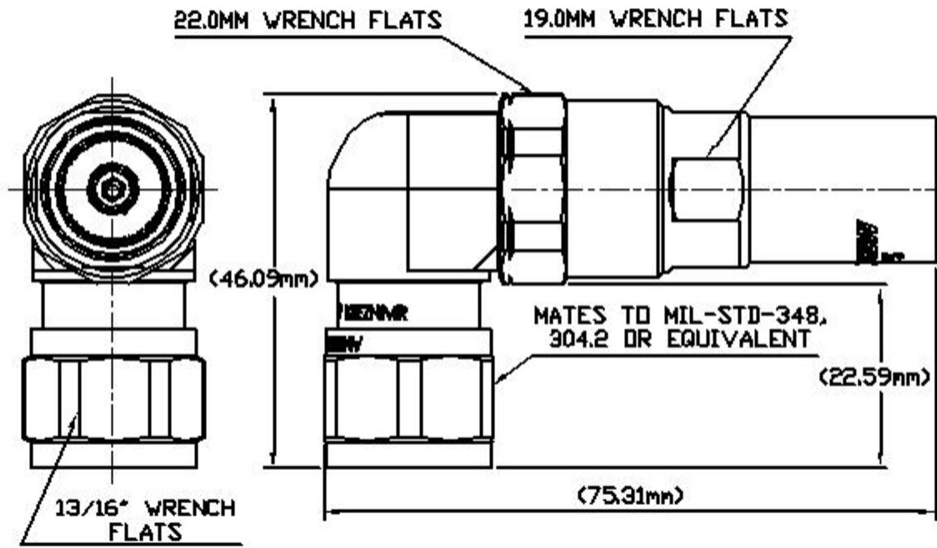

## Electrical Specifications

<b>3rd Order IMD at Frequency</b>	-116 dBm @ 910 MHz
<b>3rd Order IMD Test Method</b>	Two +43 dBm carriers
<b>Insertion Loss Coefficient, typical</b>	0.05
<b>Average Power at Frequency</b>	0.6 kW @ 900 MHz
<b>Cable Impedance</b>	50 ohm
<b>Connector Impedance</b>	50 ohm
<b>dc Test Voltage</b>	2000 V
<b>Inner Contact Resistance, maximum</b>	2 mOhm
<b>Insulation Resistance, minimum</b>	5000 MOhm
<b>Operating Frequency Band</b>	0 – 8800 MHz
<b>Outer Contact Resistance, maximum</b>	0.3 mOhm
<b>Peak Power, maximum</b>	10 kW
<b>RF Operating Voltage, maximum (vrms)</b>	707 V
<b>Shielding Effectiveness</b>	-110 dB

## VSWR/Return Loss

<b>Frequency Band</b>	<b>VSWR</b>	<b>Return Loss (dB)</b>
<b>50–1000 MHz</b>	1.02	40.09



# L4NR-PS

---

<b>1000–1900 MHz</b>	1.04	34.16
<b>1900–2200 MHz</b>	1.05	32.26
<b>2200–2700 MHz</b>	1.08	28.3
<b>2700–3600 MHz</b>	1.1	26.45
<b>3600–6000 MHz</b>	1.119	25.01
<b>6000–8800 MHz</b>	1.29	-18

## Mechanical Specifications

<b>Connector Retention Tensile Force</b>	889.64 N   200 lbf
<b>Connector Retention Torque</b>	5.42 N-m   47.998 in lb
<b>Coupling Nut Proof Torque</b>	4.52 N-m   39.997 in lb
<b>Coupling Nut Retention Force</b>	444.82 N   100 lbf
<b>Coupling Nut Retention Force Method</b>	MIL-C-39012C-3.23, 4.6.22
<b>Interface Durability</b>	500 cycles
<b>Interface Durability Method</b>	IEC 61169-4:9.5
<b>Mechanical Shock Test Method</b>	MIL-STD-202F, Method 213B, Test Condition C

## Environmental Specifications

<b>Operating Temperature</b>	-55 °C to +85 °C (-67 °F to +185 °F)
<b>Storage Temperature</b>	-55 °C to +85 °C (-67 °F to +185 °F)
<b>Attenuation, Ambient Temperature</b>	20 °C   68 °F
<b>Average Power, Ambient Temperature</b>	40 °C   104 °F
<b>Corrosion Test Method</b>	MIL-STD-1344A, Method 1001.1, Test Condition A
<b>Immersion Depth</b>	1 m
<b>Immersion Test Mating</b>	Unmated
<b>Immersion Test Method</b>	IEC 60529:2001, IP68
<b>Moisture Resistance Test Method</b>	MIL-STD-202F, Method 106F
<b>Thermal Shock Test Method</b>	MIL-STD-202F, Method 107G, Test Condition A-1, Low Temperature -55 °C
<b>Vibration Test Method</b>	MIL-STD-202F, Method 204D, Test Condition B
<b>Water Jetting Test Mating</b>	Unmated
<b>Water Jetting Test Method</b>	IEC 60529:2001, IP66

## Packaging and Weights

# L4NR-PS

---

**Weight, net**

133.1 g | 0.293 lb

## Regulatory Compliance/Certifications

**Agency**

**Classification**

ISO 9001:2015

Designed, manufactured and/or distributed under this quality management system

ROHS

Compliant

UK-ROHS

Compliant

## \* Footnotes

**Insertion Loss Coefficient, typical**  $0.05\sqrt{\text{freq}} \text{ (GHz)}$  (not applicable for elliptical waveguide)

**Immersion Depth** Immersion at specified depth for 24 hours