

APG-BNFM-350



Arrestor Plus® Gas Tube Surge Arrestor (350 V), 45–2170 MHz, with interface types N Female Bulkhead and N Male

Product Classification

Product Type	Gas tube
Product Brand	Arrestor Plus®
Ordering Note	CommScope® non-standard product

General Specifications

Device Type	dc Pass
Body Style	Bulkhead
Inner Contact Plating	Gold
Interface	N Female Bulkhead
Interface 2	N Male
Outer Contact Plating	Silver
Pressurizable	No

Dimensions

Height	26 mm 1.024 in
Width	26 mm 1.024 in
Length	61.7 mm 2.429 in

Outline Drawing

APG-BNFNM-350

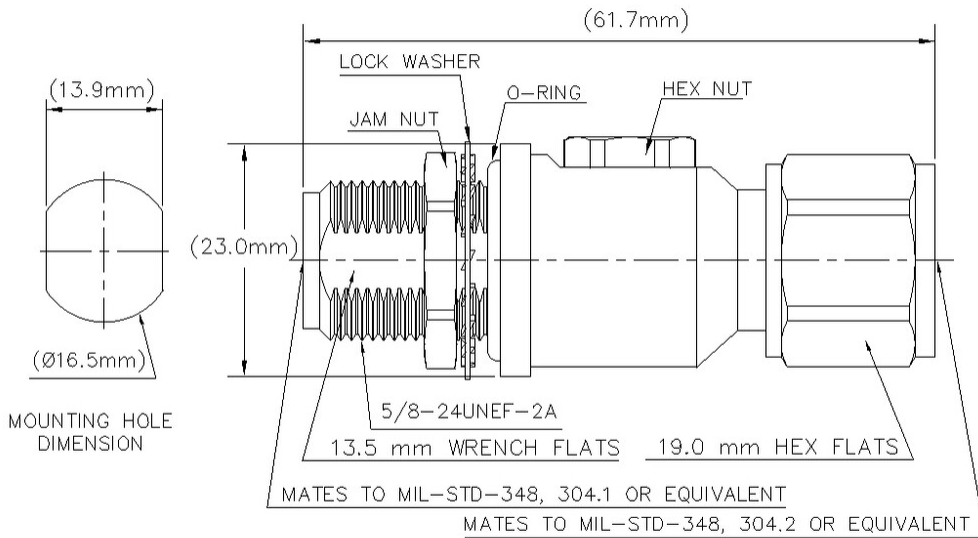

Electrical Specifications

Insertion Loss, typical	0.2 dB
Average Power	400 W
Connector Impedance	50 ohm
Gas Tube Voltage	350 V
Lightning Surge Current	20 kA
Lightning Surge Current Waveform	8/20 waveform
Operating Frequency Band	1000 – 2000 MHz 2000 – 2170 MHz 45 – 1000 MHz

VSWR/Return Loss

Frequency Band	VSWR	Return Loss (dB)
45–1000 MHz	1.094	27
1000–2000 MHz	1.094	27
2000–2170 MHz	1.173	22

Mechanical Specifications

Attachment Durability	25 cycles
------------------------------	-----------

APG-BNFM-350

Coupling Nut Proof Torque	4.52 N-m 40.005 in lb
Coupling Nut Retention Force	444.822 N 100 lbf
Coupling Nut Retention Force Method	MIL-C-39012C-3.25, 4.6.22
Interface Durability	500 cycles
Interface Durability Method	IEC 61169-16:9.5
Mechanical Shock Test Method	MIL-STD-202F, Method 213B, Test Condition C

Environmental Specifications

Operating Temperature	-40 °C to +100 °C (-40 °F to +212 °F)
Storage Temperature	-40 °C to +100 °C (-40 °F to +212 °F)
Attenuation, Ambient Temperature	20 °C 68 °F
Average Power, Ambient Temperature	40 °C 104 °F
Corrosion Test Method	MIL-STD-202, Method 101, Test Condition B
Immersion Depth	1 m
Immersion Test Mating	Mated
Immersion Test Method	IEC 60529:2001, IP68
Moisture Resistance Test Method	MIL-STD-202, Method 106
Thermal Shock Test Method	MIL-STD-202, Method 107, Test Condition A-1, Low Temperature -55 °C
Vibration Test Method	GR 2846-CORE
Water Jetting Test Mating	Mated
Water Jetting Test Method	IEC 60529:2001, IP66

Packaging and Weights

Weight, net	0.097 kg 0.214 lb
--------------------	---------------------

Regulatory Compliance/Certifications

Agency	Classification
CHINA-ROHS	Below maximum concentration value
ISO 9001:2015	Designed, manufactured and/or distributed under this quality management system
REACH-SVHC	Compliant as per SVHC revision on www.commscope.com/ProductCompliance
ROHS	Compliant
UK-ROHS	Compliant



