

Fiber outdoor drop cable, LightScope ZWP® Self-Supporting Non-Armored Figure-8, Singlemode G.652.D and G.657.A1, 6 fiber Arid Core construction with 0.109 in messenger, Gel-filled, central loose tube, Feet jacket marking, Black jacket color

- *Product complies with the Build America, Buy America Act (BABAA) requirements of the Infrastructure Investment and Jobs Act of 2021 (Pub. L. 117- 58, §§ 70901-70953), or is the subject of a waiver approved by the Secretary of Commerce or designee. Compliance requirements and waiver applicability vary based on government funding program. Check the laws and regulations for your specific program.

Product Classification

Regional Availability	Asia Australia/New Zealand EMEA Latin America North America
Portfolio	CommScope®
Product Type	Fiber drop cable
Product Series	M-MN
Government Funding	Build America Buy America (BABA) compliant*

General Specifications

Cable Type	Central loose tube
Construction Type	Non-armored
Subunit Type	Gel-filled
Jacket Color	Black
Jacket Marking	Feet
Subunit, quantity	1
Fibers per Subunit, quantity	6
Total Fiber Count	6

Dimensions

Height Over Jacket	10.7 mm 0.421 in
Buffer Tube/Subunit Diameter	2.5 mm 0.098 in
Diameter Over Jacket	5.1 mm 0.201 in
Diameter Over Messenger Jacket	4.3 mm 0.169 in

Representative Image

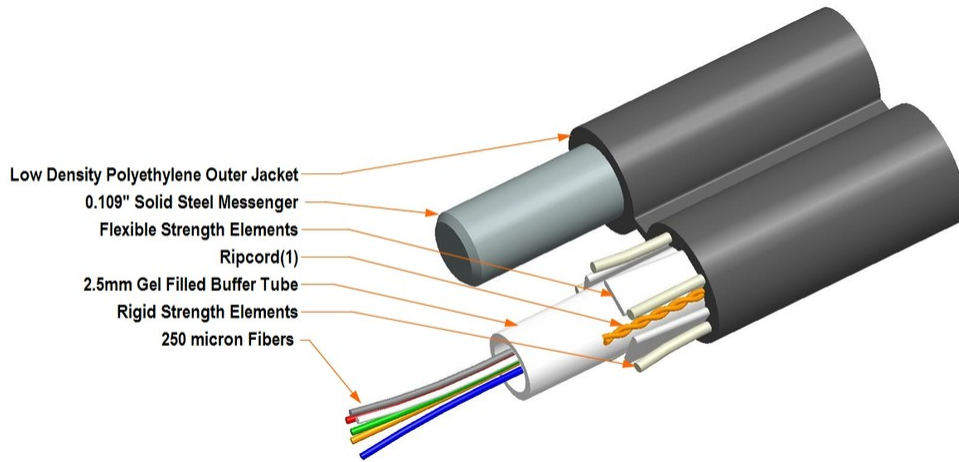

Material Specifications

Jacket Material PE

Mechanical Specifications

Minimum Bend Radius, loaded	77 mm 3.031 in
Minimum Bend Radius, unloaded	51 mm 2.008 in
Tensile Load, long term, maximum	400 N 89.924 lbf
Tensile Load, short term, maximum	1334 N 299.895 lbf
Compression	10 N/mm 57.101 lb/in
Compression Test Method	FOTP-41 IEC 60794-1 E3
Flex	35 cycles
Flex Test Method	FOTP-104 IEC 60794-1 E6
Impact	1.47 N-m 13.011 in lb
Impact Test Method	FOTP-25 IEC 60794-1 E4
Strain	See long and short term tensile loads
Strain Test Method	FOTP-33 IEC 60794-1 E1
Twist	10 cycles
Twist Test Method	FOTP-85 IEC 60794-1 E7
Vertical Rise, maximum	529 m 1,735.564 ft

Optical Specifications

Fiber Type G.652.D and G.657.A1 | G.652.D and G.657.A1

Environmental Specifications

Installation temperature	-30 °C to +70 °C (-22 °F to +158 °F)
Operating Temperature	-40 °C to +70 °C (-40 °F to +158 °F)
Storage Temperature	-40 °C to +75 °C (-40 °F to +167 °F)
Cable Qualification Standards	ANSI/ICEA S-110-717
Environmental Space	Aerial, self-support
Jacket UV Resistance	UV stabilized
Water Penetration	24 h
Water Penetration Test Method	FOTP-82 IEC 60794-1 F5

Environmental Test Specifications

Cable Freeze	-2 °C 28.4 °F
Cable Freeze Test Method	FOTP-98 IEC 60794-1 F15
Drip	70 °C 158 °F
Drip Test Method	FOTP-81 IEC 60794-1 E14
Heat Age	-40 °C to +85 °C (-40 °F to +185 °F)
Heat Age Test Method	IEC 60794-1 F9
Low High Bend	-30 °C to +60 °C (-22 °F to +140 °F)
Low High Bend Test Method	FOTP-37 IEC 60794-1 E11
Temperature Cycle	-40 °C to +70 °C (-40 °F to +158 °F)
Temperature Cycle Test Method	FOTP-3 IEC 60794-1 F1

Packaging and Weights

Cable weight	77 kg/km 51.742 lb/kft
---------------------	--------------------------

Regulatory Compliance/Certifications

Agency	Classification
ISO 9001:2015	Designed, manufactured and/or distributed under this quality management system



Included Products

DB-8W-LT

- LightScope ZWP® Singlemode
Fiber

* Footnotes

Operating Temperature Specification applicable to non-terminated bulk fiber cable

DB-8W-LT

LightScope ZWP® Singlemode Fiber



Product Classification

Portfolio	CommScope®
Product Type	Optical fiber

General Specifications

Cladding Diameter	125 µm
Cladding Diameter Tolerance	±0.7 µm
Cladding Non-Circularity, maximum	0.7 %
Coating Diameter (Colored)	249 µm
Coating Diameter (Uncolored)	242 µm
Coating Diameter Tolerance (Colored)	±13 µm
Coating Diameter Tolerance (Uncolored)	±5 µm
Coating/Cladding Concentricity Error, maximum	12 µm
Core Diameter	8.3 µm
Core/Clad Offset, maximum	0.5 µm
Proof Test	689.476 N/mm ² 100000 psi

Dimensions

Fiber Curl, minimum	4 m 13.123 ft
----------------------------	-----------------

Mechanical Specifications

Macrobending, 20 mm Ø mandrel, 1 turn	0.75 dB @ 1,550 nm 1.50 dB @ 1,625 nm
Macrobending, 30 mm Ø mandrel, 10 turns	0.25 dB @ 1,550 nm 1.00 dB @ 1,625 nm
Macrobending, 60 mm Ø mandrel, 100 turns	0.05 dB @ 1,550 nm 0.05 dB @ 1,625 nm
Coating Strip Force, maximum	8.9 N 2.001 lbf

DB-8W-LT

Coating Strip Force, minimum	1.3 N 0.292 lbf
Dynamic Fatigue Parameter, minimum	20

Optical Specifications

Cabled Cutoff Wavelength, maximum	1260 nm
Point Defects, maximum	0.1 dB
Zero Dispersion Slope, maximum	0.092 ps/[km-nm-nm]
Zero Dispersion Wavelength, maximum	1324 nm
Zero Dispersion Wavelength, minimum	1300 nm

Optical Specifications, Wavelength Specific

Attenuation, maximum	0.22 dB/km @ 1,550 nm 0.25 dB/km @ 1,490 nm 0.25 dB/km @ 1,625 nm 0.36 dB/km @ 1,310 nm 0.36 dB/km @ 1,385 nm
Attenuation, typical	0.19 dB/km @ 1,550 nm 0.33 dB/km @ 1,310 nm
Backscatter Coefficient	-79.6 dB @ 1,310 nm -82.1 dB @ 1,550 nm
Dispersion, maximum	18 ps(nm-km) at 1550 nm 3.5 ps(nm-km) from 1285 nm to 1330 nm at 1310 nm
Index of Refraction	1.467 @ 1,310 nm 1.467 @ 1,385 nm 1.468 @ 1,550 nm
Mode Field Diameter	10.4 μm @ 1,550 nm 9.2 μm @ 1,310 nm 9.6 μm @ 1,385 nm
Mode Field Diameter Tolerance	$\pm 0.4 \mu\text{m}$ @ 1310 nm $\pm 0.5 \mu\text{m}$ @ 1550 nm $\pm 0.6 \mu\text{m}$ @ 1385 nm
Polarization Mode Dispersion Link Design Value, maximum	0.04 ps/sqrt(km)
Standards Compliance	ITU-T G.652.D ITU-T G.657.A1

Environmental Specifications

Heat Aging, maximum	0.05 dB/km @ 85 °C
Temperature Dependence, maximum	0.05 dB/km
Temperature Humidity Cycling, maximum	0.05 dB/km
Water Immersion, maximum	0.05 dB/km @ 23 °C

Regulatory Compliance/Certifications

Agency	Classification
ISO 9001:2015	Designed, manufactured and/or distributed under this quality management system

DB-8W-LT



* Footnotes

- Temperature Dependence, maximum** Temperature dependence is conducted at -60 °C to +85 °C (-76 °F to +185 °F)
- Temperature Humidity Cycling, maximum** Temperature humidity cycling is conducted at -10 °C to +85 °C (+14 °F to +185 °F) up to 95% relative humidity