

Type L45Z

Splice Connector for LDF5-50 HELIAX® Coaxial Cable



Tools and Materials Required for Assembly

Wire brush	Wrenches: (2) 1-3/8"
Knife	Hacksaw, fine-toothed blade
File	

Read the Instructions
Thoroughly Before Assembly

1 Prepare Cables. End of each cable must be straight for at least 10" (254 mm). Cables are identified as cable A and cable B. Remove jacket to approximate dimension shown. Deburr sharp ends of outer conductors.

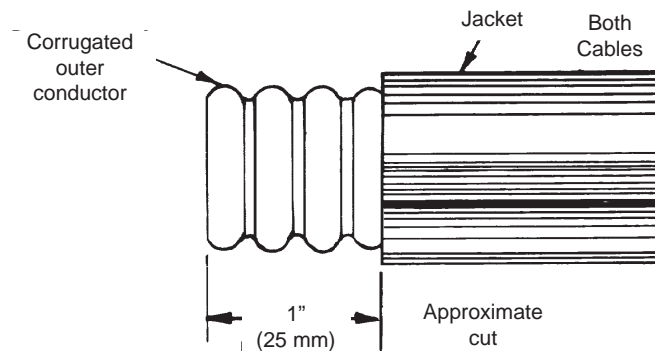

2 Make Second Jacketing Cut. Scribe line on ridge of exposed corrugated outer conductor of each cable. Remove jacket to dimension shown, using straight-edged piece of heavy paper around each cable to guide cut.

Cable A = 1-1/2" (38 mm)
Cable B = 1-1/4" (32 mm)

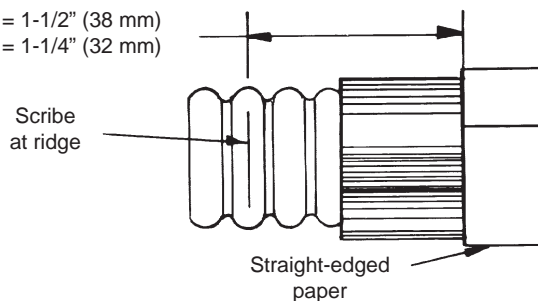

3 Add Outer Body and Gaskets. Slip outer body on cable B with internal threads facing cut end of cable. (Refer to illustration in Step 7 for position of outer body on cable B). Add small thick O-ring gasket to second fully-exposed corrugation groove from jacket on cable A, and another to first fully-exposed groove on cable B. Apply thin coating of silicone grease to outer surfaces of gaskets and gasket lead chamfers in clamping nuts.

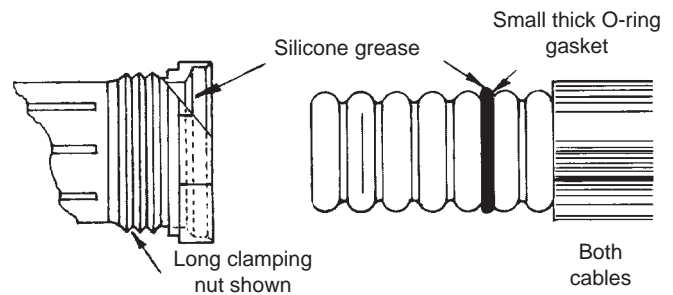

4 Add Clamping Nuts and Cut Cables. Push long clamping nut on cable A and short clamping nut on cable B. Use twisting motion to assure spring contacts snap into grooves. (Refer to cutaway view in Step 5.) To cut each cable, grip clamping nut with one hand and align edge with scribed line, then carefully saw cable flush with end of clamping nut.

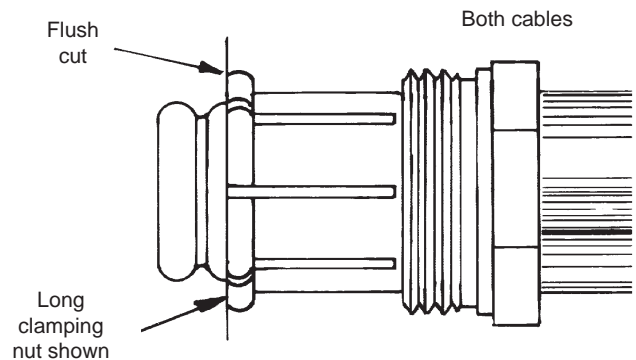

5 Separate Foam and Add Gaskets. Separate all foam completely from edge of each outer conductor to assure good electrical contact with flare ring. Use tip of knife, and work around entire circumference. Remove burrs from inside edges of outer and inner conductors with knife. Use wire brush to remove copper particles from foam. Place large thin O-ring gasket into gasket groove in each clamping nut.

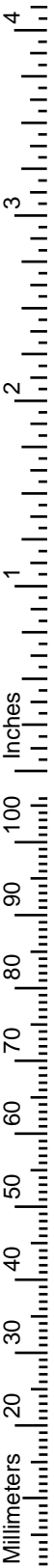
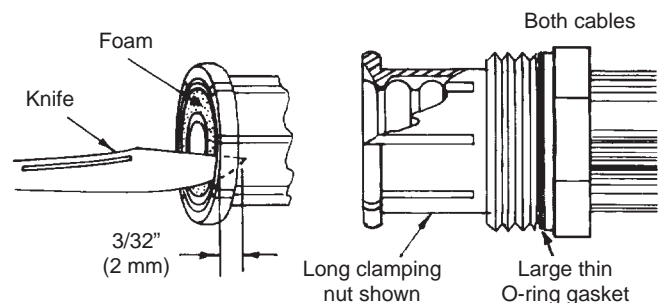

6 Install Inner Connector and Flare Ring. Slip flare ring over self-tapping inner connector, then place pin through hole in flare ring and inner connector. Use pin as handle to tap into inner conductors. Inner connector has left- and right-hand threads. Turn inner connector so it taps into inner conductors simultaneously. If tapping becomes difficult, back off inner connector after every few turns forward. Tap until cables are joined. Inner connector should butt against inner conductors, and flare ring should be tight against outer conductors. Tighten securely. Tapping operation can be checked by viewing through hole in either side of flare ring.

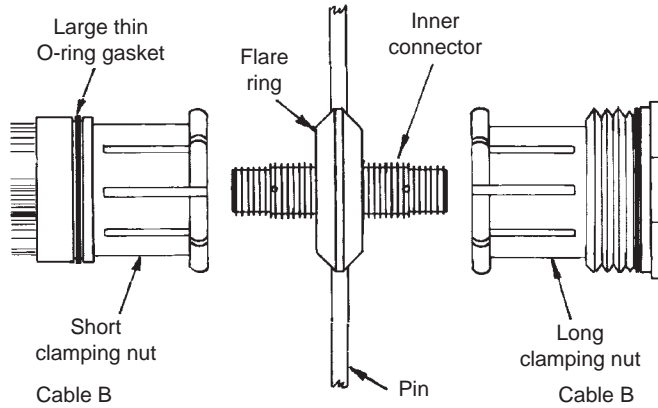

7 Install Outer Body. Add thin coating of silicone grease to outer surfaces of thin gaskets on clamping nuts. Slip outer body over short clamping nut and thread to long clamping nut. Tighten with wrenches. Turn outer body only; do not turn long clamping nut.

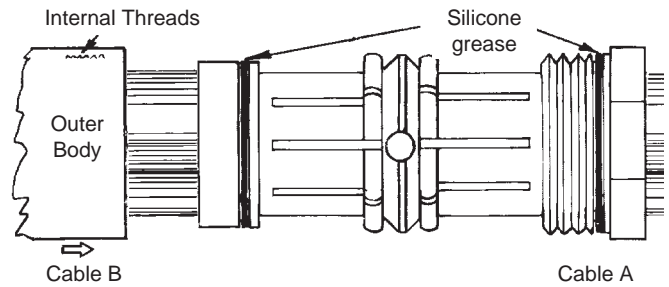

Notice

The installation, maintenance, or removal of antenna systems requires qualified, experienced personnel. Andrew installation instructions have been written for such personnel. Antenna systems should be inspected once a year by qualified personnel to verify proper installation, maintenance, and condition of equipment.

Andrew disclaims any liability or responsibility for the results of improper or unsafe installation practices.

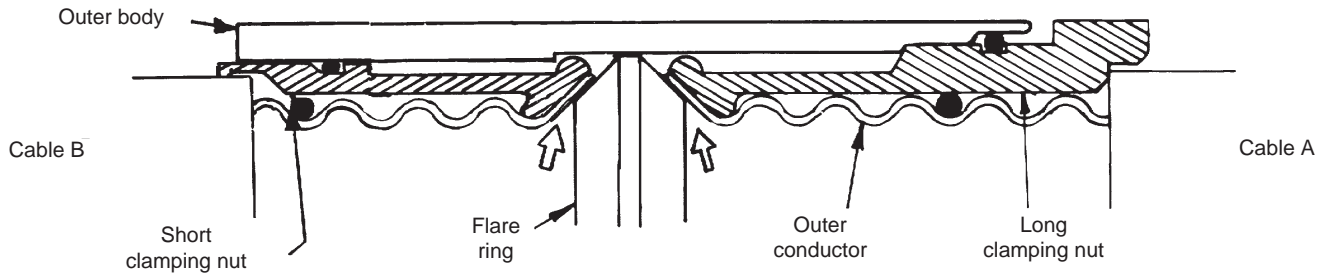

Andrew Corporation
10500 West 153rd Street
Orland Park, IL U.S.A. 60462

Telephone: 708-349-3300
FAX (U.S.A.): 1-800-349-5444
Internet: <http://www.andrew.com>

Customer Service, 24 hours: U.S.A. • Canada • Mexico: 1-800-255-1479
U.K.: 0800 250055 • Republic of Ireland: 1 800 535358
Other Europe: +44 1592 782612

Printed in U.S.A. 3/86

Copyright © 1986 by Andrew Corporation