

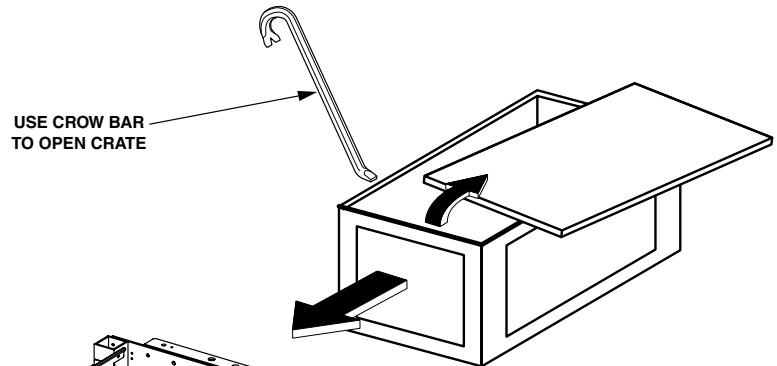

Next Generation Frame (NGF) (26- 30-inch) Installation Guide: Raised Floor/Concrete Floor

1 UNPACK RACK



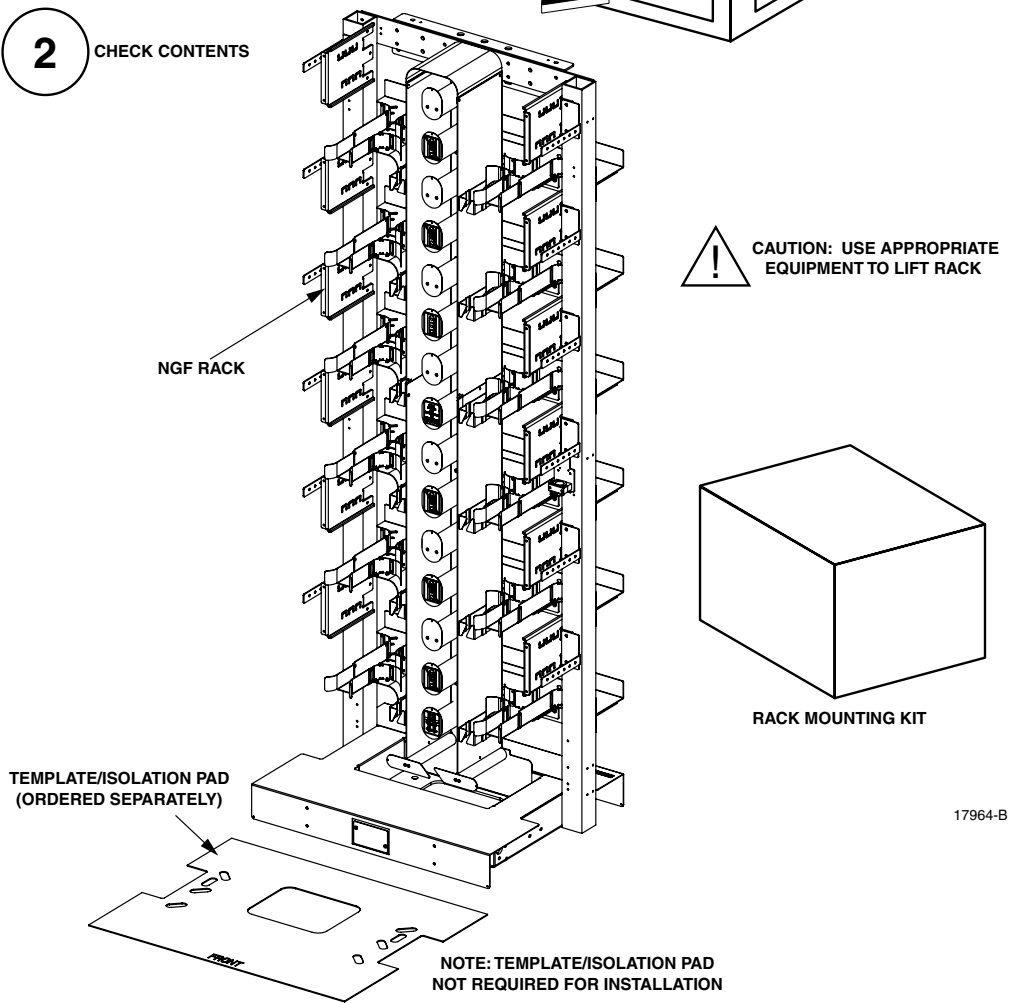

2 CHECK CONTENTS

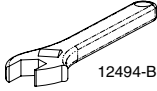
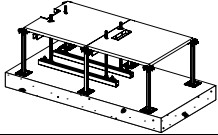
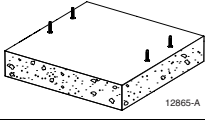

17964-B

Table 1. Tools Required

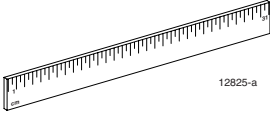
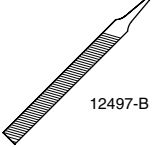
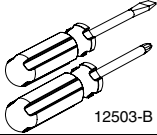
TOOL	PICTURE	RAISED FLOOR	CONCRETE FLOOR
Adjustable Wrenches (2) 0.25- to 1-inch (8mm to 25.4mm)	 <p>12494-B</p>	 <p>✓</p>	 <p>12865-A</p> <p>✓</p>
Crow Bar	 <p>12495-B</p>	<p>✓</p>	<p>✓</p>
Drill: with Metal and Concrete Drill Bits 0.25- to 1.0-inches (8mm to 25.4mm)	 <p>12496-B</p>	<p>✓</p>	<p>✓</p>
Ruler	 <p>12825-a</p>	<p>✓</p>	<p>✓</p>
File	 <p>12497-B</p>	<p>✓</p>	
Flat Tip (–) and Phillip (+) Screwdrivers (#1, #2, and #3)	 <p>12503-B</p>	<p>✓</p>	<p>✓</p>

continued

Table 1. Tools Required, continued

TOOLS REQUIRED (CONTINUED)	PICTURE	RAISED FLOOR	CONCRETE FLOOR
Hacksaw	 <p>12499-B</p>	 <p>✓</p>	 <p>12865-A</p>
Hammer	 <p>12500-B</p>	<p>✓</p>	<p>✓</p>
Jigsaw: Blades for Cutting Floor Tile and Metal	 <p>12501-B</p>	<p>✓</p>	
Level	 <p>12502-B</p>	<p>✓</p>	
Set of Open End/Box Wrenches 0.25- to 1.0-inches (8mm to 25.4mm)	 <p>12506-B</p>	<p>✓</p>	<p>✓</p>
Set of Sockets 0.25- to 1.0-inches (8mm to 25.4mm)	 <p>12504-B</p>	<p>✓</p>	<p>✓</p>
Vacuum	 <p>12505-B</p>	<p>✓</p>	<p>✓</p>

Table 2. Additional Materials Required

ITEM	DESCRIPTION		
Ground Cable 6 AWG (4.1mm)	Green with Yellow Stripe	✓	✓
Ground Lug	 <p style="text-align: center;">12498-B</p>	✓	✓
Crimping Tool	 <p style="text-align: center;">12824-A</p>	✓	✓

3 DETERMINE RACK LOCATION



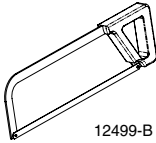
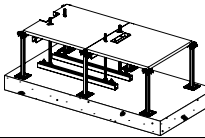
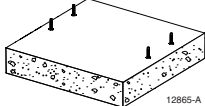
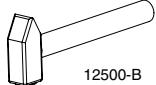
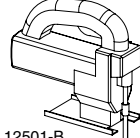
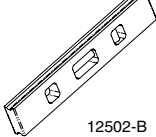
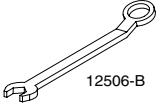
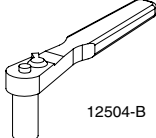
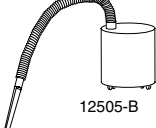
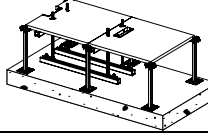
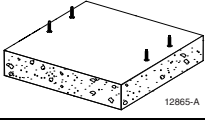
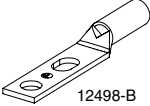
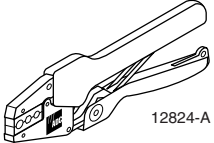
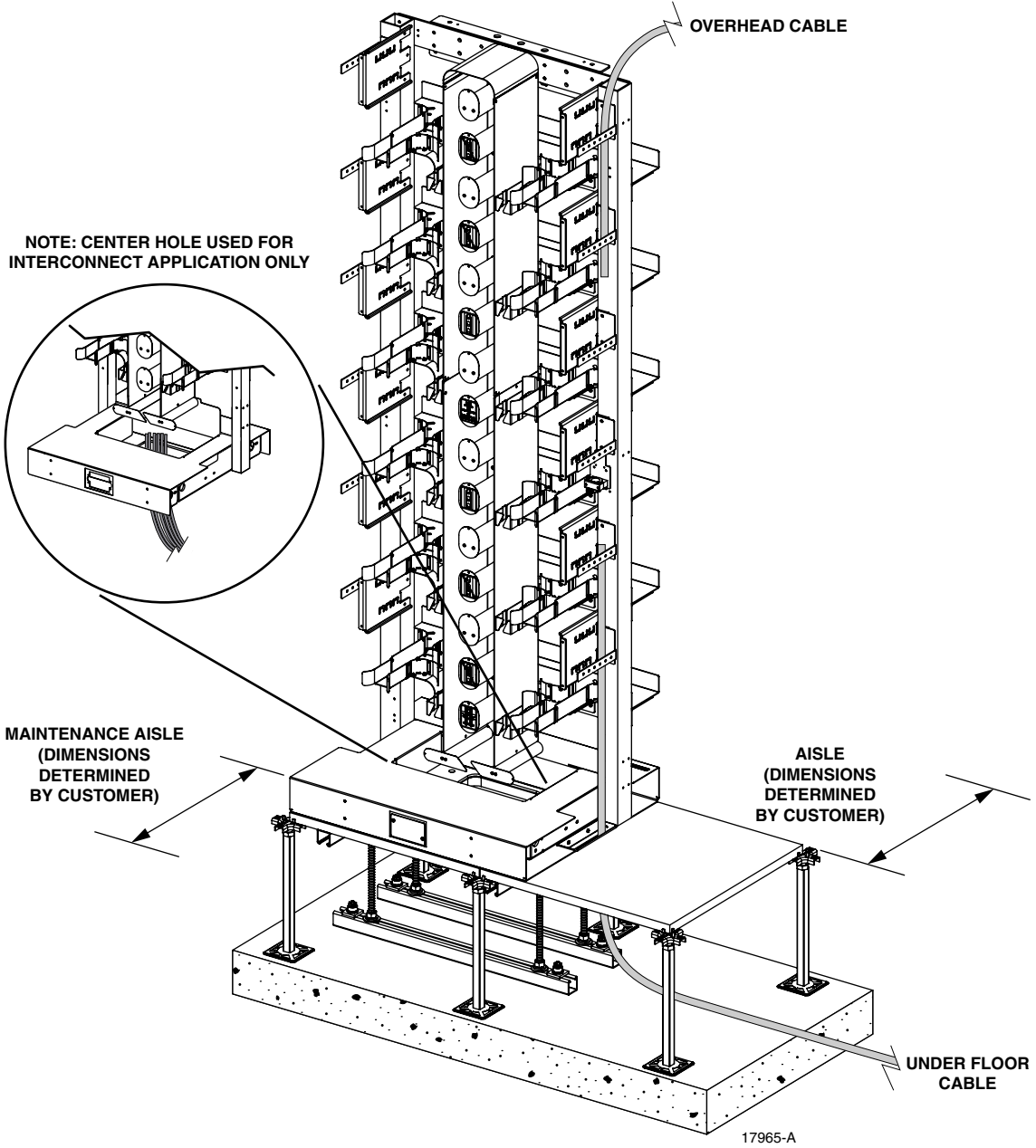
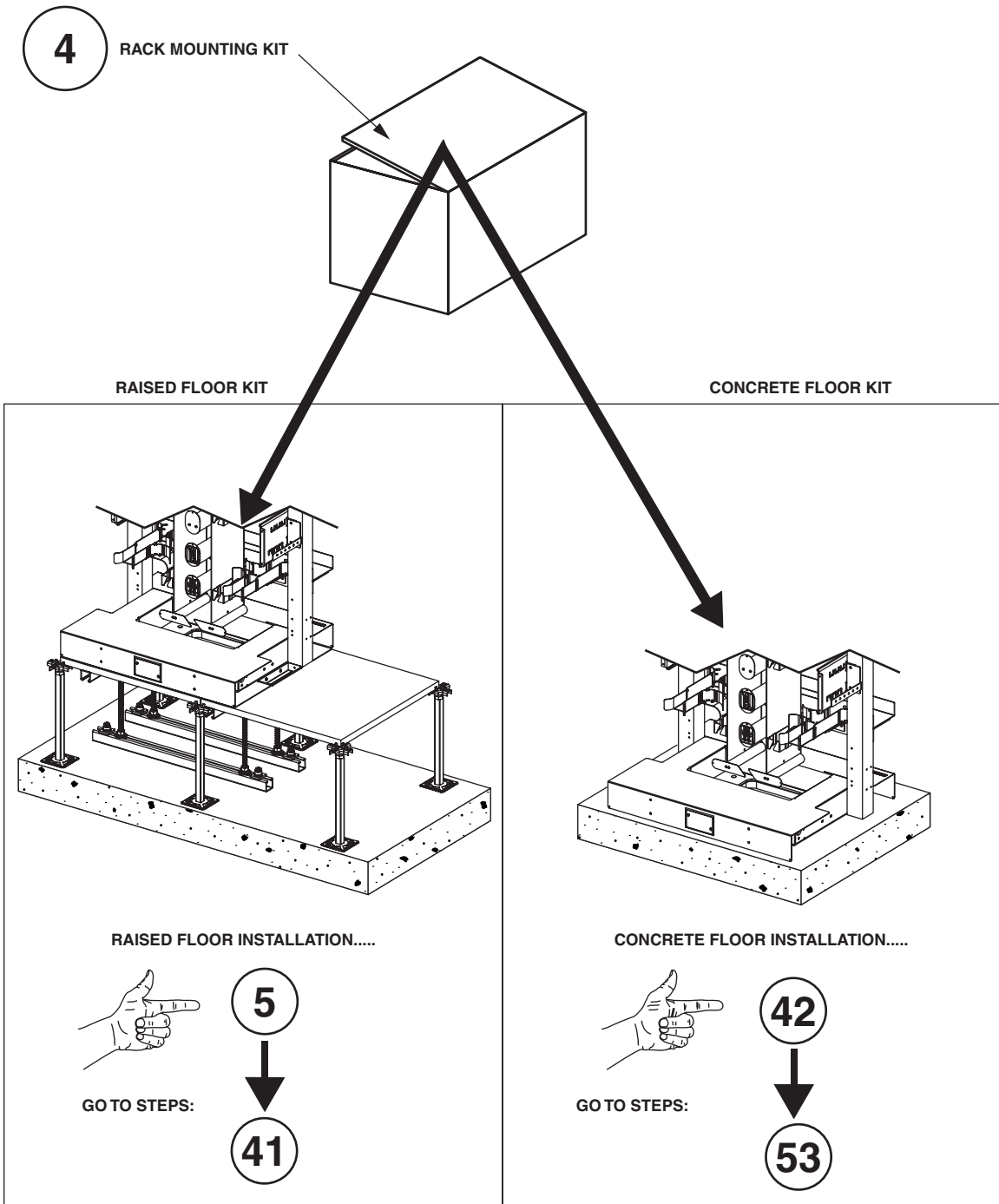

17966-A

RAISED FLOOR INSTALLATION

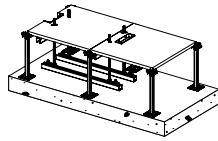

<p style="text-align: center;">5</p> <p>UNPACK ZONE 2/ZONE 4 RAISED FLOOR KIT</p>	
<p>THREADED ROD (4) 5/8"-11 x 30" LONG</p>	
<p>UNISTRUT 10 FEET LONG</p>	
<p>UNISTRUT NUT WITH SPRING (4)</p>	
<p>EXPANDING ANCHOR BOLT (4) (PROVIDED WITH RACK)</p>	
<p>HEX NUT HEAVY (12) 5/8"- x 11</p>	
<p>SPLIT LOCK WASHER (12) 5/8"</p>	
<p>FLAT WASHER (12) 5/8"</p>	

RAISED FLOOR INSTALLATION

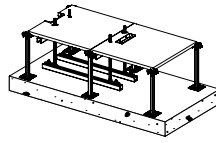

<p style="text-align: center;">5</p> <p>UNPACK ZONE 2/ZONE 4 RAISED FLOOR KIT (CONTINUED)</p>	
<p>HOLD DOWN PLATE (2) (PROVIDED WITH RACK)</p>	
<p>PLASTIC SHOULDER WASHER (4)</p>	
<p>EDGE PROTECTOR (1) 72"</p>	
<p>ANCHOR PLATE (4) (PROVIDED WITH RACK)</p>	

17968-C

RAISED FLOOR INSTALLATION

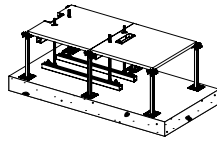

6 PLACE TEMPLATE/ISOLATION PAD ON FLOOR TILE(S)

NOTE: ONE RACK POSITION SHOWN FOR SIMPLICITY

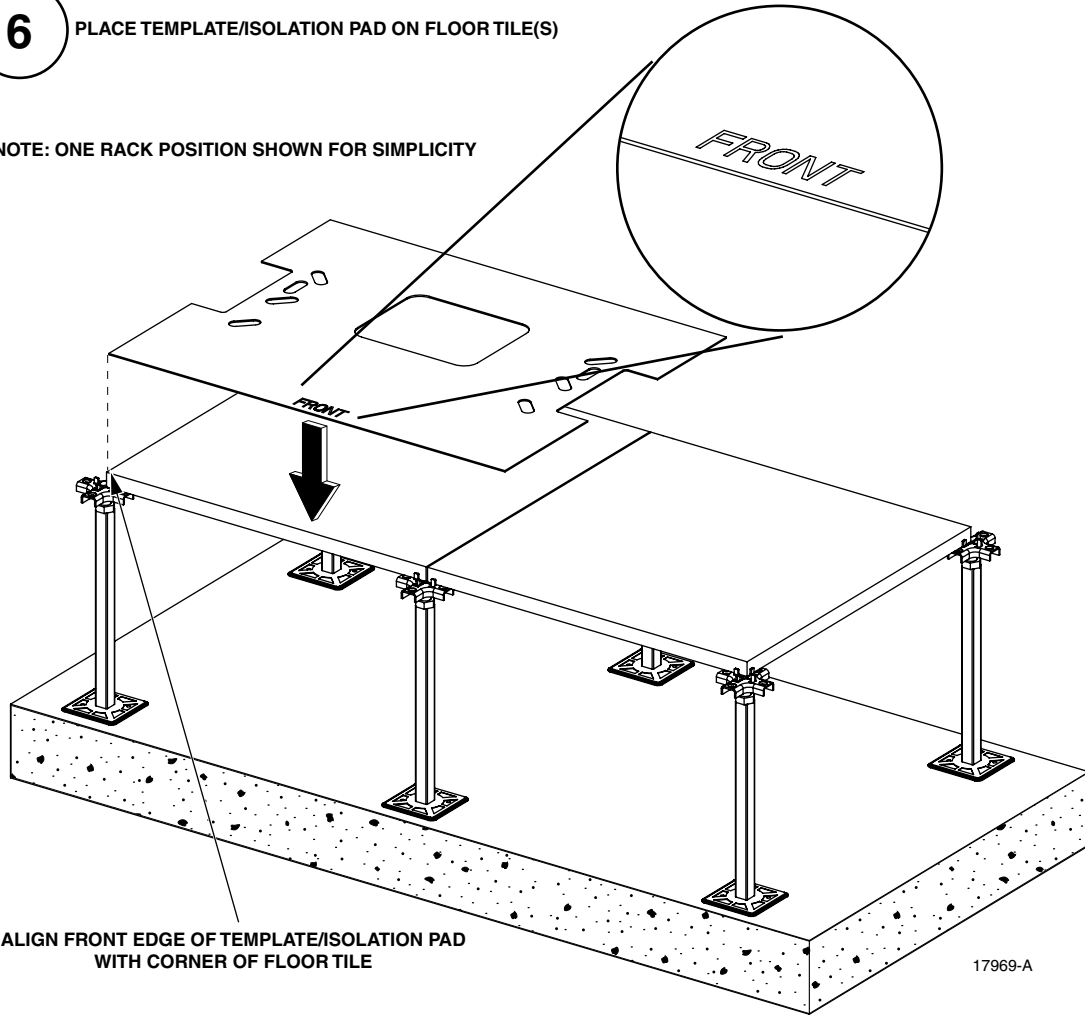

ALIGN FRONT EDGE OF TEMPLATE/ISOLATION PAD WITH CORNER OF FLOOR TILE

17969-A

RAISED FLOOR INSTALLATION

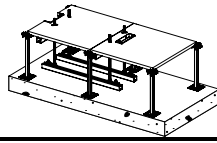

7

MARK TILE

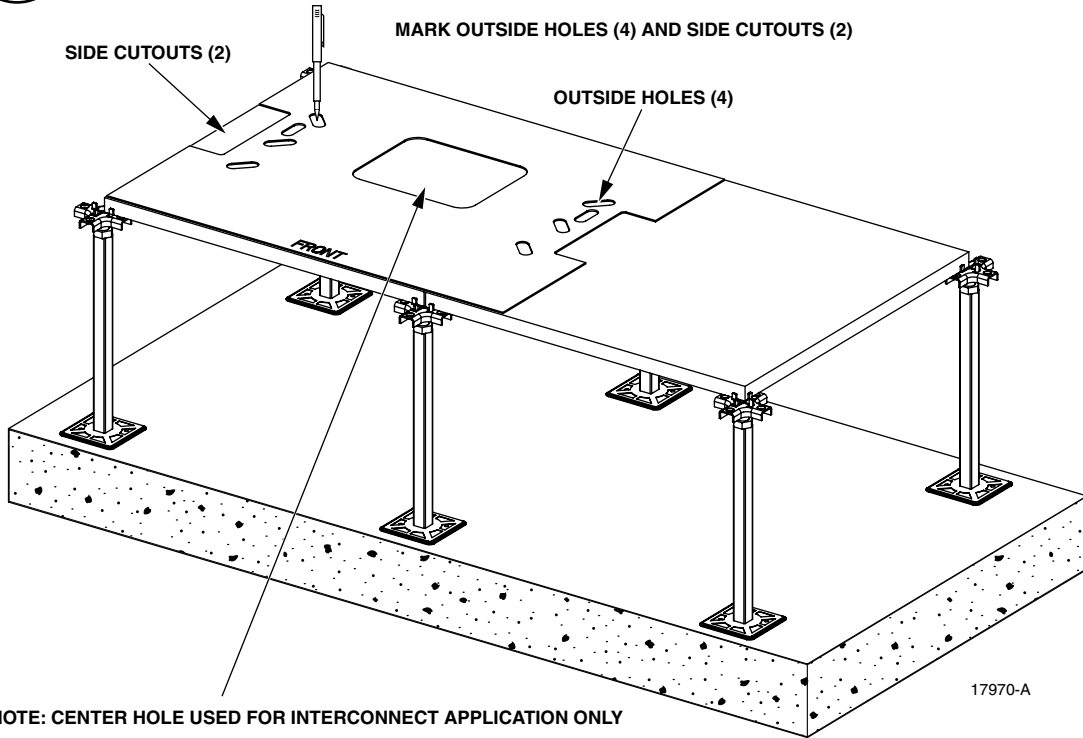

RAISED FLOOR INSTALLATION

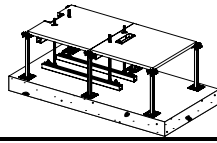

8

SET TEMPLATE/ISOLATION PAD ASIDE

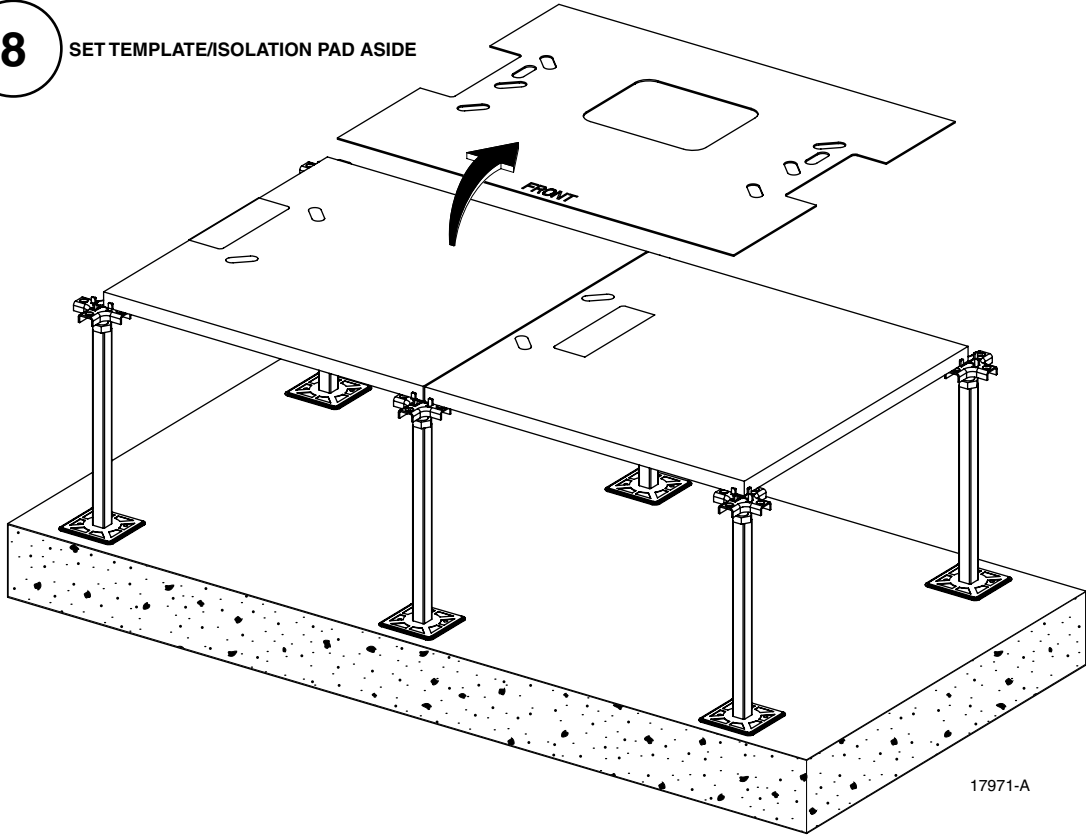

17971-A

RAISED FLOOR INSTALLATION

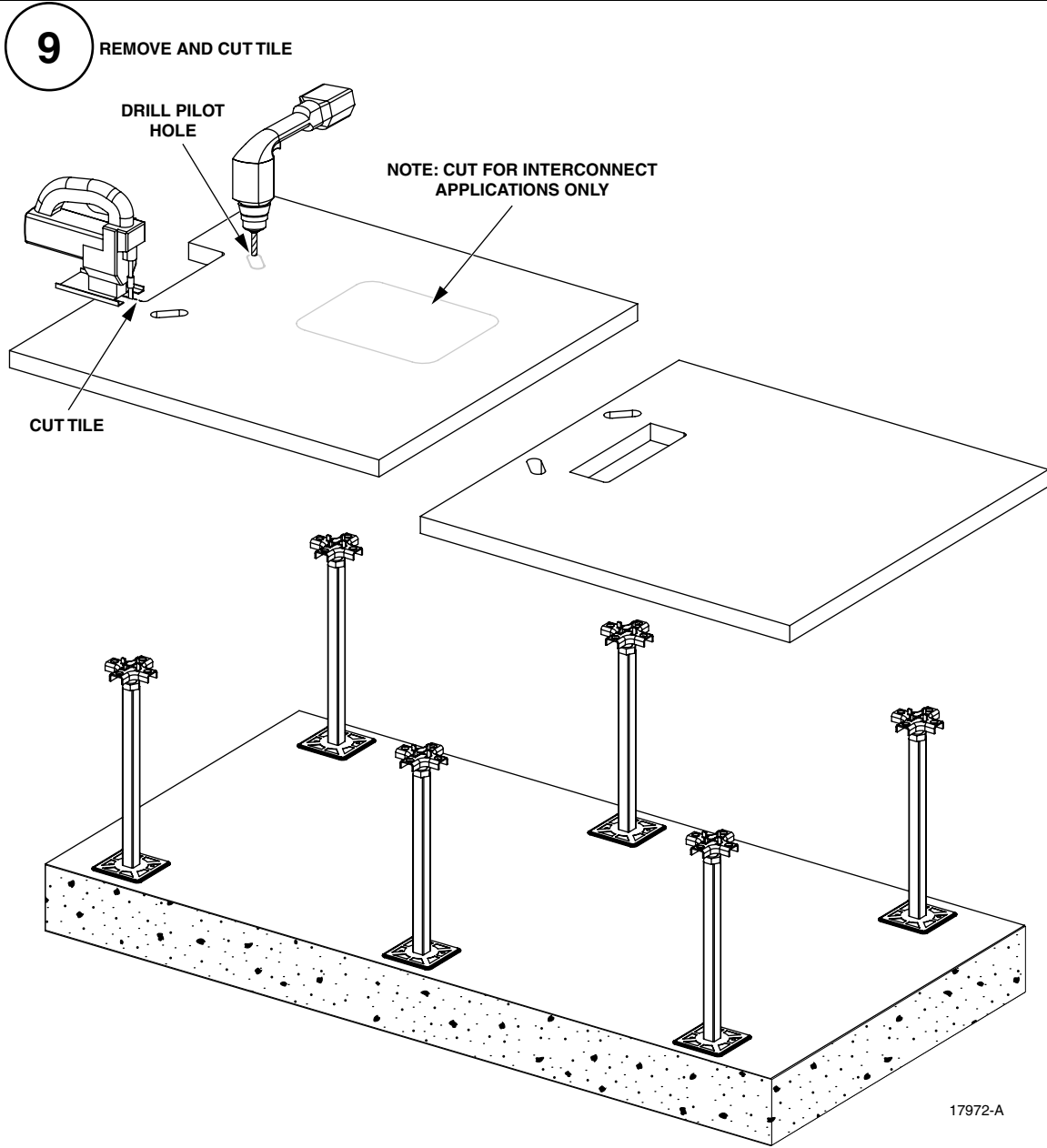
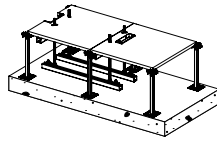

RAISED FLOOR INSTALLATION

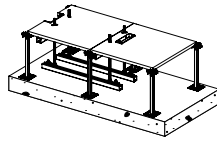

10 FILE ALL BOTTOM AND TOP EDGES

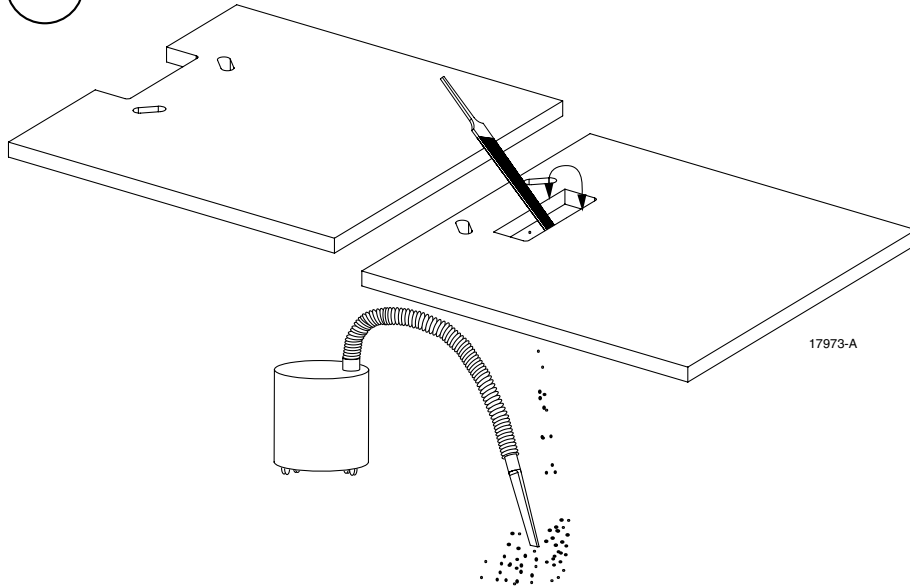

11 SET FLOOR TILES ON PEDESTALS

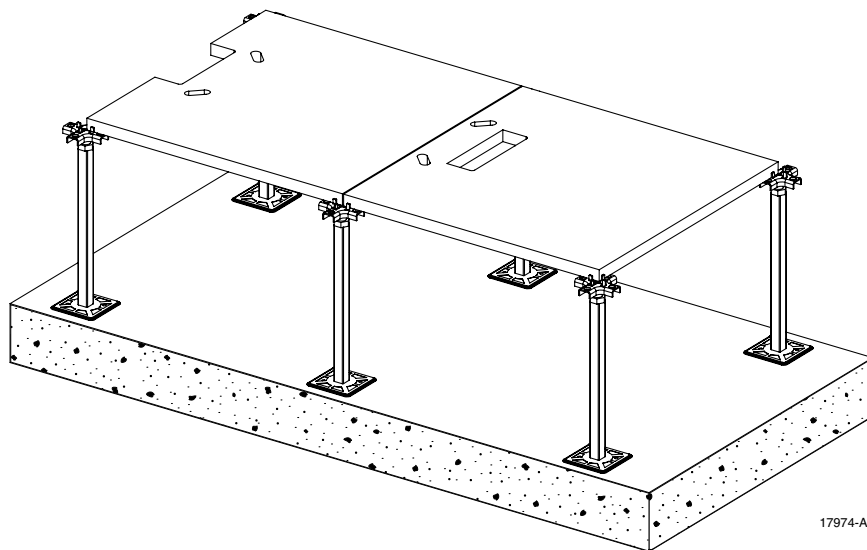

RAISED FLOOR INSTALLATION

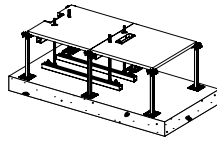

12 CUT THREADED ROD TO FLOOR HEIGHT $+1\text{-}5/8"$ ($\pm 3/8"$)

$1\text{-}5/8"$
($\pm 3/8"$)

NOTE: MEASURE FROM CONCRETE TO $1\text{-}5/8"$ ($\pm 3/8"$) ABOVE FLOOR TILE

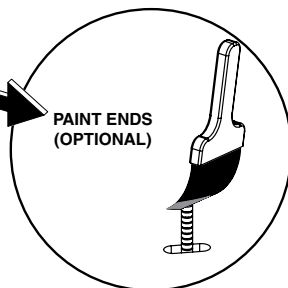
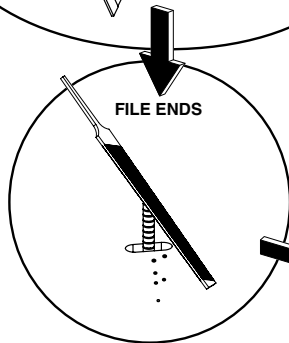
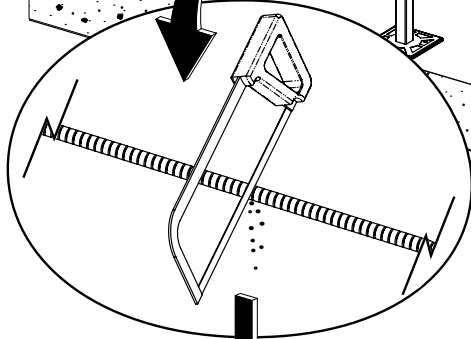
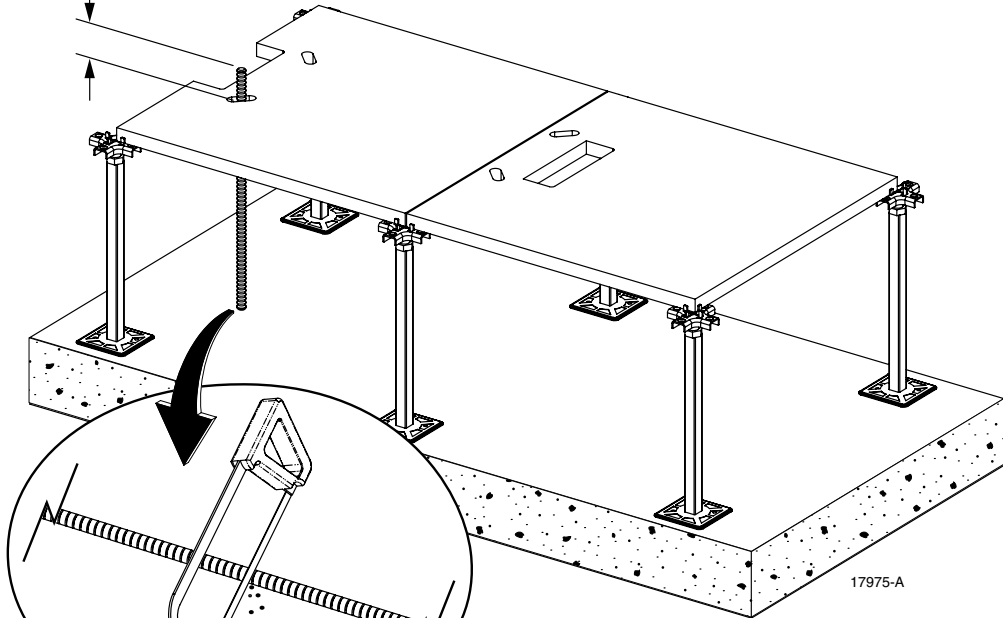

RAISED FLOOR INSTALLATION

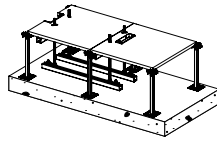

13 CUT UNISTRUT TO REQUIRED LENGTH

CUT UNISTRUT (4 PIECES)

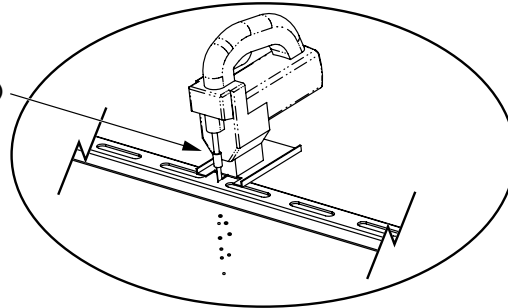

CUT TO
REQUIRED LENGTH

CUT TO
REQUIRED LENGTH

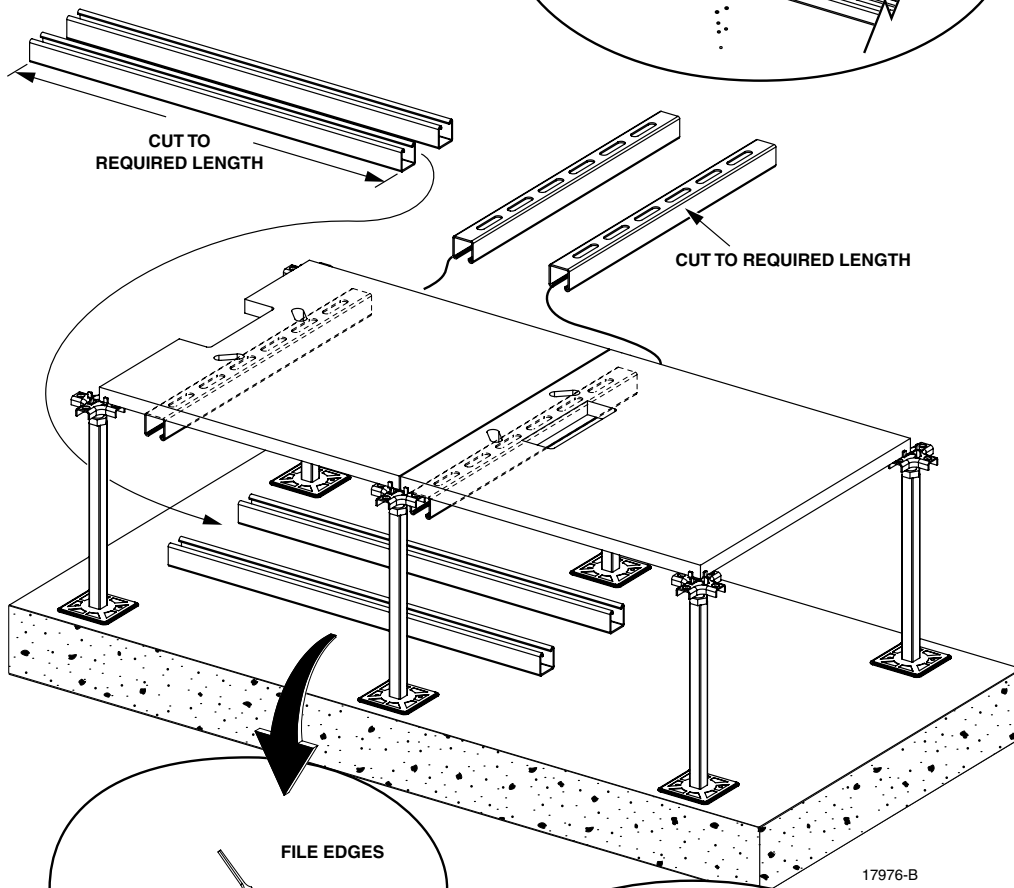

17976-B

FILE EDGES

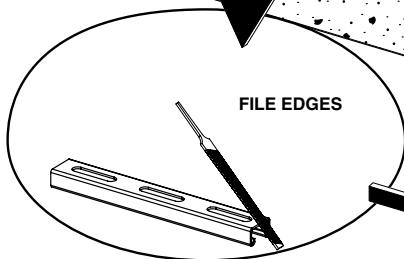

PAINT FILED EDGES
(OPTIONAL)

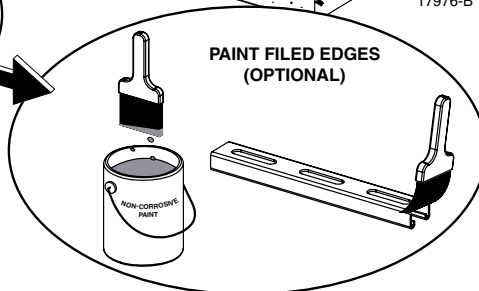

RAISED FLOOR INSTALLATION

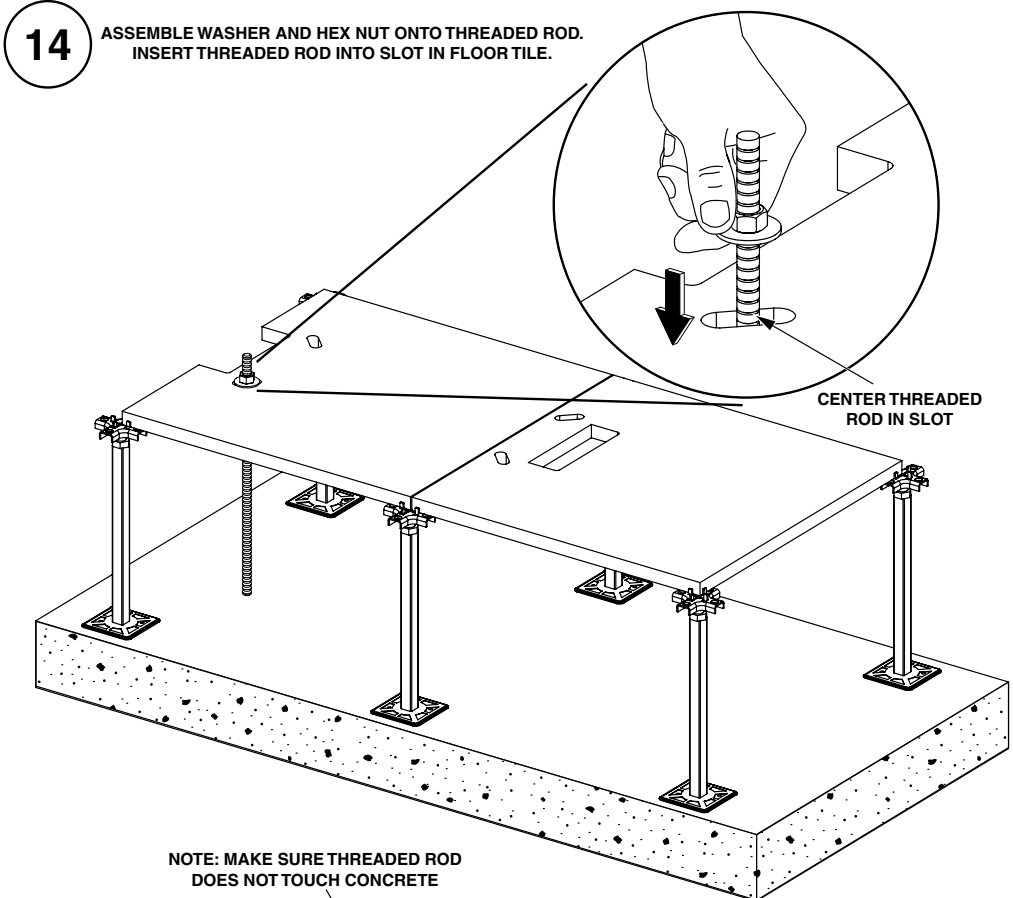
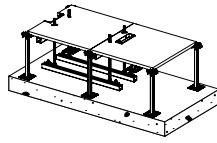

NOTE: MAKE SURE THREADED ROD DOES NOT TOUCH CONCRETE

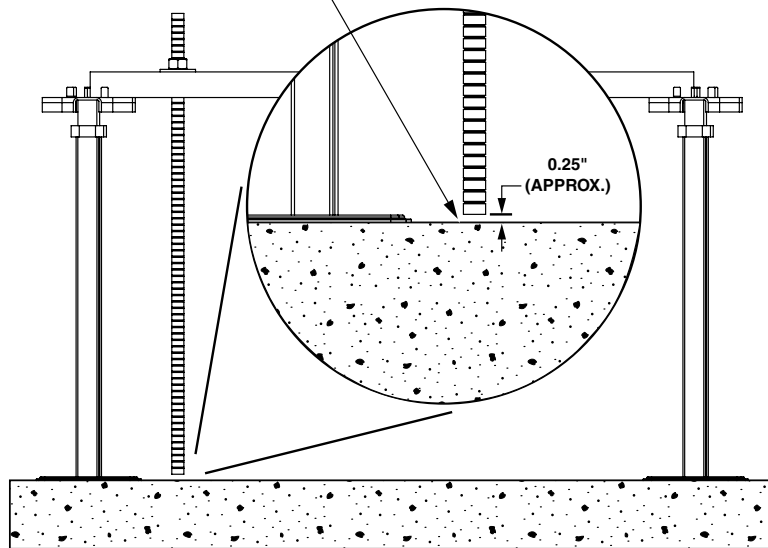

17977-A

RAISED FLOOR INSTALLATION

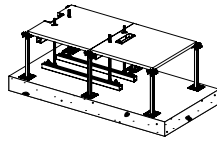

15 LEVEL THREADED RODS FROM FRONT TO BACK AND MARK CONCRETE

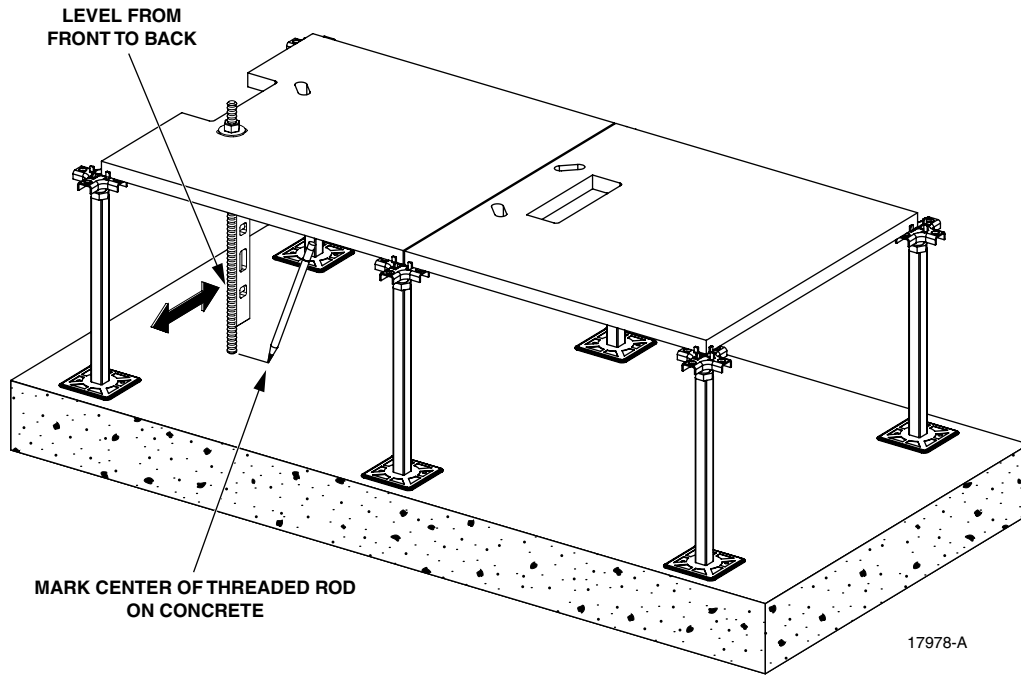

REPEAT STEPS 14 AND 15 USING SAME THREADED ROD FOR REMAINING THREE SLOTS

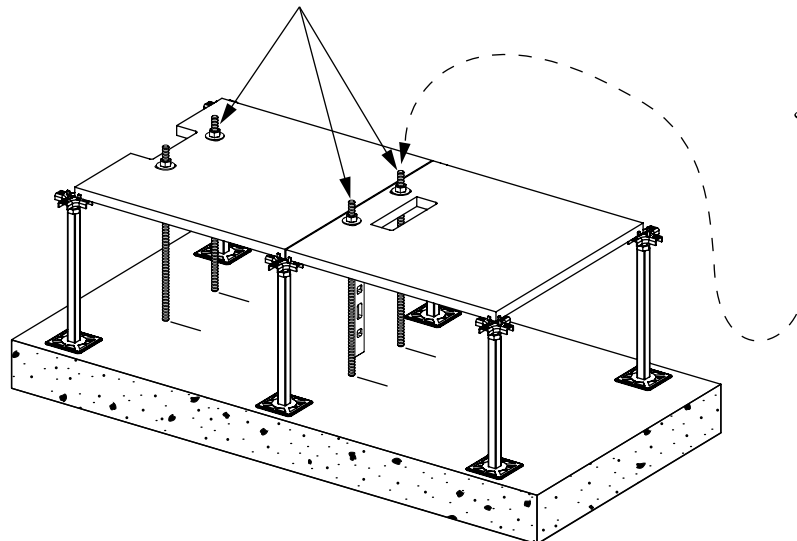

RAISED FLOOR INSTALLATION

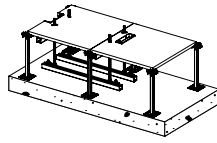

16 REMOVE THREADED ROD ASSEMBLY

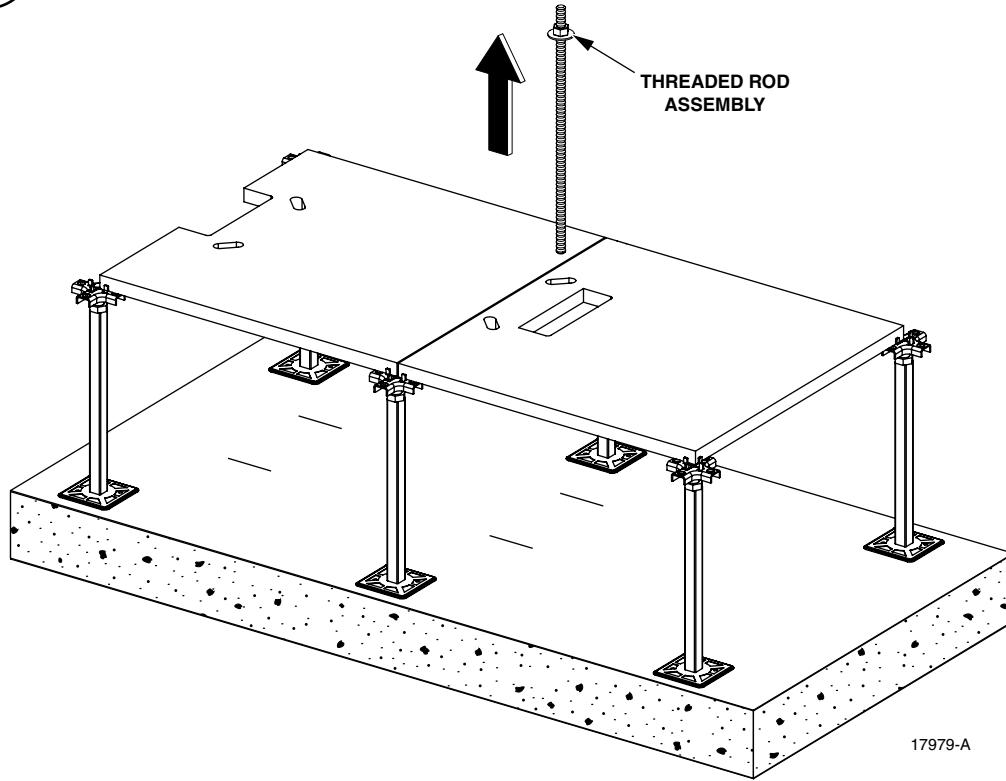

RAISED FLOOR INSTALLATION

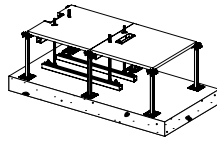

17 USE RULER OR STRAIGHT EDGE TO MARK CONCRETE

RULER OR STRAIGHT EDGE

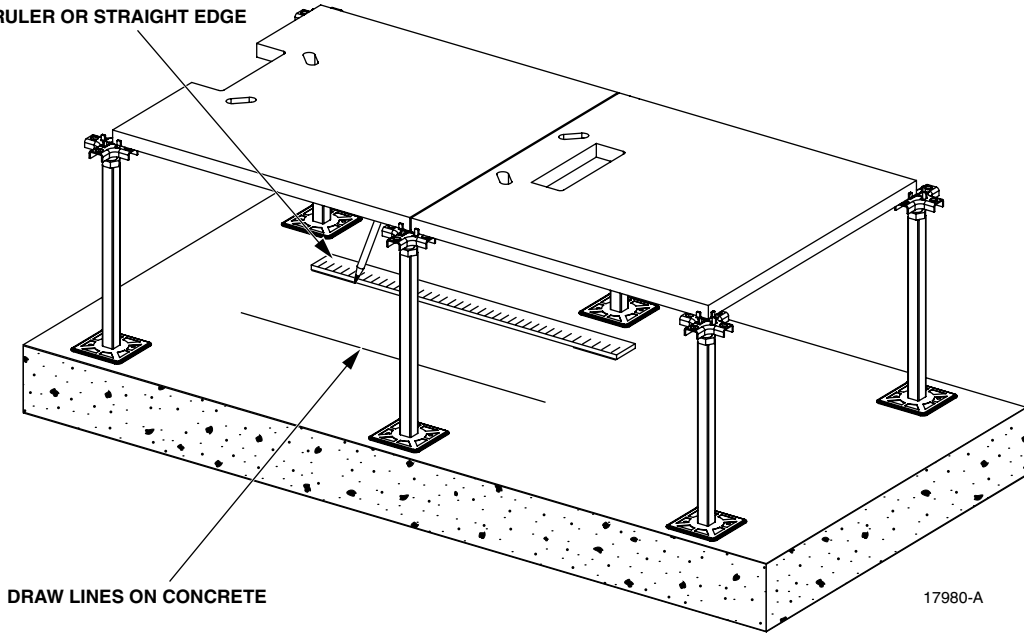

DRAW LINES ON CONCRETE

17980-A

RAISED FLOOR INSTALLATION

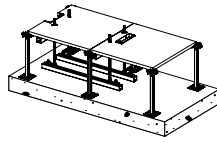

18 CENTER UNISTRUTS ON LINES

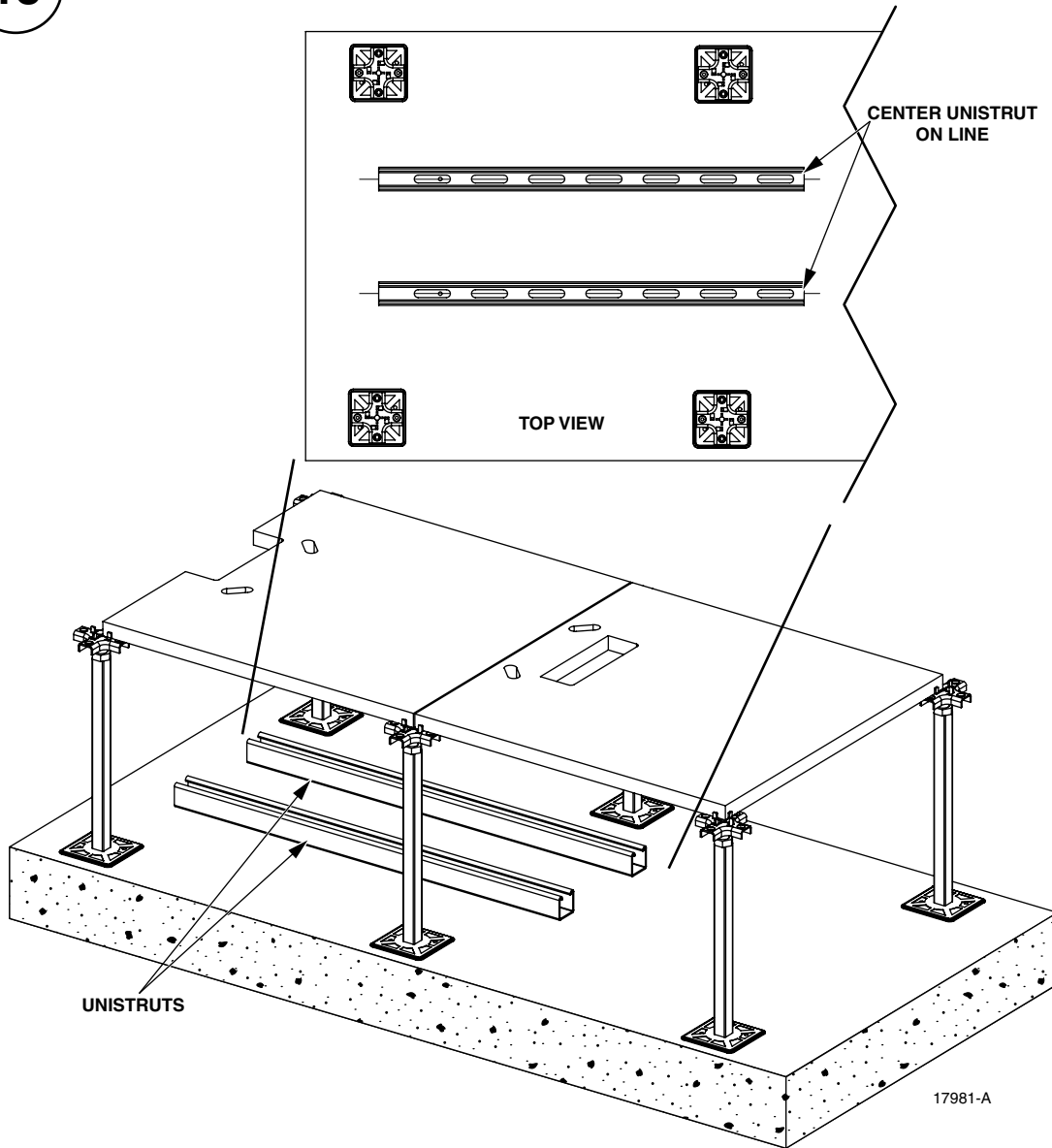

RAISED FLOOR INSTALLATION

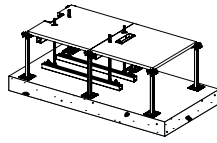

19 INSTALL SPRING NUT IN UNISTRUT

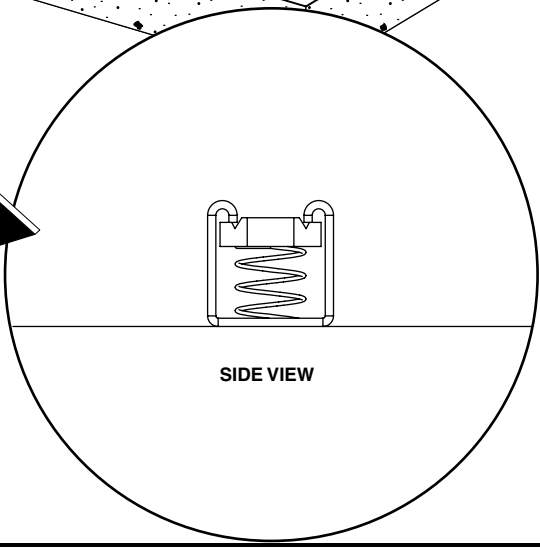
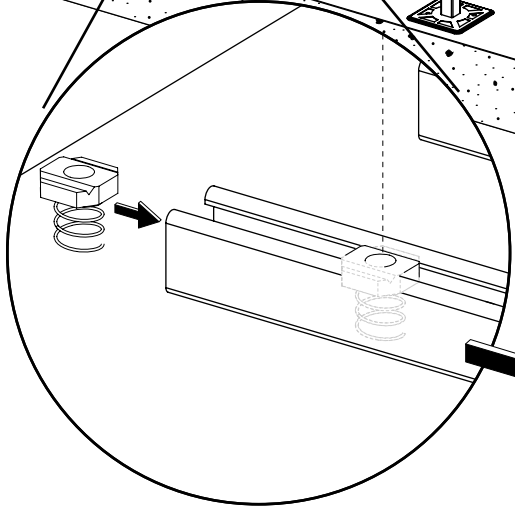
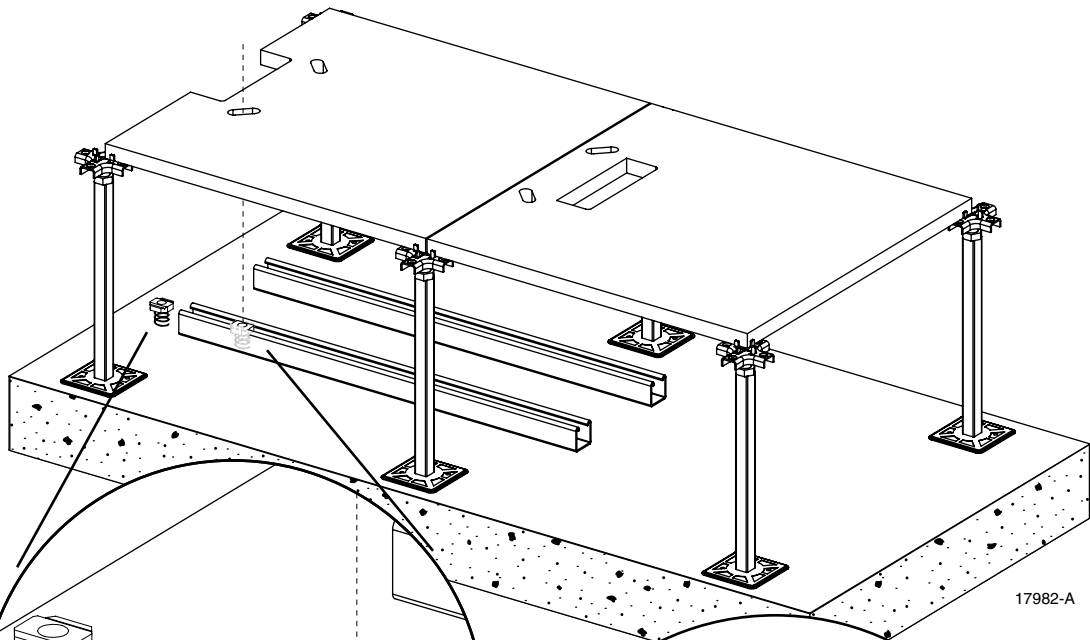

SLIDE SPRING NUT INTO END OF UNISTRUT.
ALIGN SPRING NUT APPROXIMATELY WITH
CENTER OF SLOT IN TILE, AS SHOWN.

17982-A

RAISED FLOOR INSTALLATION

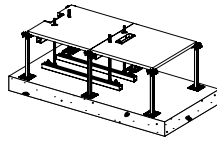

20 ASSEMBLE 5/8" HEX NUT, 5/8" LOCK WASHER, AND 5/8" WASHER ONTO THREADED ROD

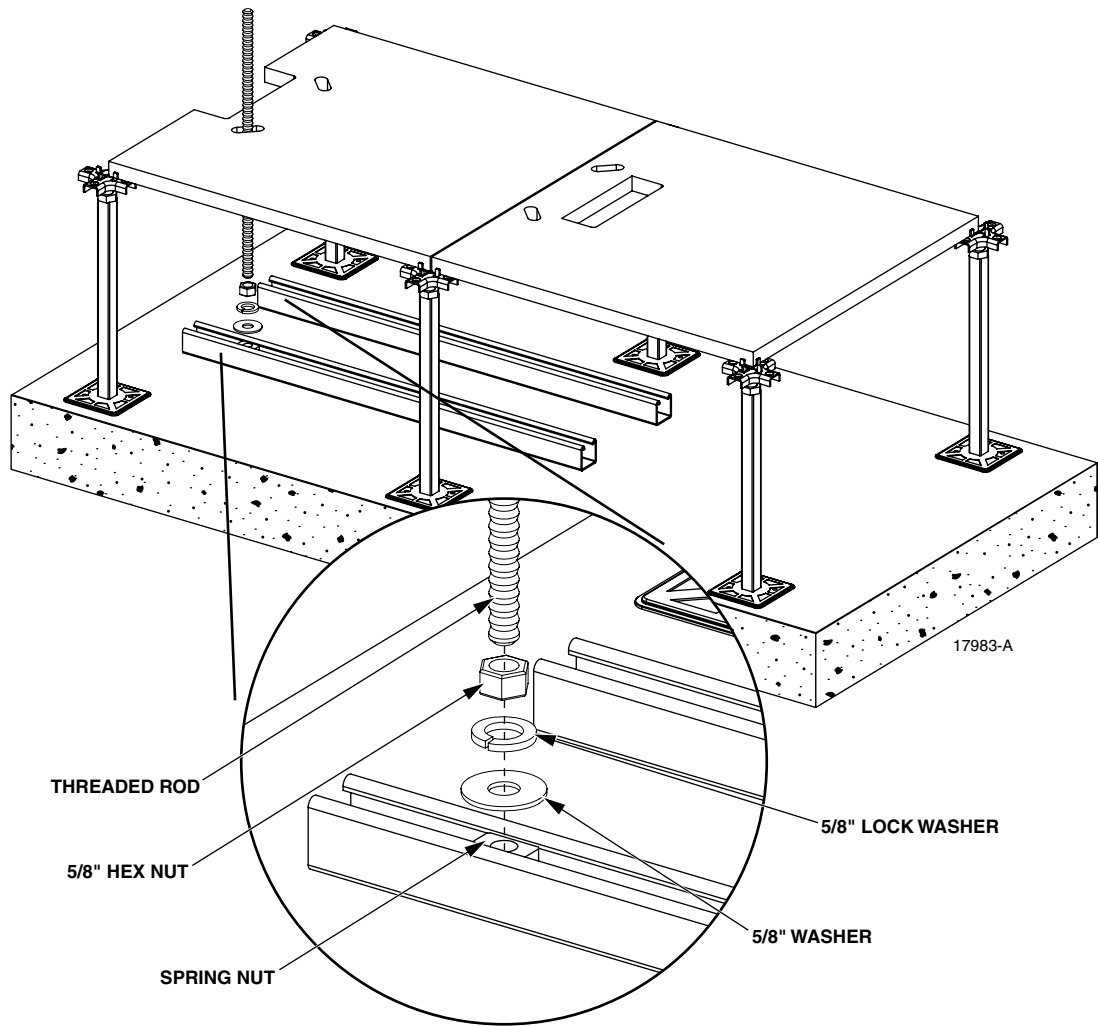

RAISED FLOOR INSTALLATION

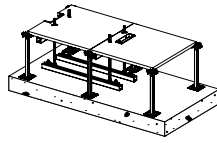

21

INSTALL THREADED ROD ASSEMBLY INTO SPRING NUT

**NOTE: THREADED ROD ASSEMBLY CONSISTS OF THE FOLLOWING PARTS:
THREADED ROD, 5/8" WASHER, 5/8" LOCK WASHER, AND 5/8" HEX NUT**

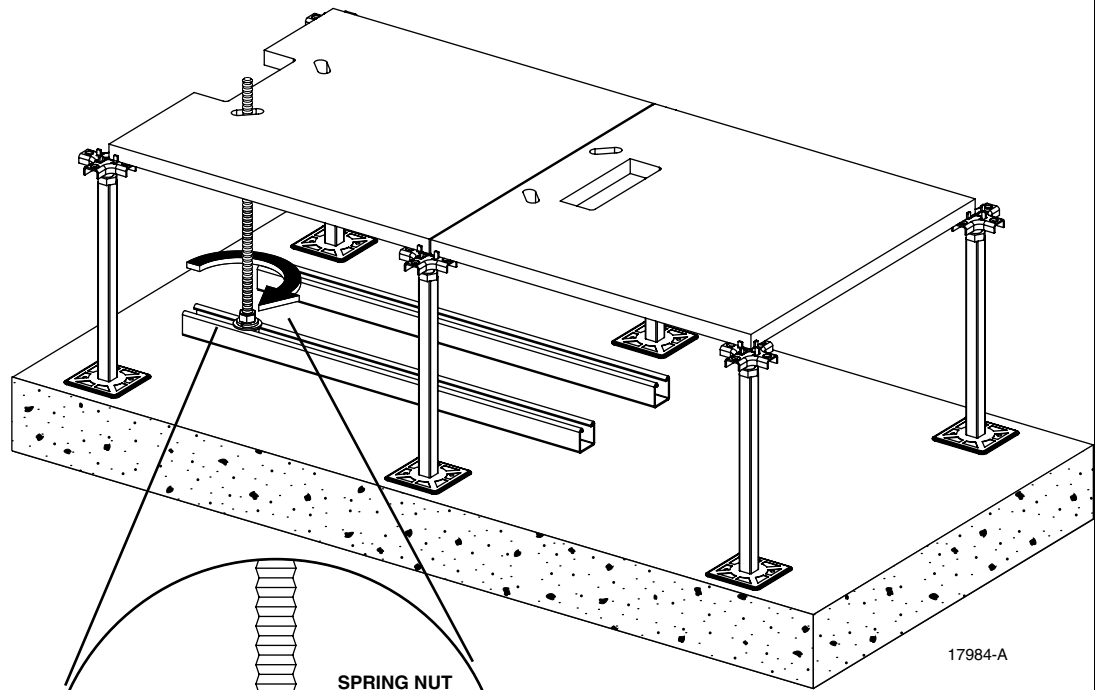

17984-A

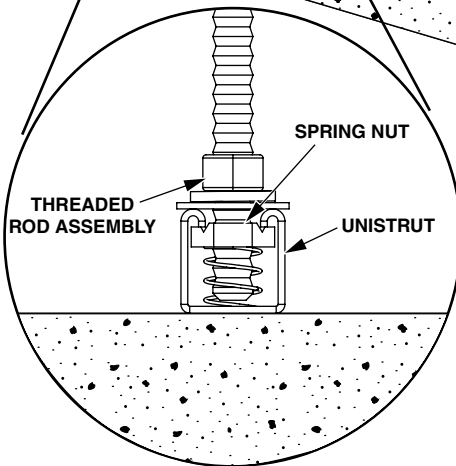

RAISED FLOOR INSTALLATION

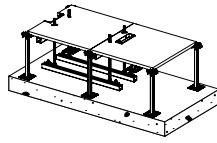

22 LEVEL THE THREADED ROD AND MARK THE ANCHOR PLATE LOCATION ON CONCRETE

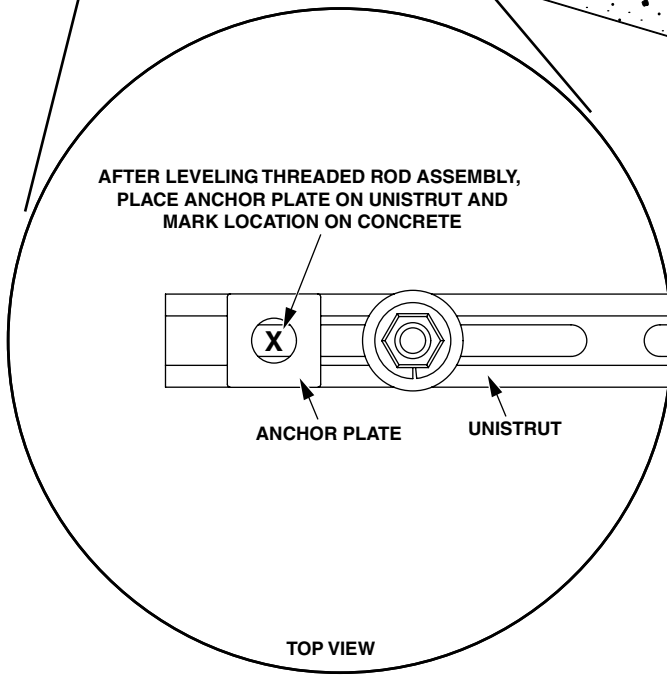
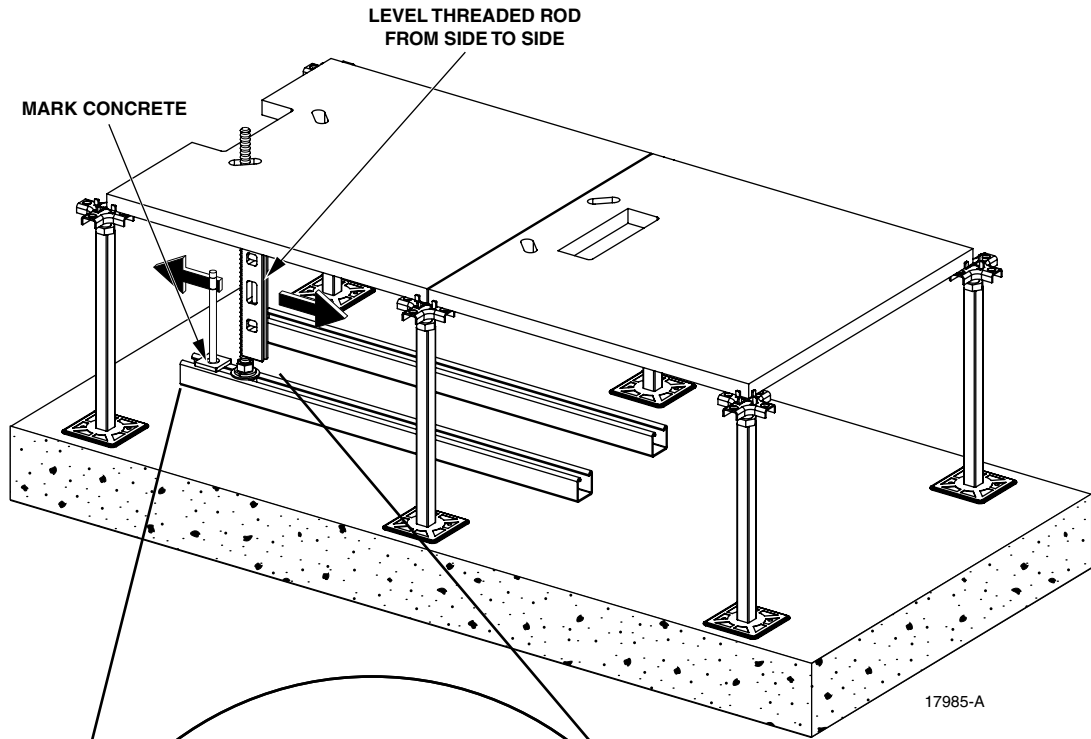

RAISED FLOOR INSTALLATION

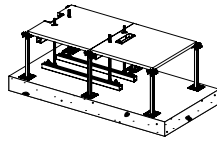

23 REPEAT STEPS 19 THROUGH 22 FOR REMAINING THREADED RODS

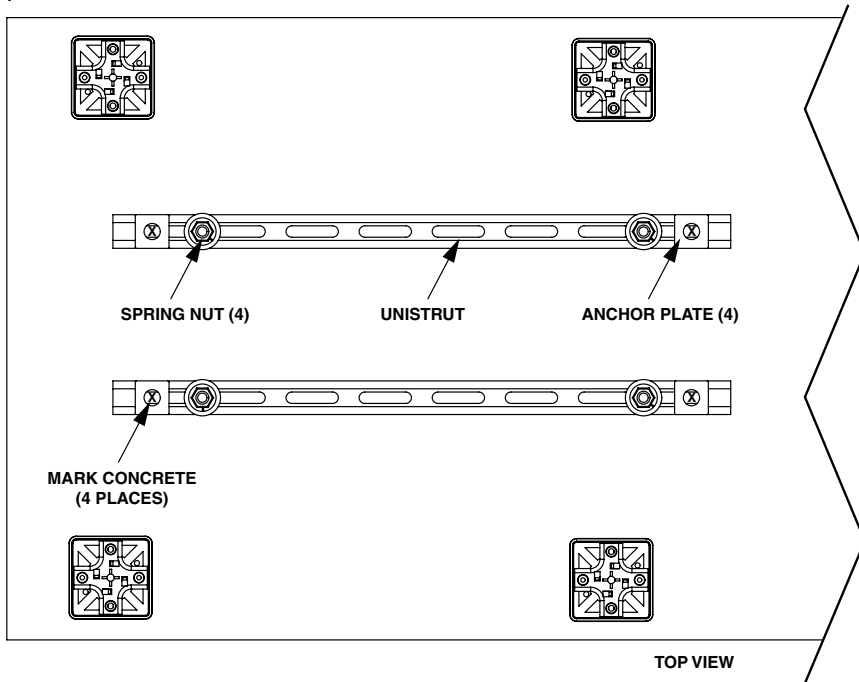
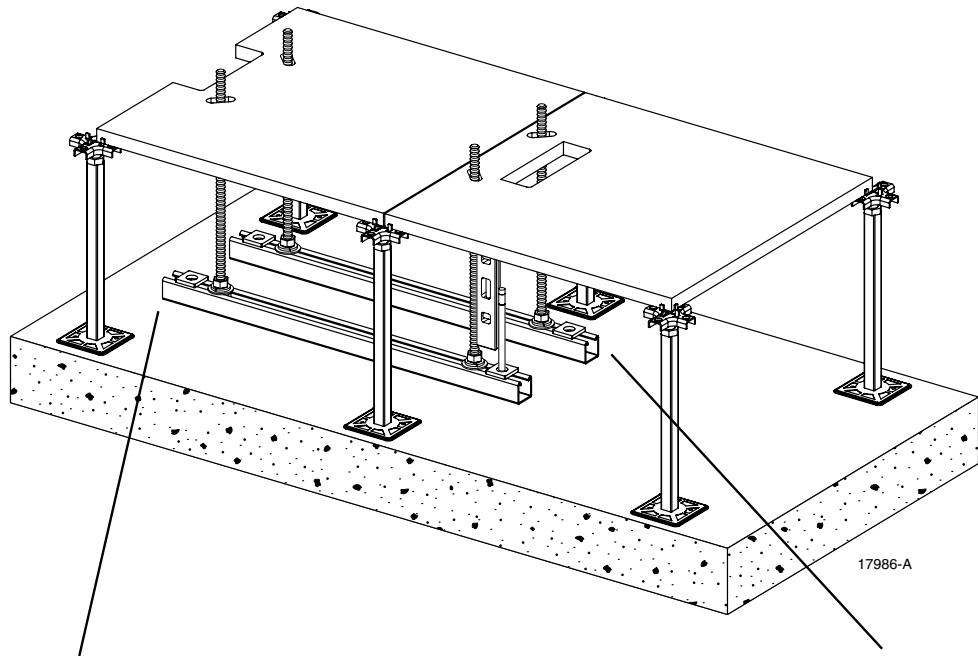

RAISED FLOOR INSTALLATION

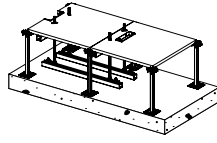

24

SET FLOOR TILES AND UNISTRUT ASSEMBLIES ASIDE

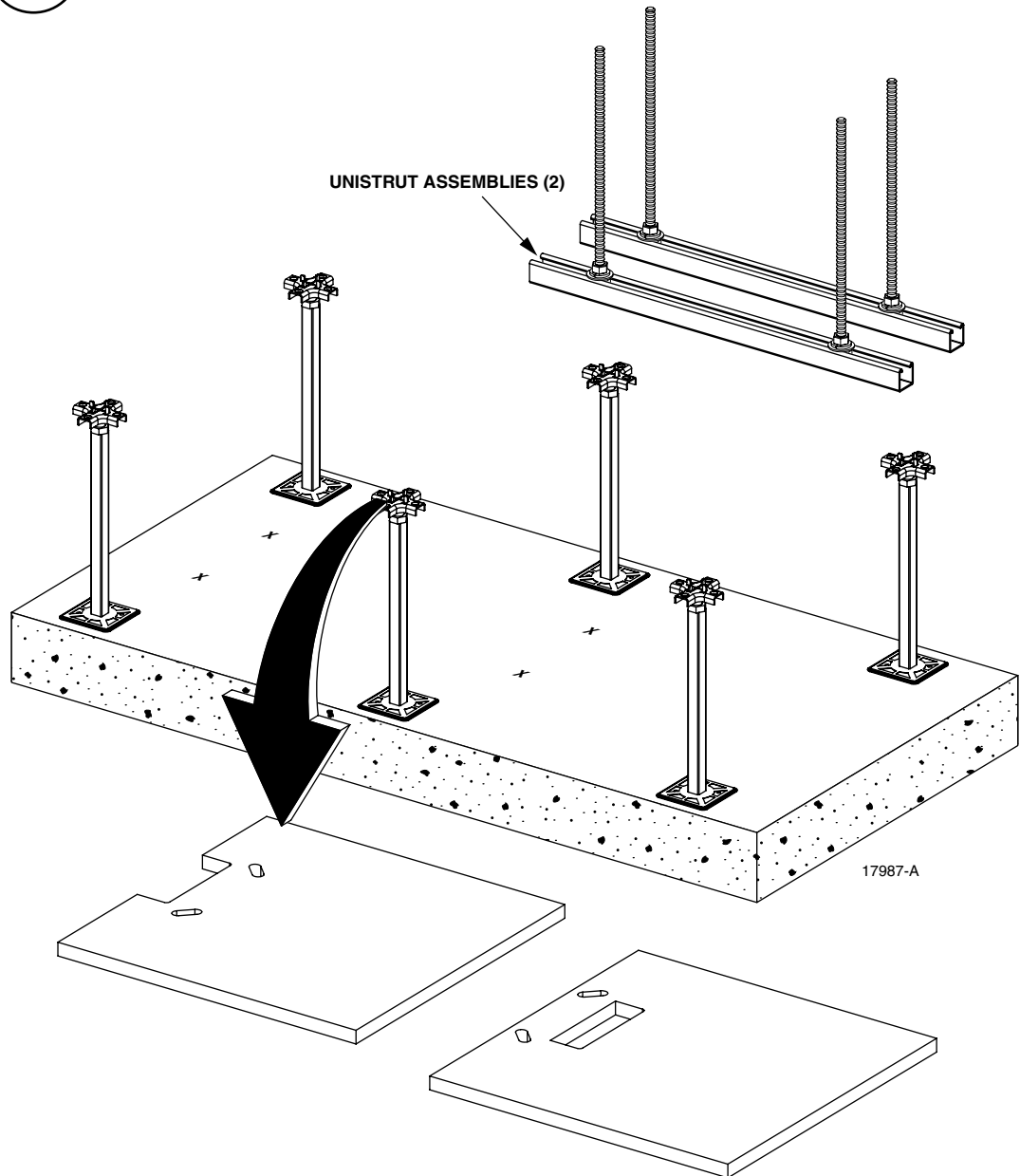

RAISED FLOOR INSTALLATION

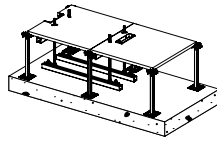

25 DRILL HOLES (4)

HOLE DIMENSIONS:
DIAMETER: 0.71-IN. (18mm)
DEPTH: 3-15/16-IN. (100mm)

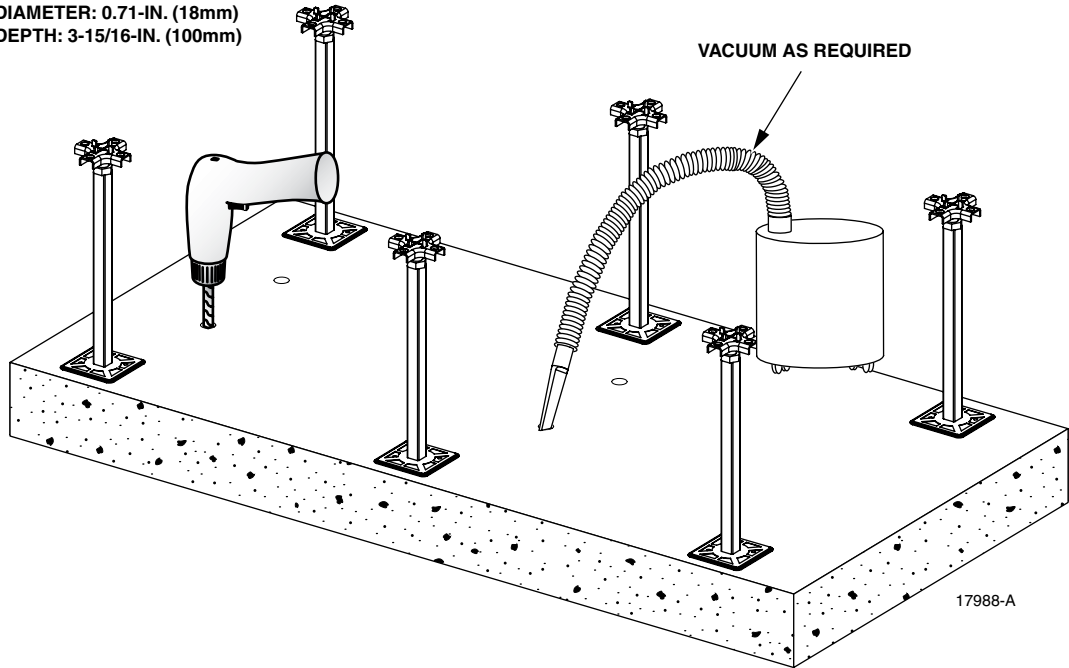

RAISED FLOOR INSTALLATION

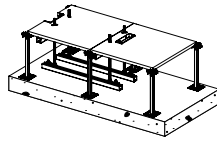

26

THREAD THE WASHER AND TORQUE NUT ONTO THE THEADED ROD.
THE WASHER SHOULD TOUCH THE TOP OF THE ANCHOR SLEEVE.

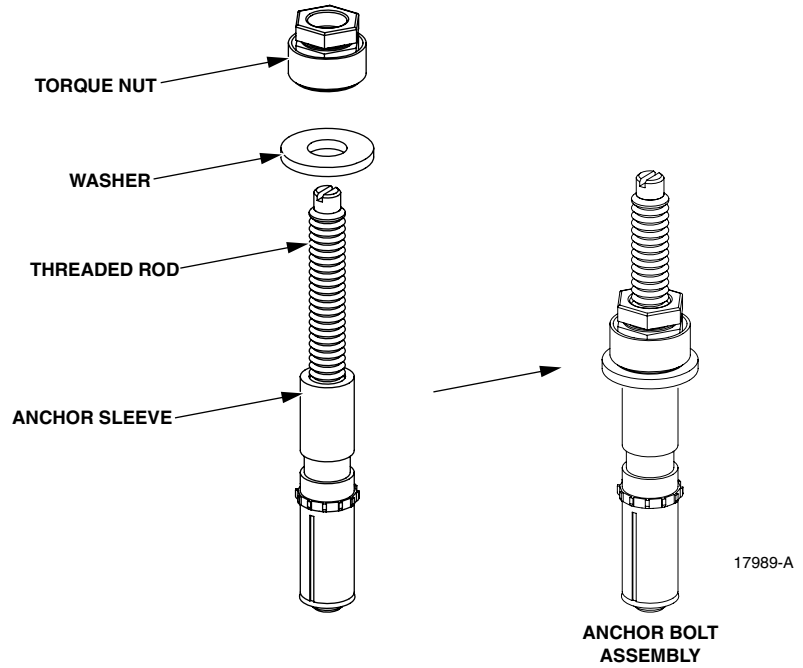

RAISED FLOOR INSTALLATION

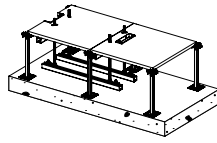

27

**INSERT THE ANCHOR BOLT ASSEMBLY INTO THE HOLE.
TAP THE ANCHOR BOLT ASSEMBLY WITH A HAMMER UNTIL THE WASHER TOUCHES THE CONCRETE.**

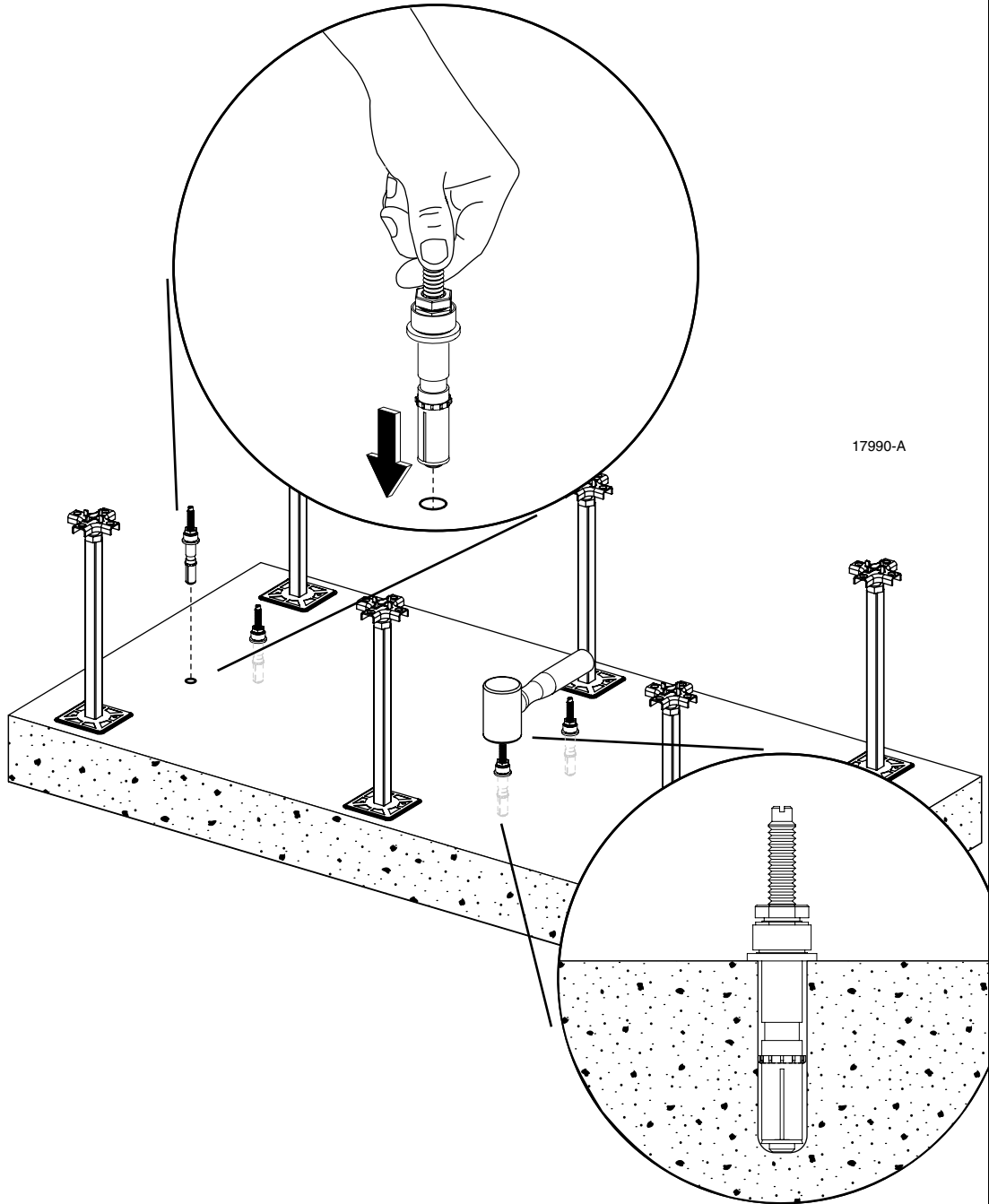

17990-A

RAISED FLOOR INSTALLATION

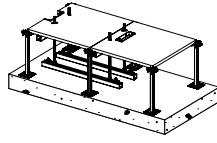

28 USE REFERENCE DIRECTION FROM LABEL INCLUDED ON THE ANCHOR BAG TO INSTALL THE ANCHOR BOLT.

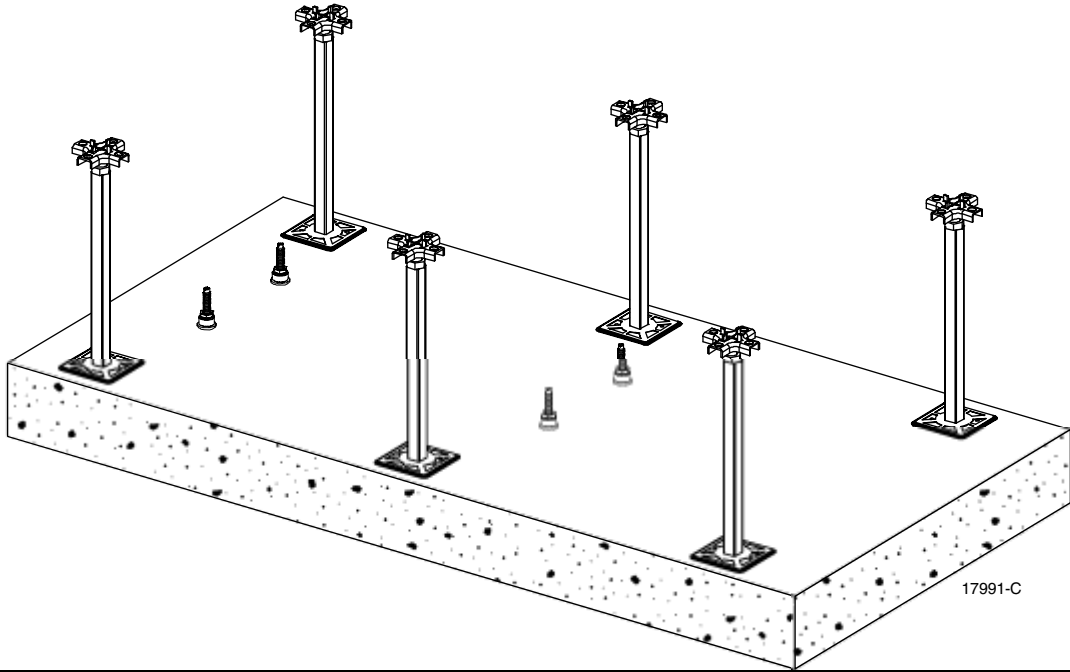

RAISED FLOOR INSTALLATION

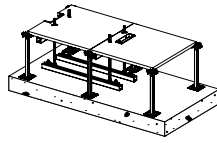

29 LOOSEN THE TORQUE NUT SEVERAL TURNS, THEN REMOVE THE TORQUE NUT AND WASHER.

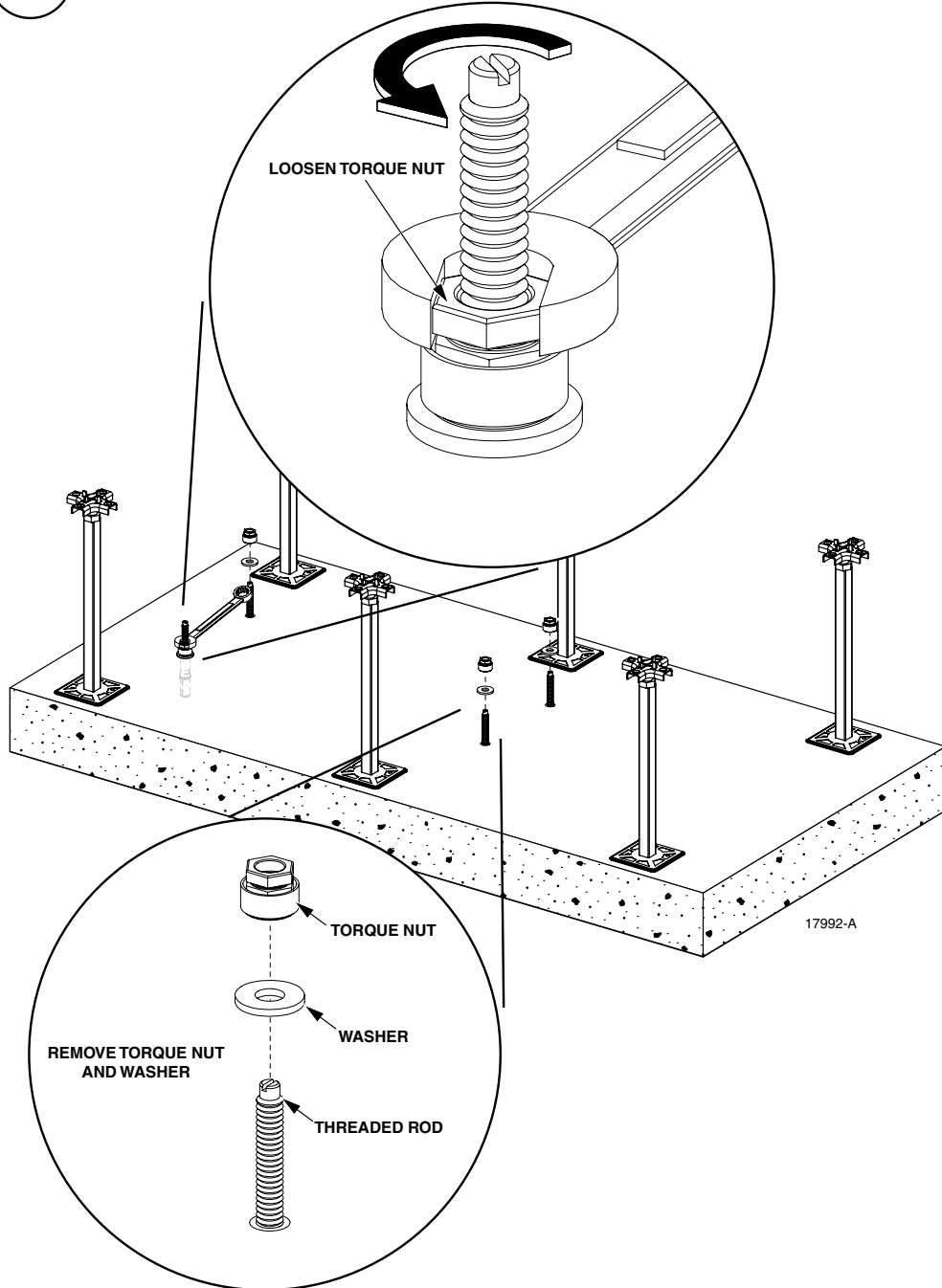

RAISED FLOOR INSTALLATION

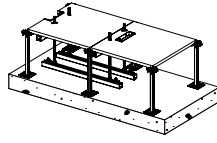

30

POSITION UNISTRUT ASSEMBLIES (2) OVER THREADED RODS

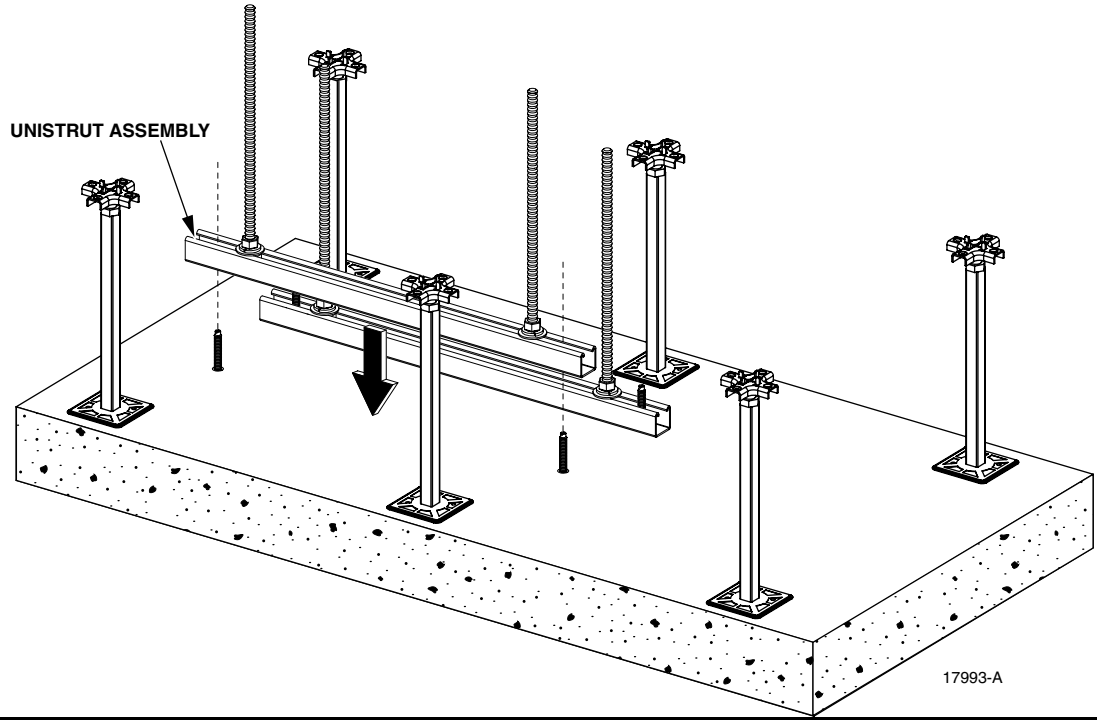

RAISED FLOOR INSTALLATION

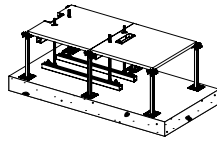

31

ASSEMBLE ANCHOR PLATE, FLAT WASHER, AND TORQUE NUT ONTO THREADED ROD

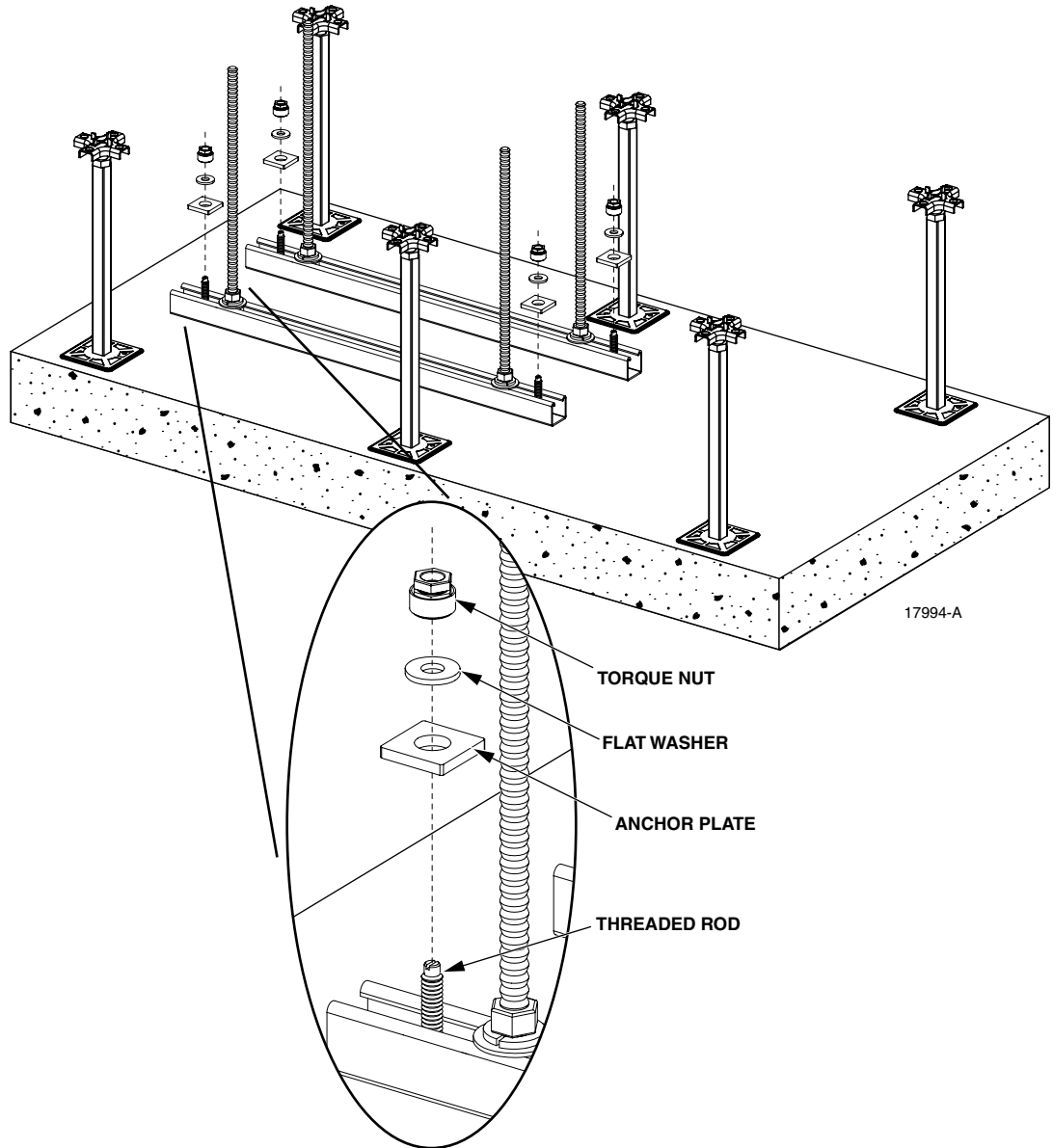

17994-A

RAISED FLOOR INSTALLATION

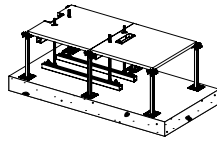

32

TIGHTEN TORQUE NUT UNTIL TOP FLANGE SHEARS OFF (4 PLACES).

NOTE:

NOTE: THE TORQUE NUT WILL BE CORRECTLY SET AT 60 FT-LBS (81N-m) AS INDICATED ON THE LABEL FROM THE ANCHOR BOLT BAG.

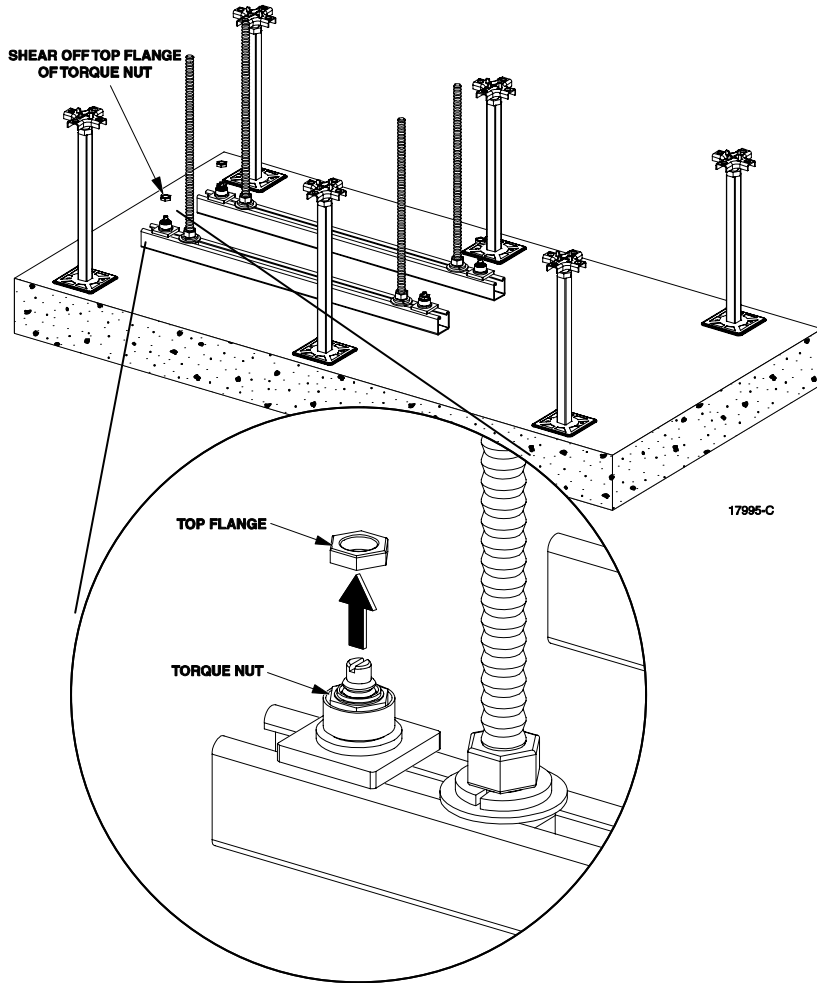

RAISED FLOOR INSTALLATION

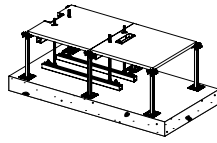

33 CUT EDGE PROTECTOR TO REQUIRED LENGTH AND SECURE IT TO FLOOR TILES PER LOCAL REQUIREMENTS DEPENDING ON TYPE AND COMPOSITION OF FLOOR TILE.

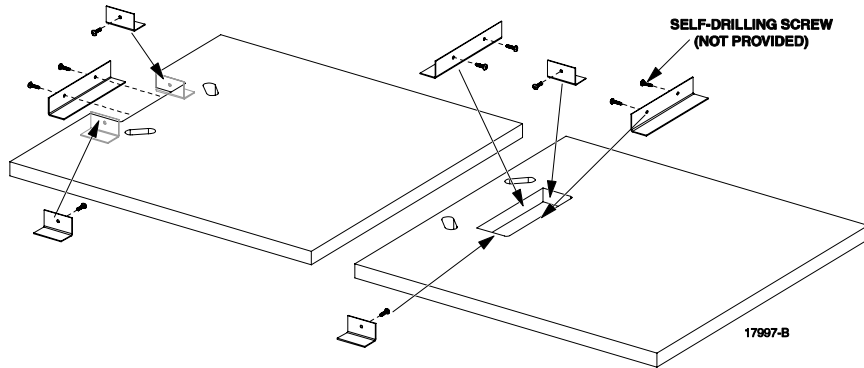
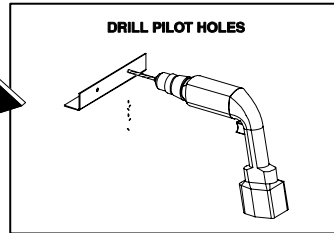
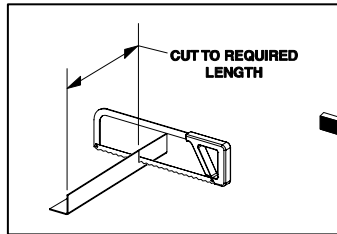

RAISED FLOOR INSTALLATION

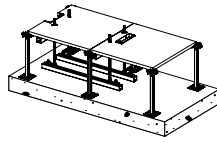

34

ASSEMBLE HEX NUTS, SPLIT LOCK WASHERS, FLAT WASHERS, UNISTRUTS, AND FLOOR TILES ONTO THREADED RODS

NOTE: ADJUST HEX NUTS, AS REQUIRED, MAKING SURE FLOOR TILES ARE NOT RAISED OFF OF PEDESTALS.

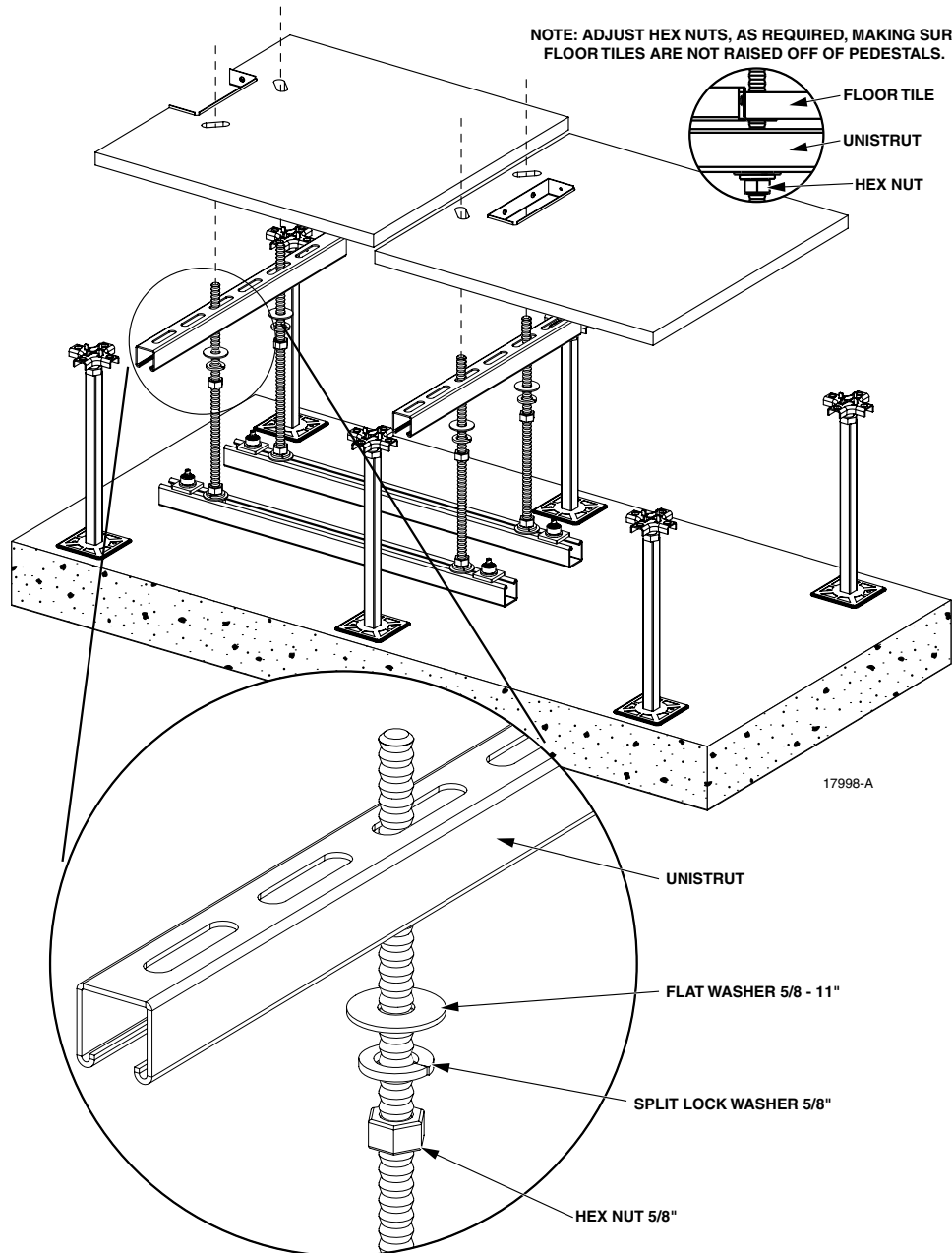

RAISED FLOOR INSTALLATION

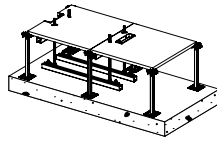

35

LEVEL THREADED ROD ASSEMBLIES (4) AND TIGHTEN HEX NUTS (4)

**LEVEL THREADED ROD ASSEMBLIES
SIDE TO SIDE**

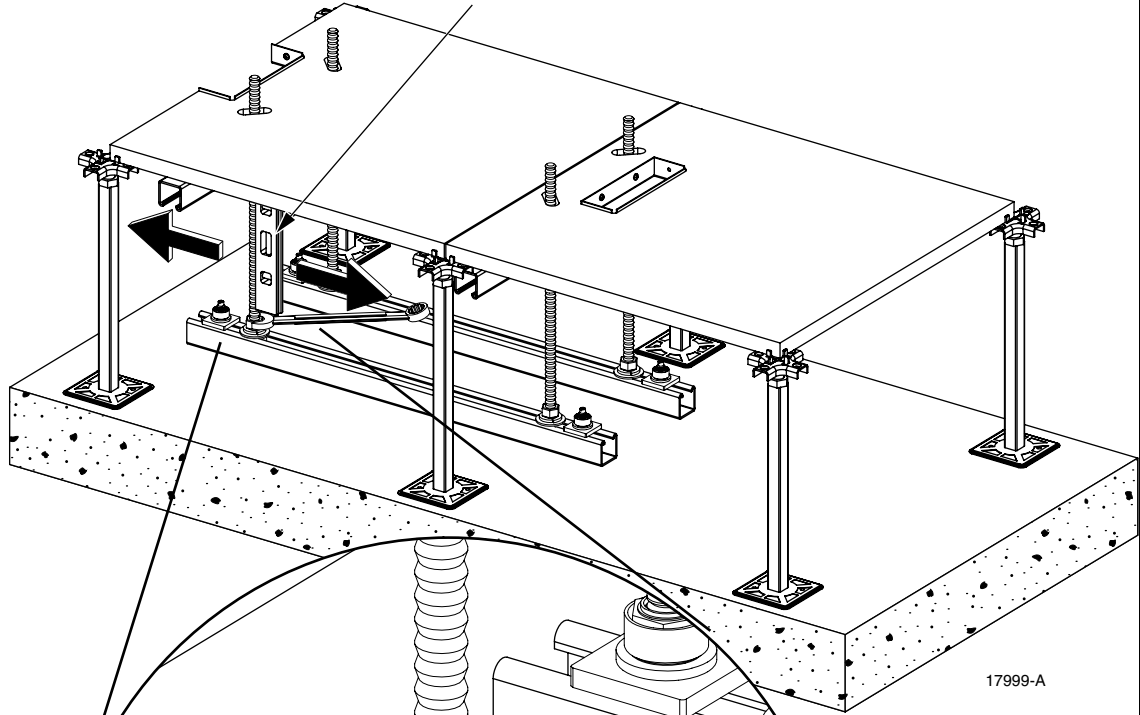

TIGHTEN HEX NUT (4)

17999-A

RAISED FLOOR INSTALLATION

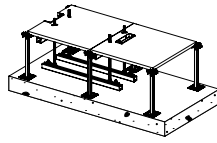

36 HAND TIGHTEN HEX NUTS TO RAISE UNISTRUTS TO FLOOR TILE

! MAKE SURE FLOOR TILES ARE NOT RAISED OFF PEDESTALS

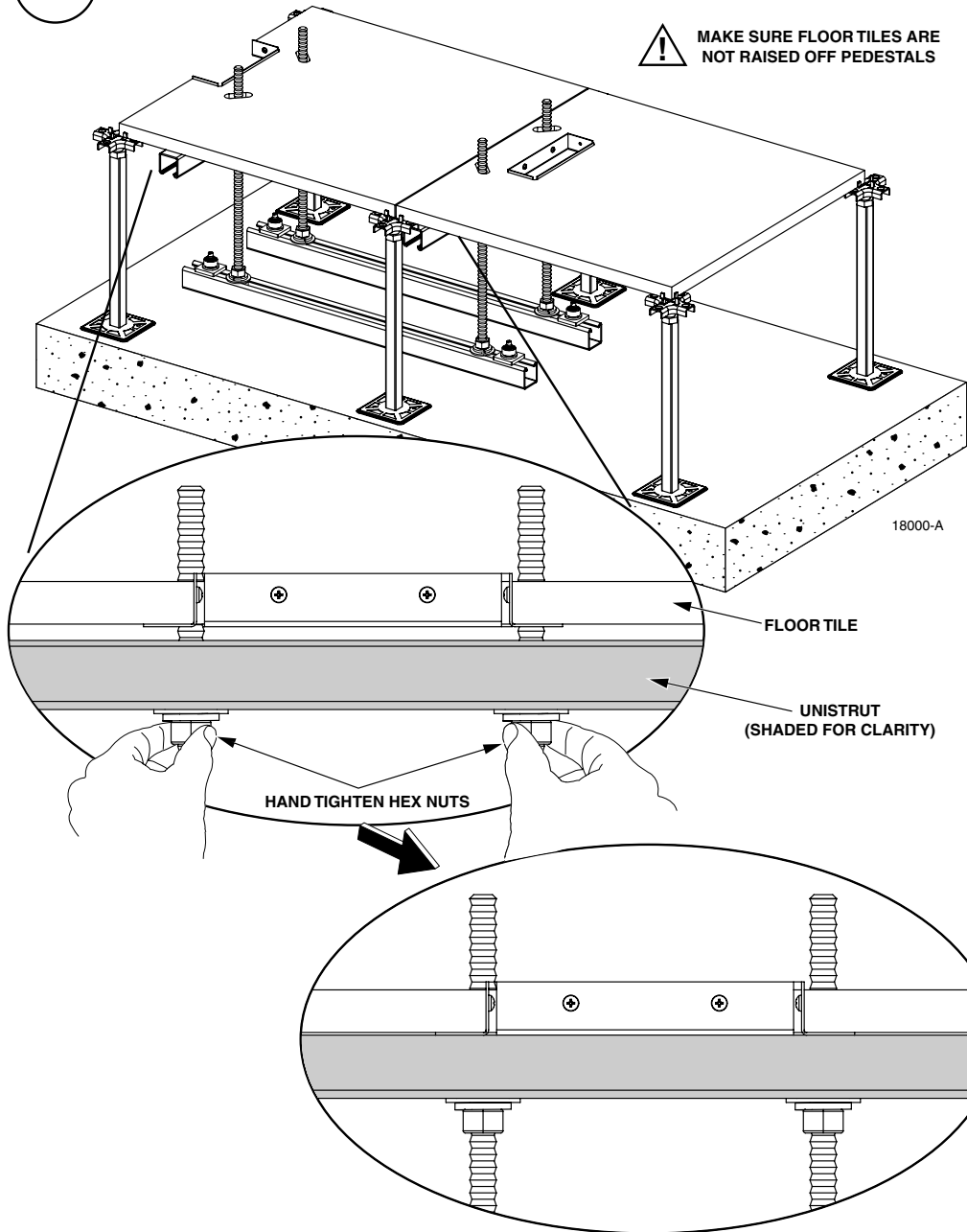

RAISED FLOOR INSTALLATION

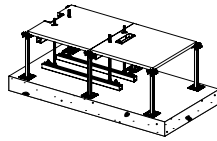

CAUTION: A RACK LOADED WITH PANELS WEIGHS APPROXIMATELY 204.12 KILOS (450 LBS). DO NOT ATTEMPT TO LIFT OR MOVE THE RACK WITHOUT USING APPROPRIATE EQUIPMENT

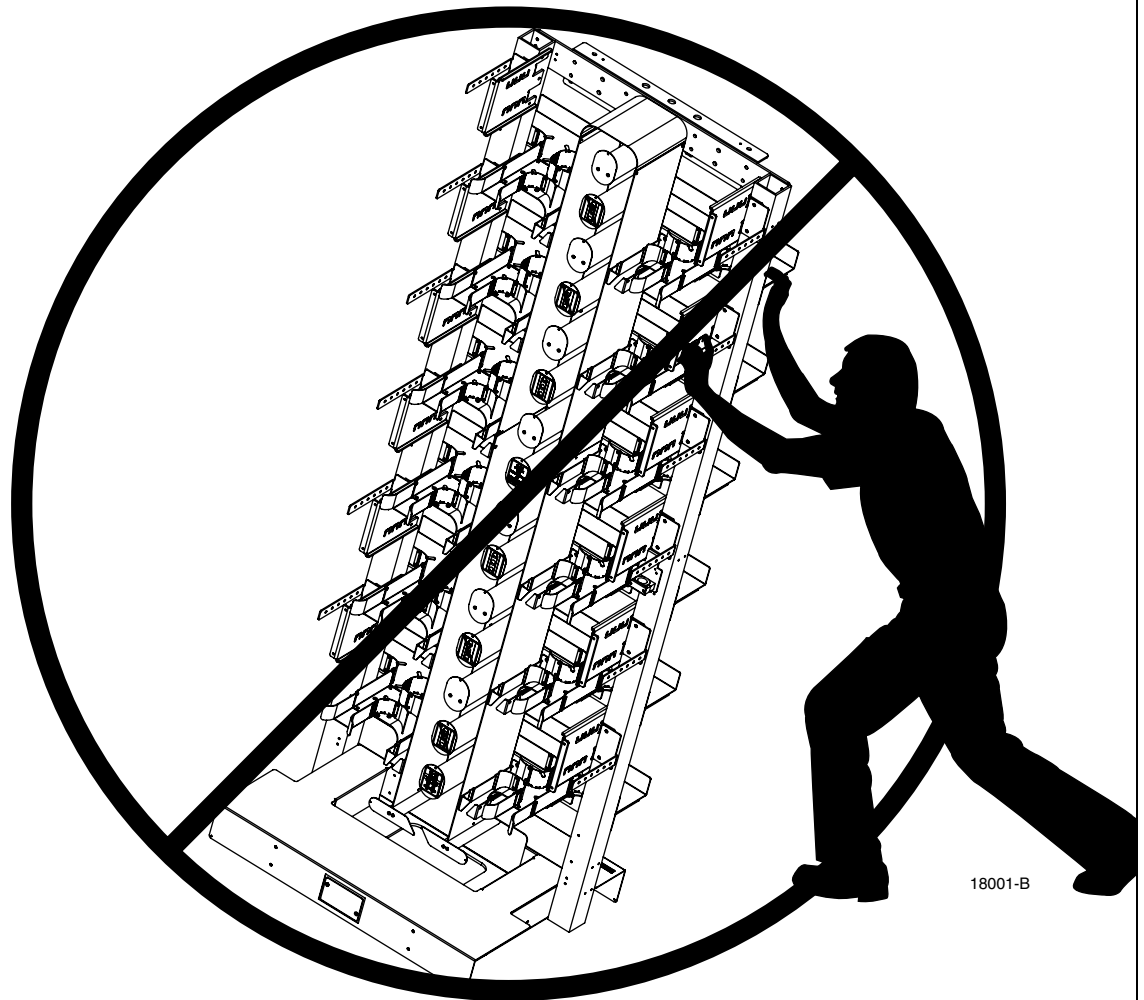

18001-B

RAISED FLOOR INSTALLATION

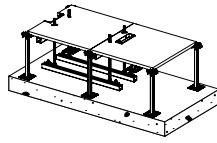

37 REMOVE KICK PLATE TO ACCESS MOUNTING SLOTS IN BASE OF RACK

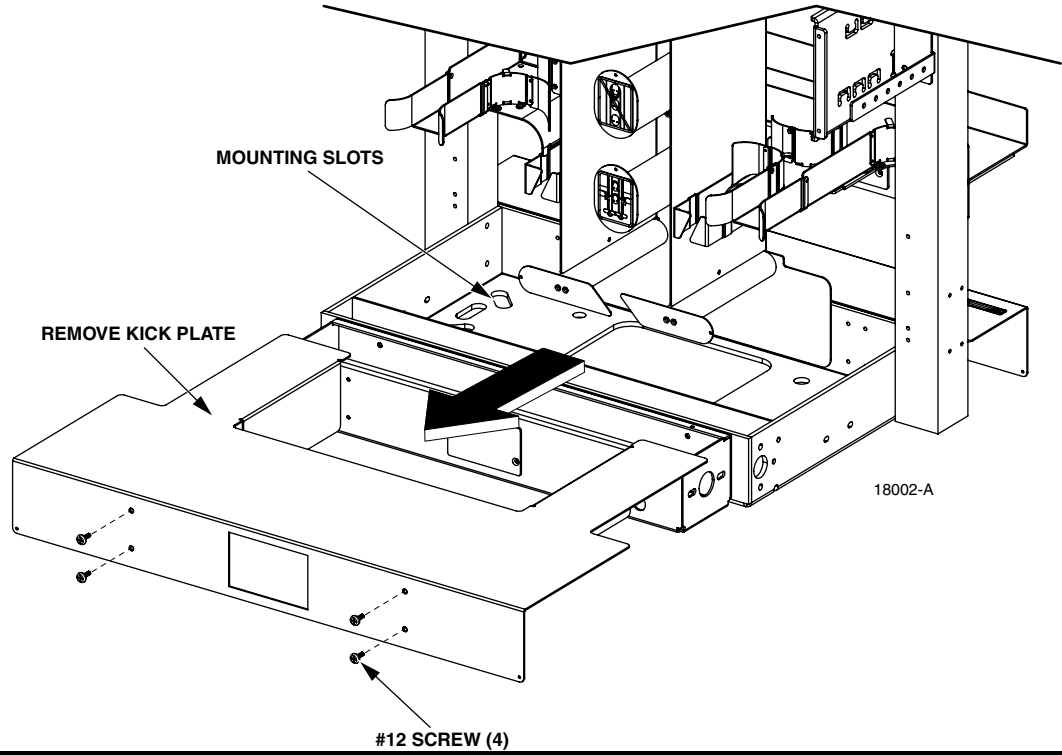

RAISED FLOOR INSTALLATION

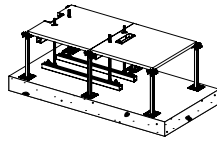

38 POSITION TEMPLATE/ISOLATION PAD AND RACK ON FLOOR TILE AND INSTALL HARDWARE

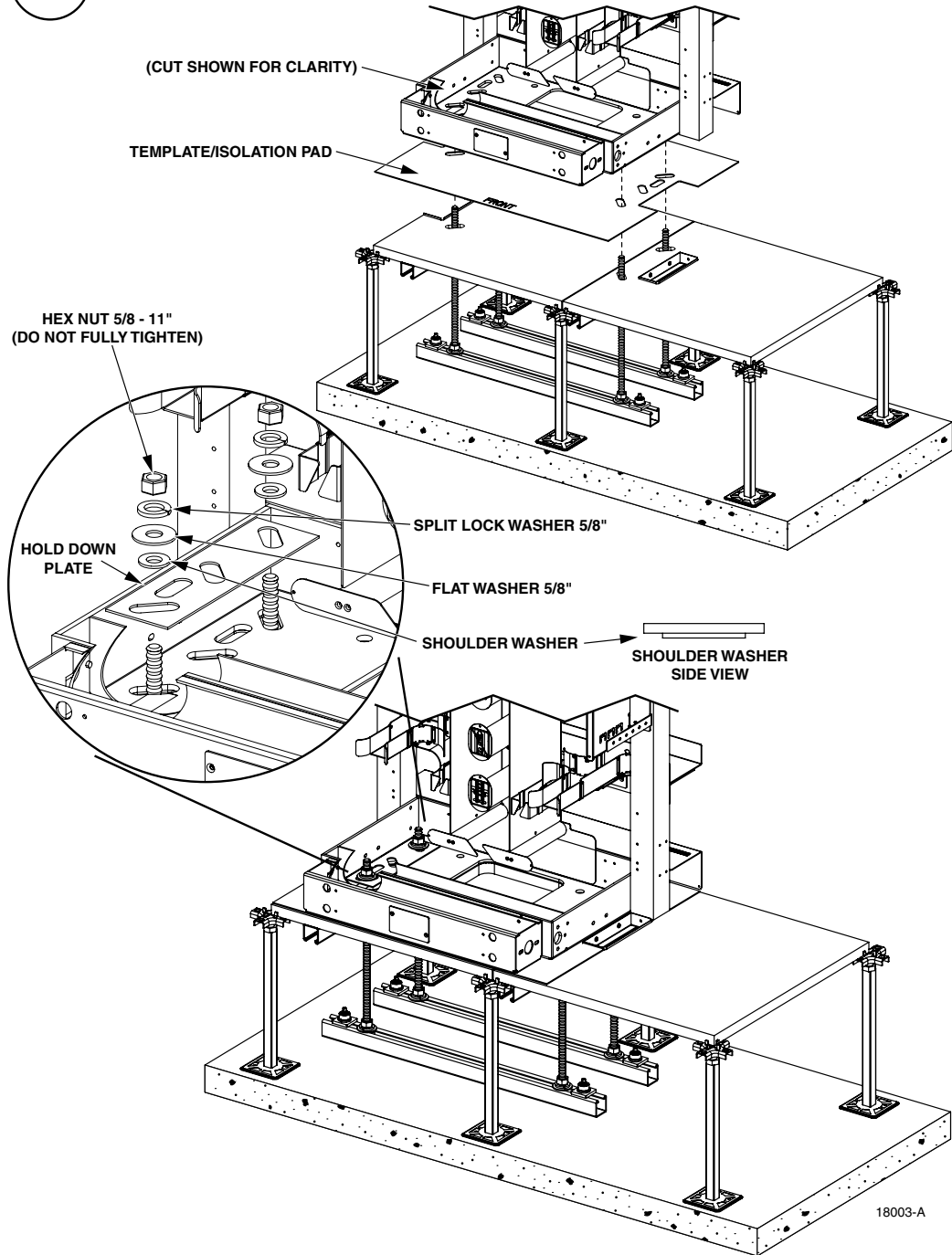

RAISED FLOOR INSTALLATION

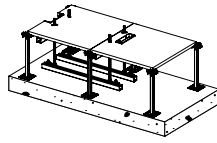

39 USE WRENCH TO TIGHTEN HEX NUTS UNDER FLOOR TILE (DO NOT FULLY TIGHTEN)

TIGHTEN HEX NUTS UNTIL
SPLIT LOCK WASHER IS FLATTENED

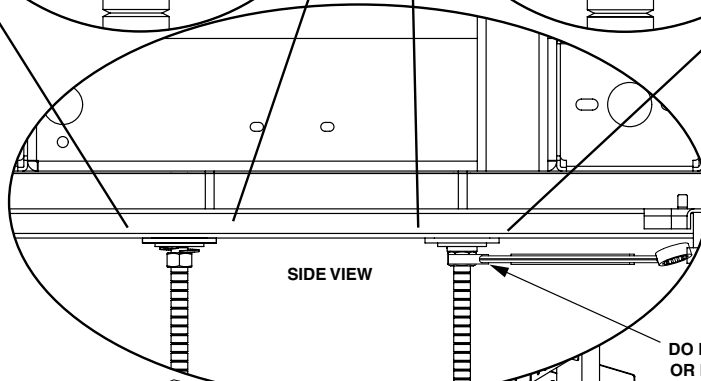
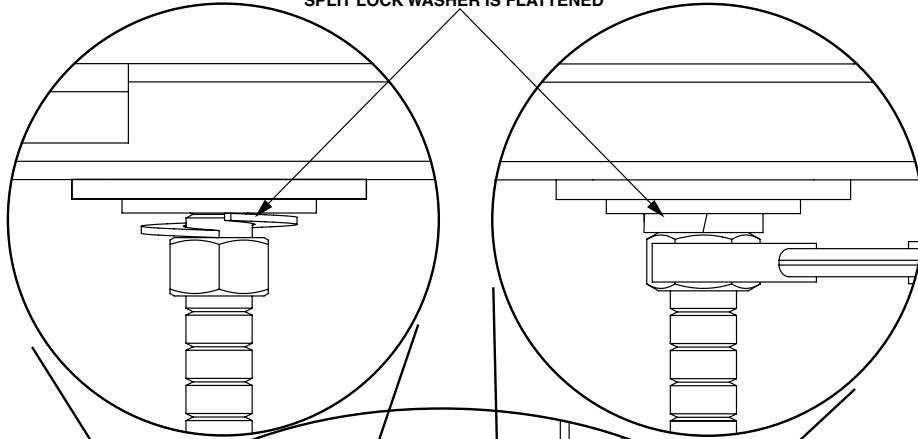

DO NOT FULLY TIGHTEN
OR RAISE FLOOR TILES

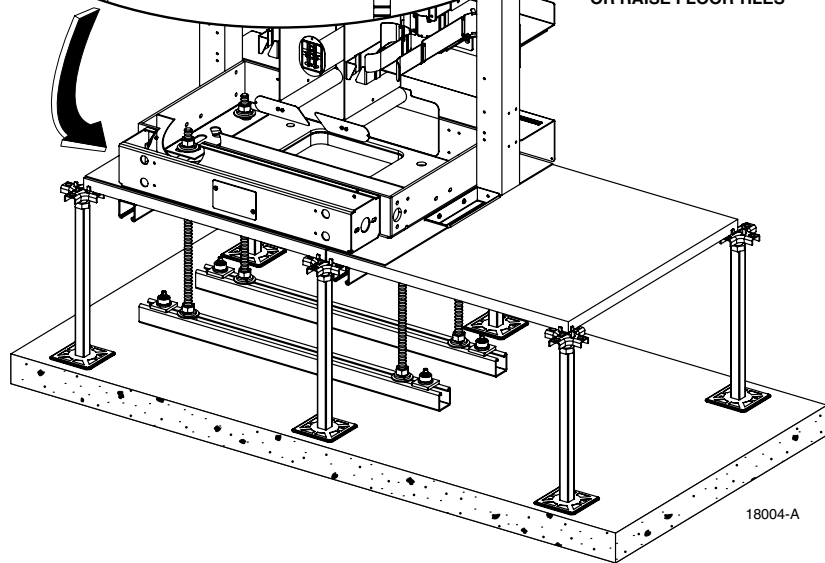

18004-A

RAISED FLOOR INSTALLATION

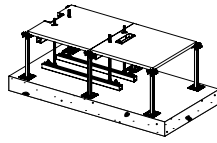

40

FULLY TIGHTEN HEX NUTS ABOVE FLOOR TILE, THEN FULLY TIGHTEN HEX NUTS (4) UNDER FLOOR TILE

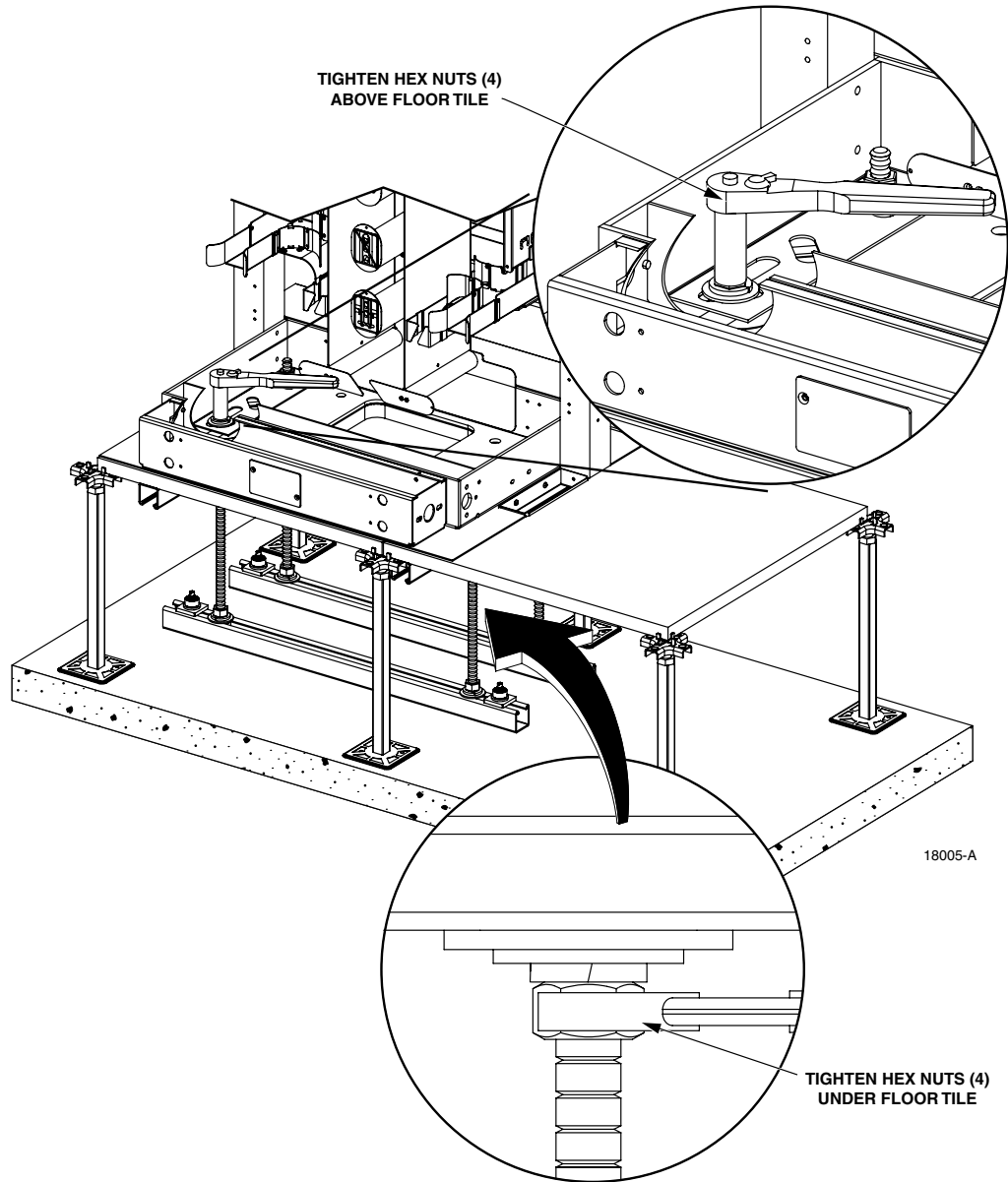

TIGHTEN HEX NUTS (4)
ABOVE FLOOR TILE

TIGHTEN HEX NUTS (4)
UNDER FLOOR TILE

18005-A

RAISED FLOOR INSTALLATION

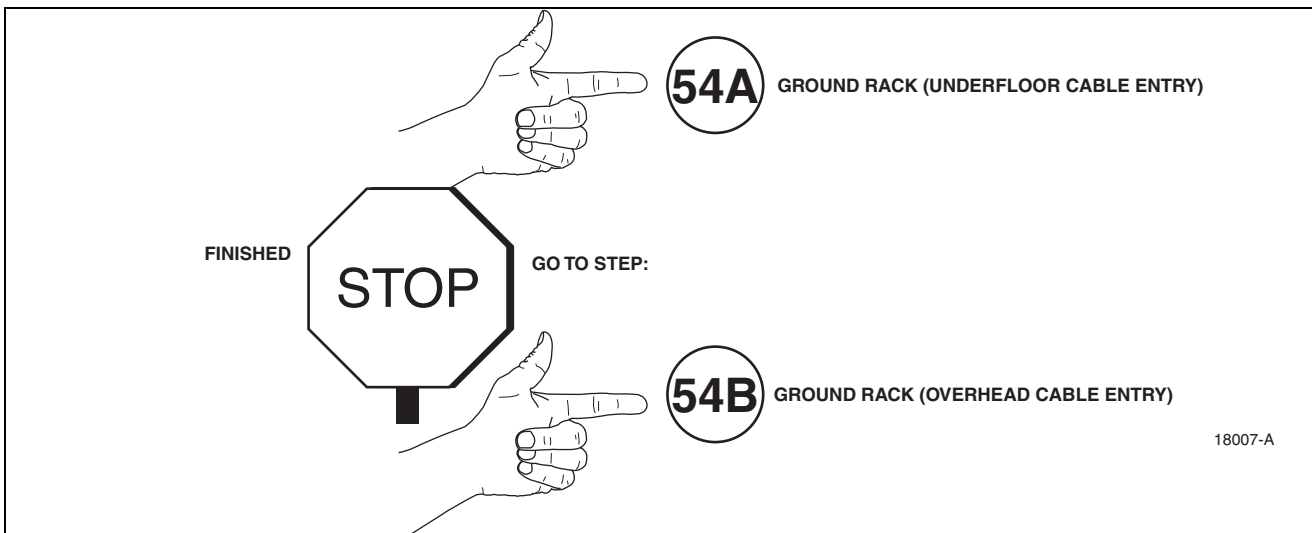
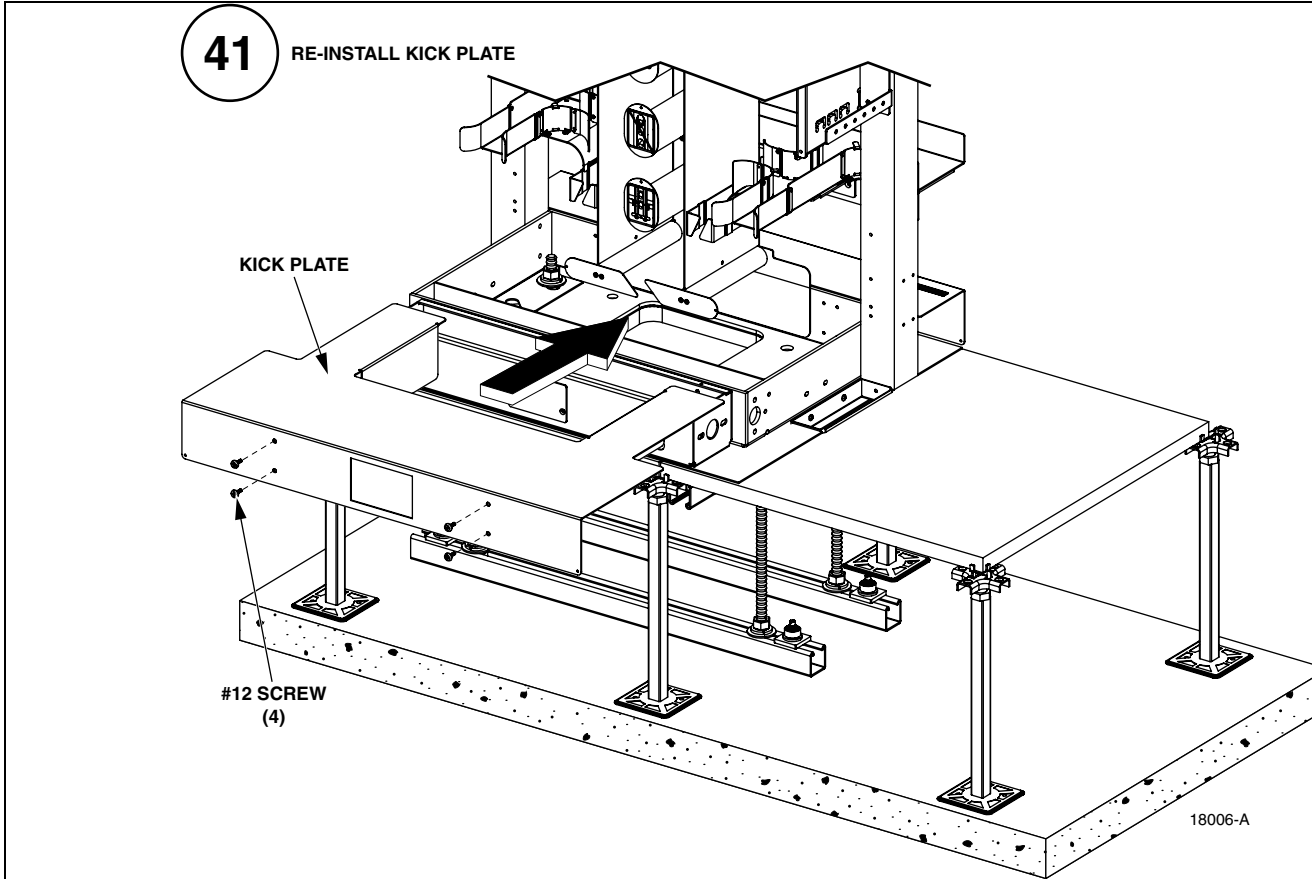
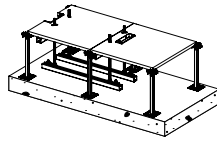

CONCRETE FLOOR INSTALLATION

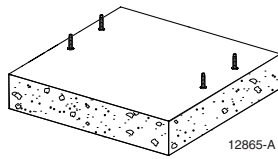

<p>42 — PARTS REQUIRED</p>	
<p>Anchor Bolt Assembly (4) (Provided with Rack)</p>	
<p>HOLD DOWN PLATE (2) (Provided with Rack)</p>	
<p>Hold Down Washer, Square (4) (Provided with Rack)</p>	

CONCRETE FLOOR INSTALLATION

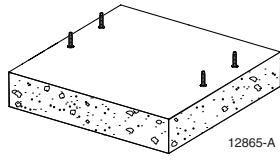

43 PLACE TEMPLATE/ISOLATION PAD ON CONCRETE FLOOR LOCATION AND MARK CONCRETE

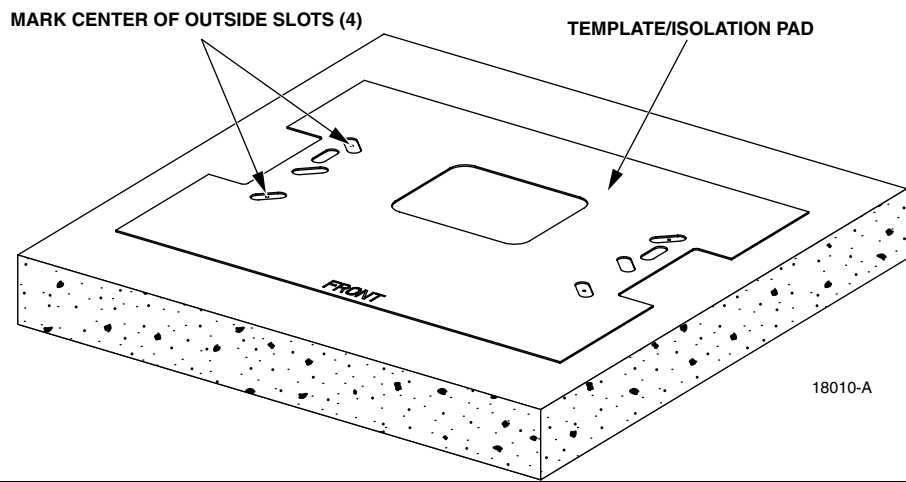

CONCRETE FLOOR INSTALLATION

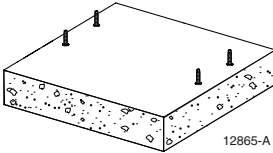

44 SET TEMPLATE ASIDE AND DRILL HOLES IN CONCRETE

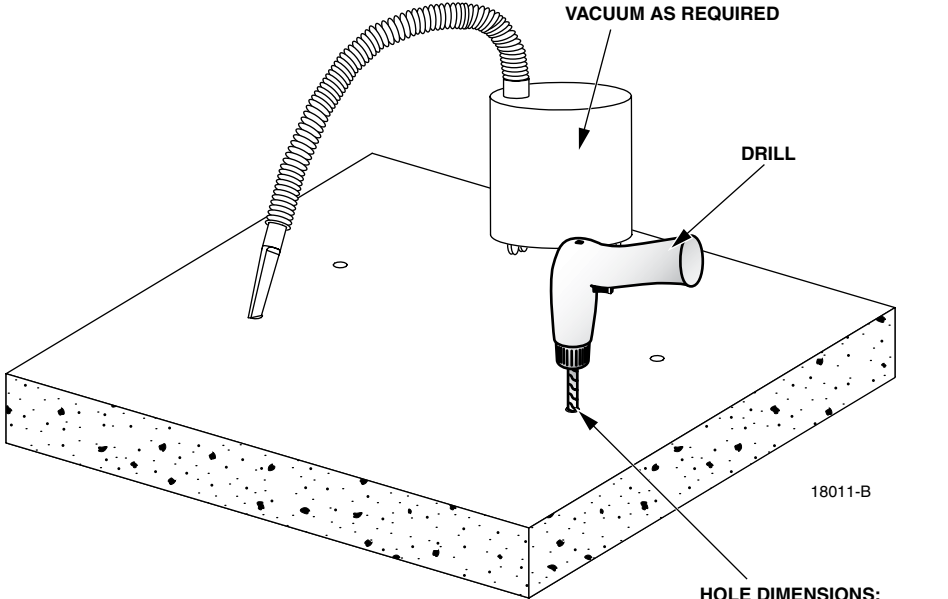

CONCRETE FLOOR INSTALLATION

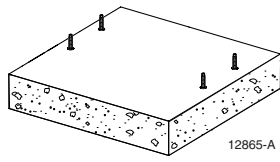

45

THREAD THE WASHER AND TORQUE NUT ONTO THE THEADED ROD.
THE WASHER SHOULD TOUCH THE TOP OF THE ANCHOR SLEEVE.

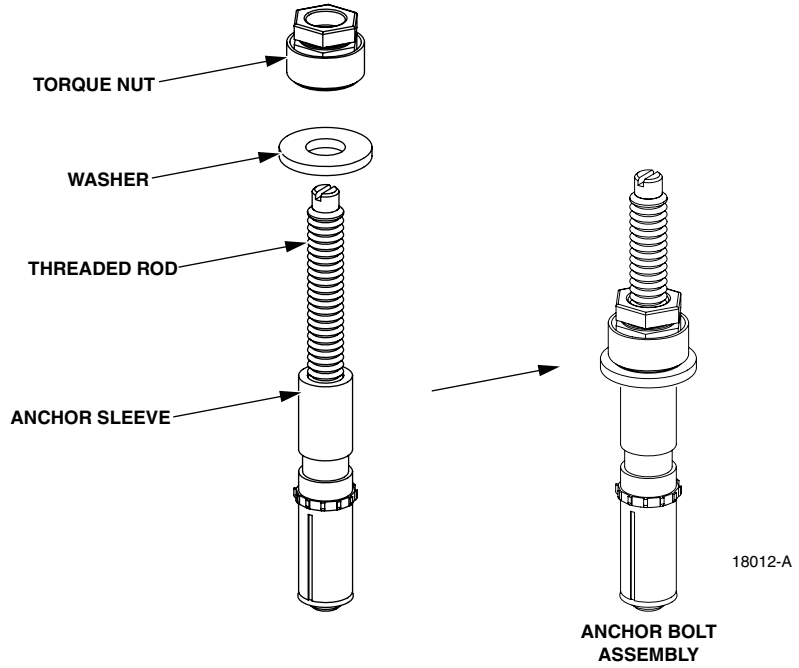

CONCRETE FLOOR INSTALLATION

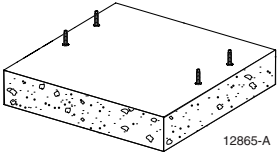

46 INSERT THE ANCHOR BOLT ASSEMBLY INTO THE HOLE.
TAP THE ANCHOR BOLT ASSEMBLY WITH A HAMMER UNTIL THE WASHER TOUCHES THE CONCRETE.

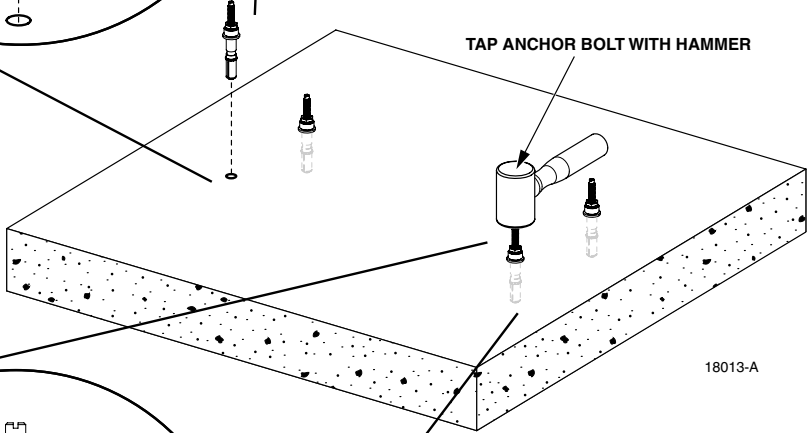
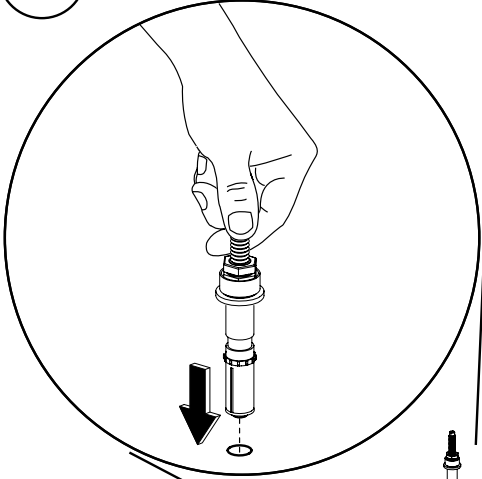

18013-A

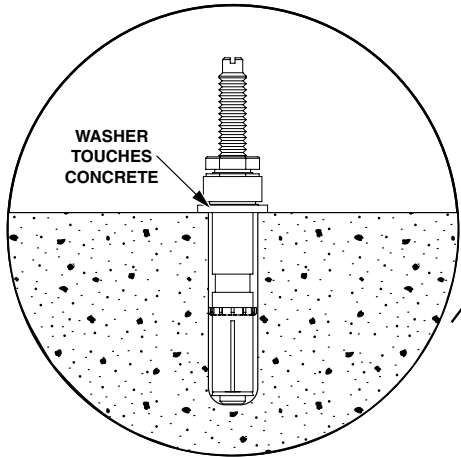

SIDE VIEW

CONCRETE FLOOR INSTALLATION

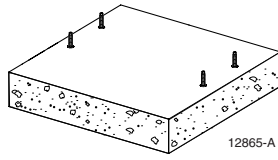

47

USE REFERENCE DIRECTION FROM LABEL INCLUDED ON THE ANCHOR BAG TO INSTALL THE ANCHOR BOLT.

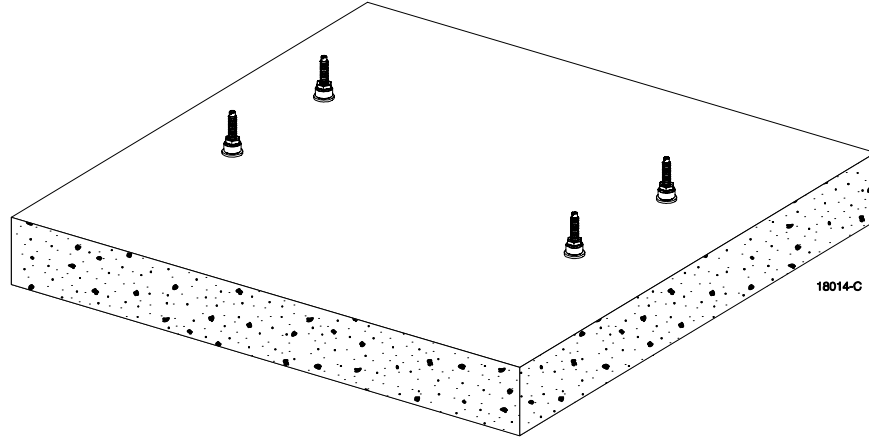

CONCRETE FLOOR INSTALLATION

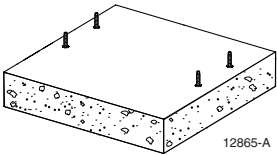

48 LOOSEN THE TORQUE NUT SEVERAL TURNS, THEN REMOVE THE TORQUE NUT AND WASHER.

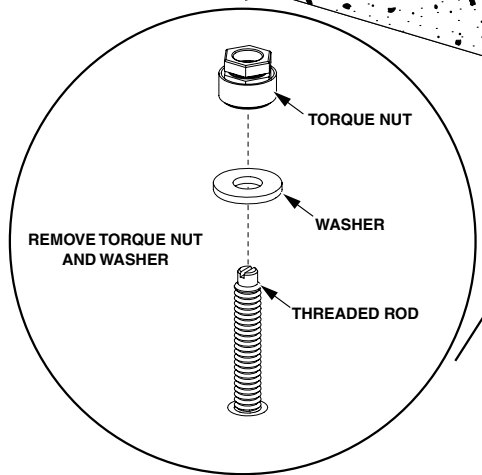
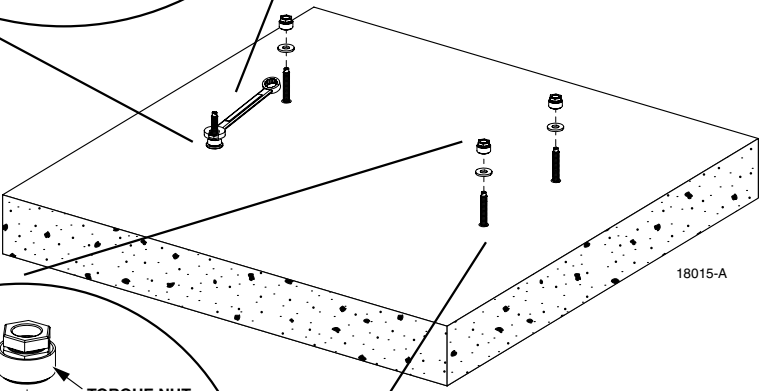
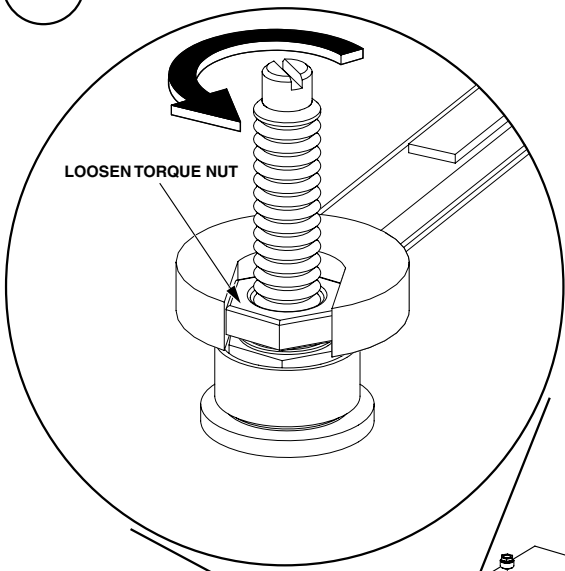

CONCRETE FLOOR INSTALLATION

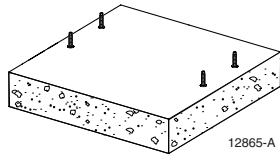

CAUTION: A RACK LOADED WITH PANELS WEIGHS APPROXIMATELY 204.12 KILOS (450 LBS). DO NOT ATTEMPT TO LIFT OR MOVE THE RACK WITHOUT USING APPROPRIATE EQUIPMENT

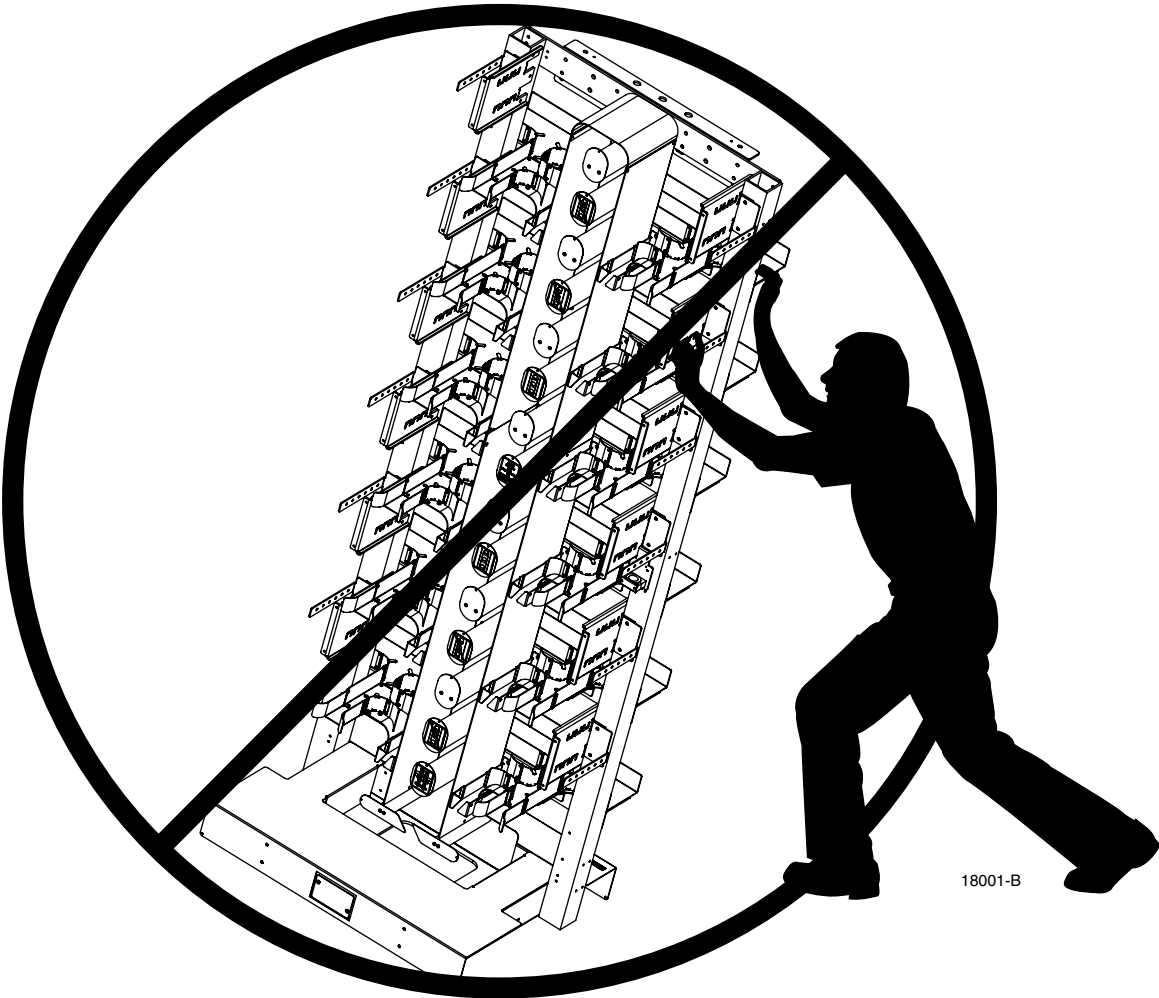

CONCRETE FLOOR INSTALLATION

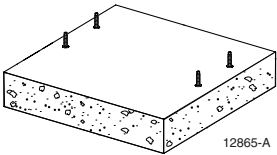

49 REMOVE KICK PLATE TO ACCESS MOUNTING SLOTS IN BASE OF RACK

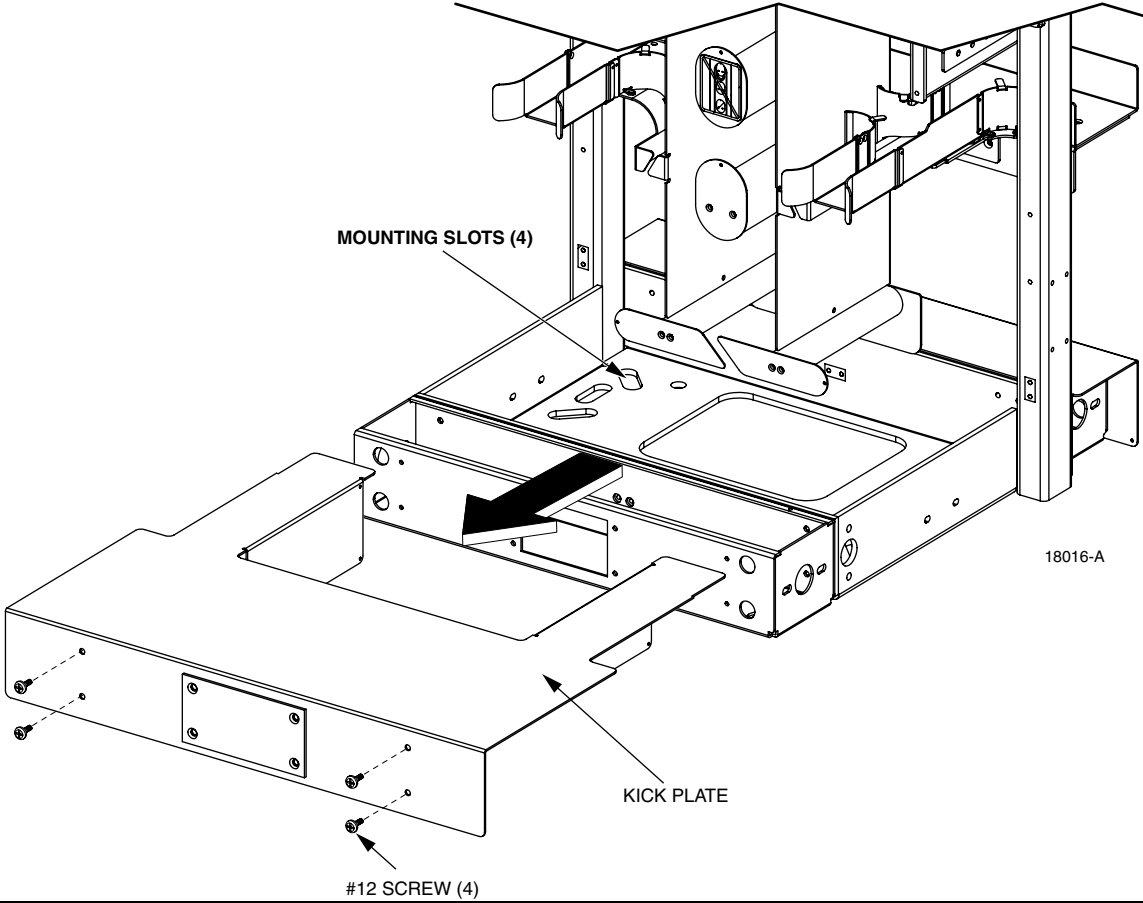

CONCRETE FLOOR INSTALLATION

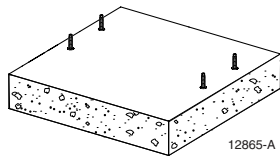

50 POSITION TEMPLATE/ISOLATION PAD AND RACK ON CONCRETE

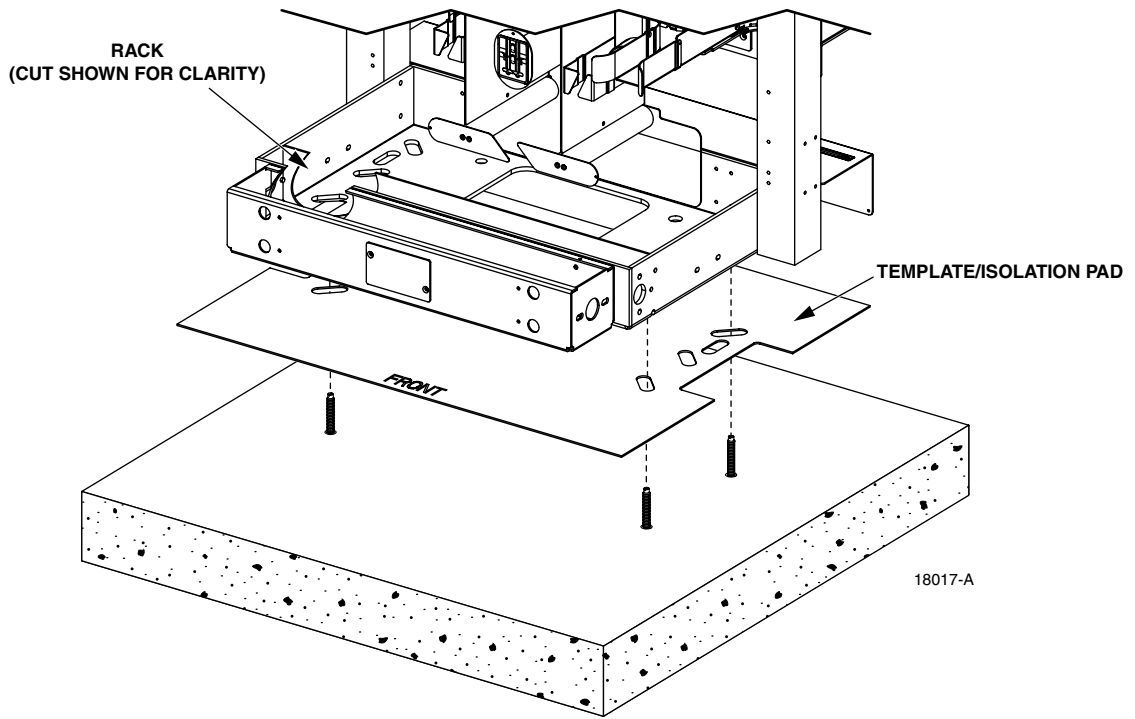

NOTE: USE LEVELING SHIMS (PROVIDED)
TO LEVEL RACK, IF NECESSARY

CONCRETE FLOOR INSTALLATION

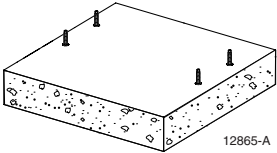

51 ASSEMBLE HARDWARE ONTO THREADED ROD

- TORQUE NUT
- FLAT WASHER
- HOLD DOWN WASHER
- HOLD DOWN PLATE

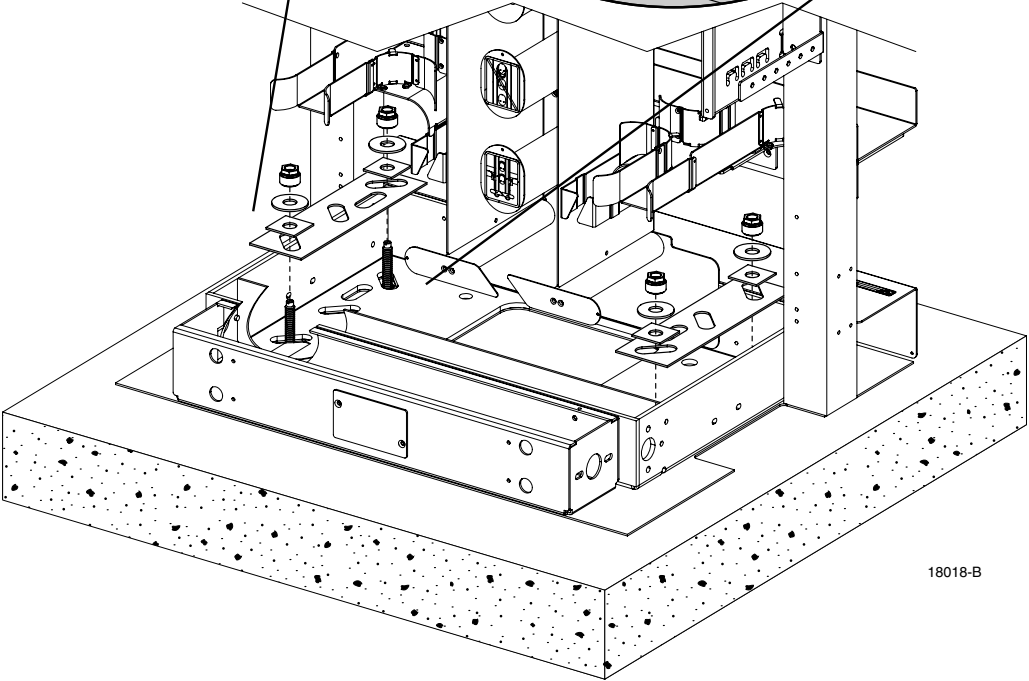
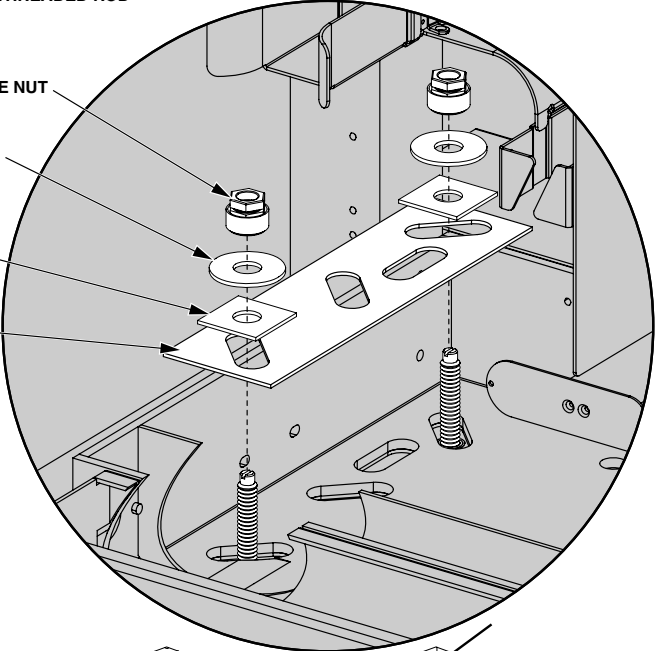

18018-B

CONCRETE FLOOR INSTALLATION

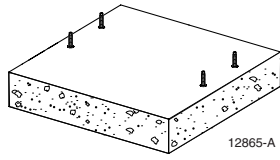

52 TIGHTEN TORQUE NUT UNTIL TOP FLANGE SHEARS OFF (4 PLACES).

NOTE: NOTE: THE TORQUE NUT WILL BE CORRECTLY SET AT 60 FT-LBS (81 N-m) AS INDICATED ON THE LABEL FROM THE ANCHOR BOLT BAG.

SHEAR OFF TOP FLANGE OF TORQUE NUT

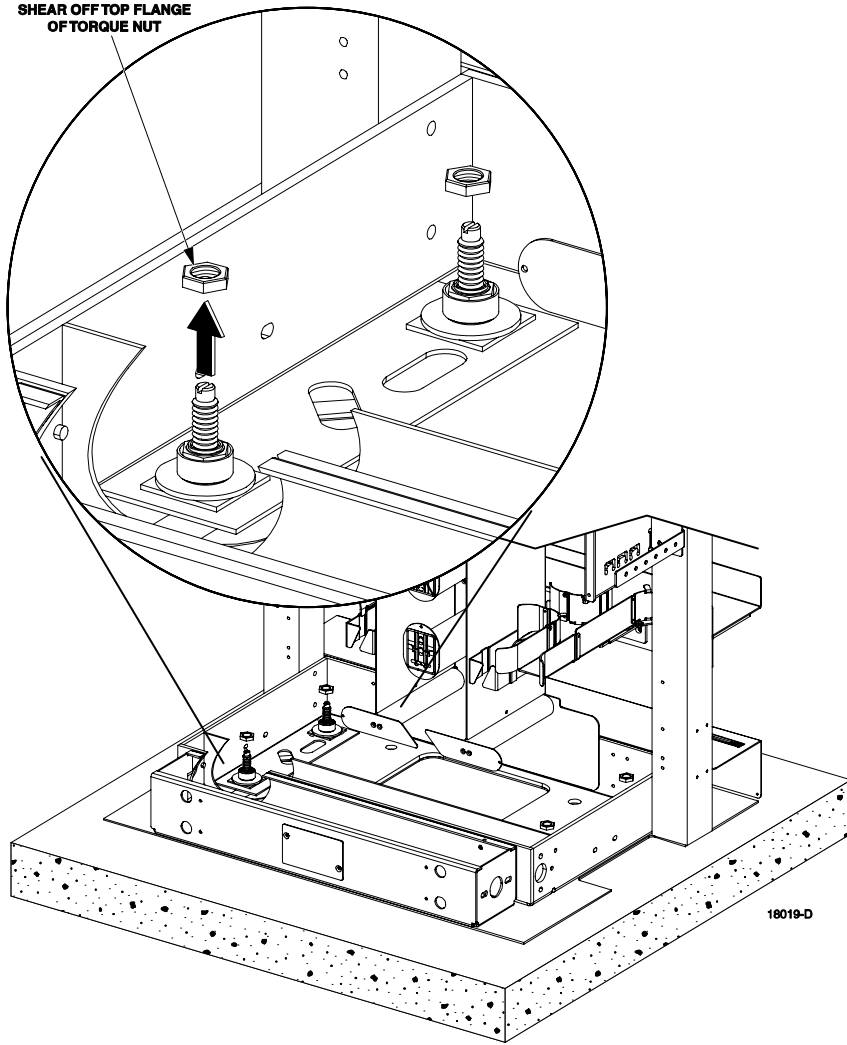

CONCRETE FLOOR INSTALLATION

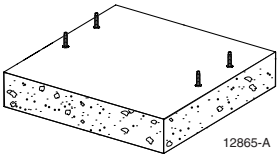

53 RE-INSTALL KICK PLATE

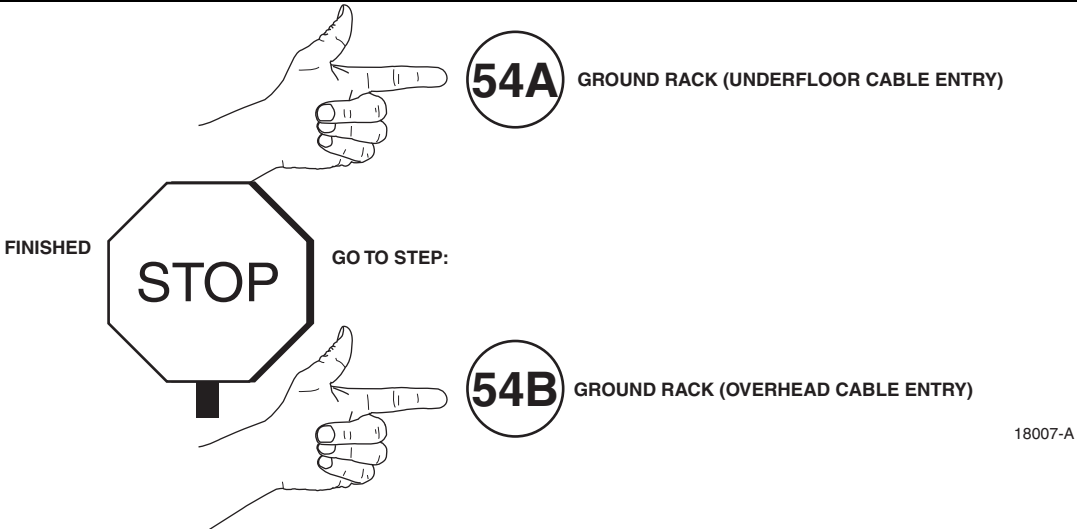
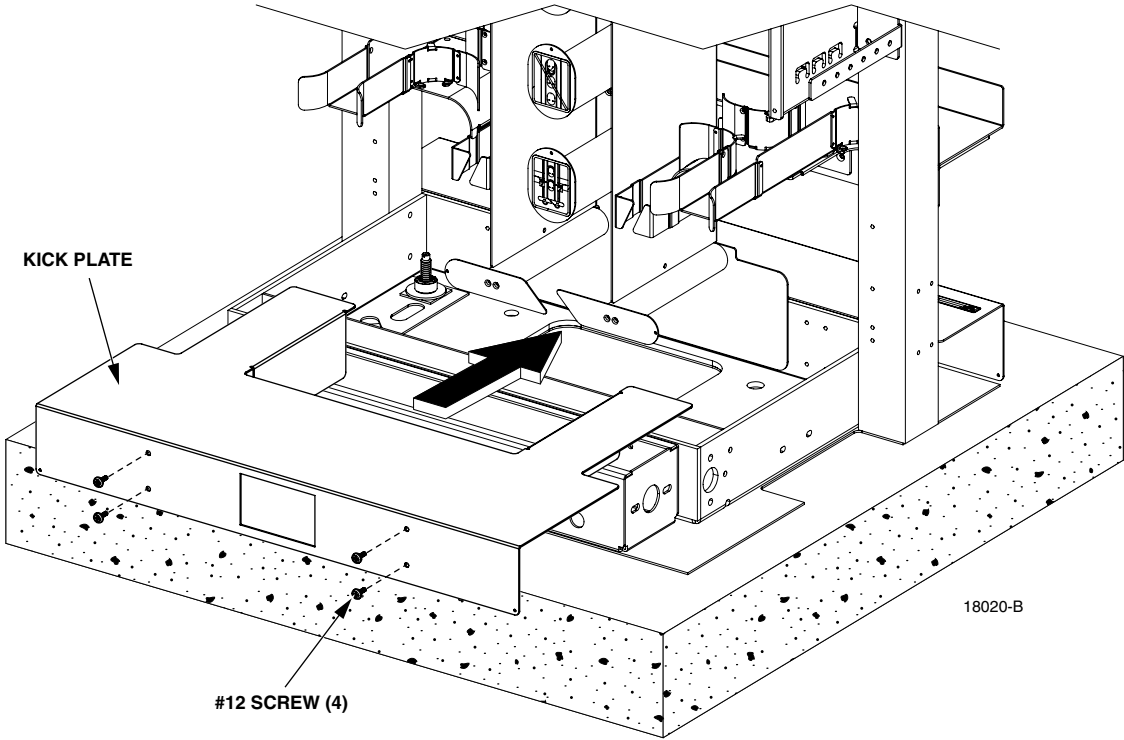

54A GROUND RACK

**NOTE: REMOVE TAPE TO EXPOSE BARE METAL IN GROUNDING LOCATION.
APPLY BONDING COMPOUND TO BARE METAL.**

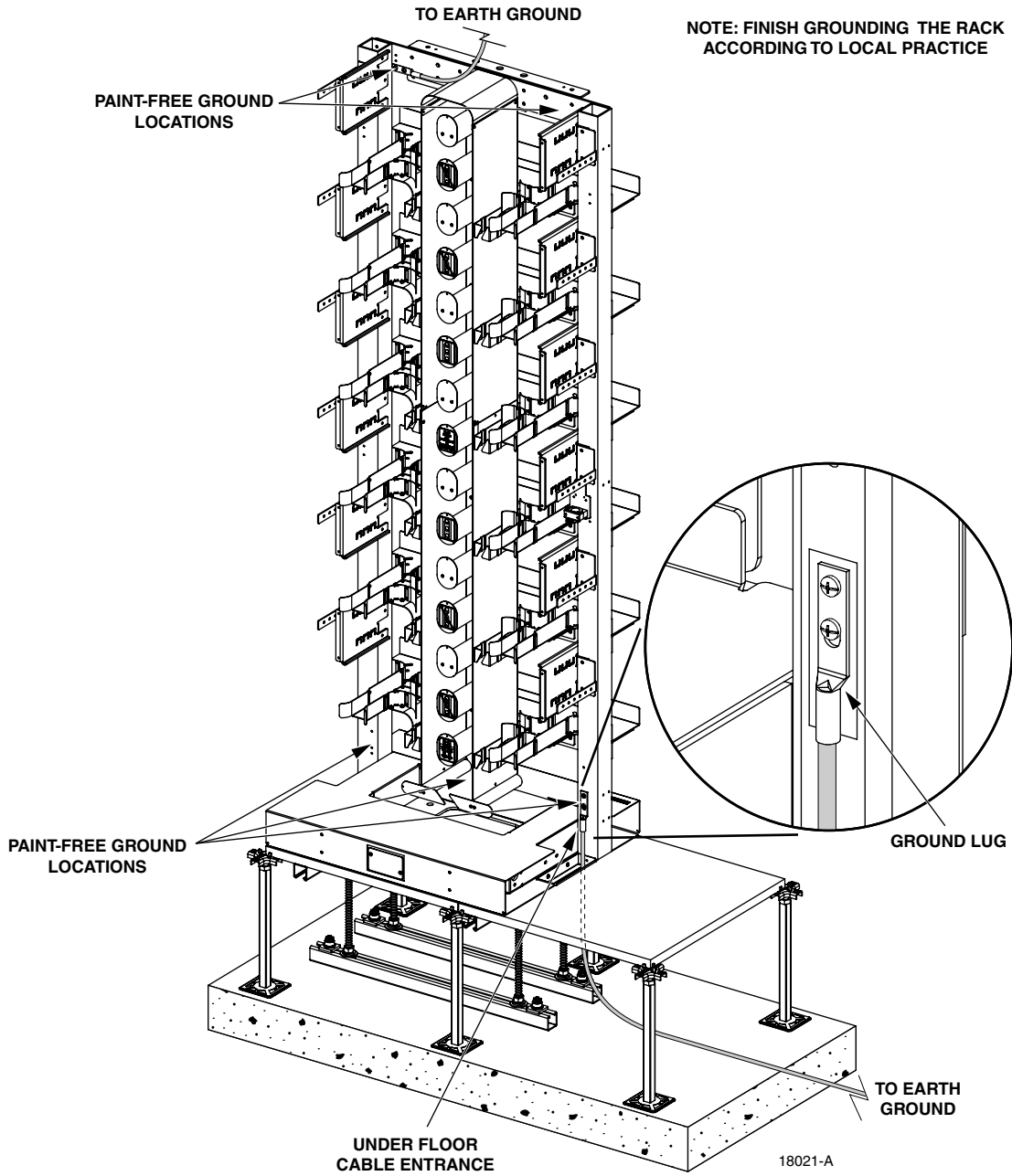

54B GROUND RACK (OVERHEAD CABLE ENTRY)

NOTE: REMOVE TAPE TO EXPOSE BARE METAL IN GROUNDING LOCATION. APPLY BONDING COMPOUND TO BARE METAL.

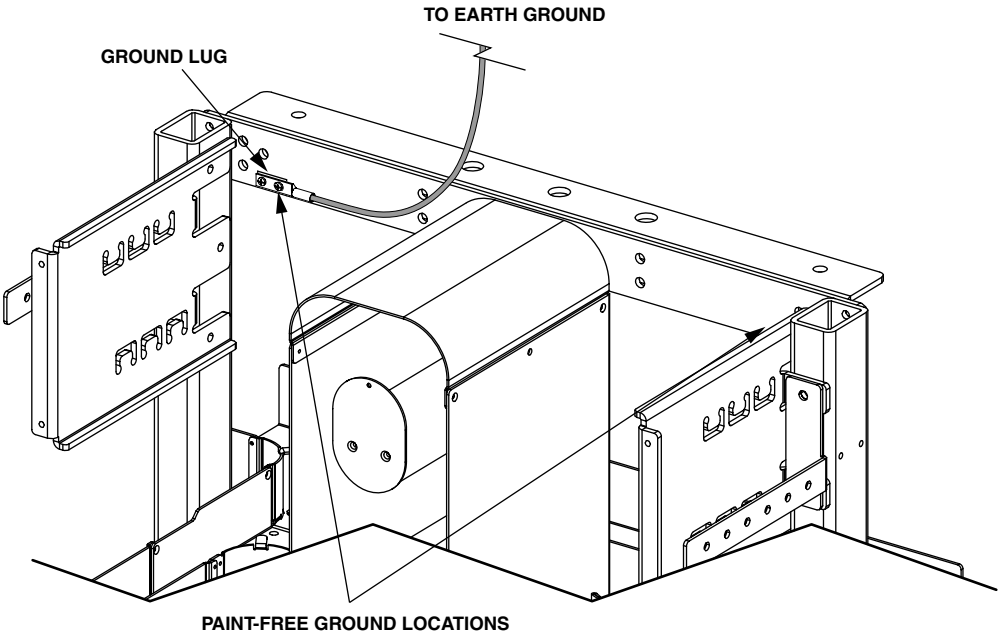

NOTE: FINISH GROUNDING THE RACK ACCORDING TO LOCAL PRACTICE

18022-A

55 LINE UP EXAMPLE

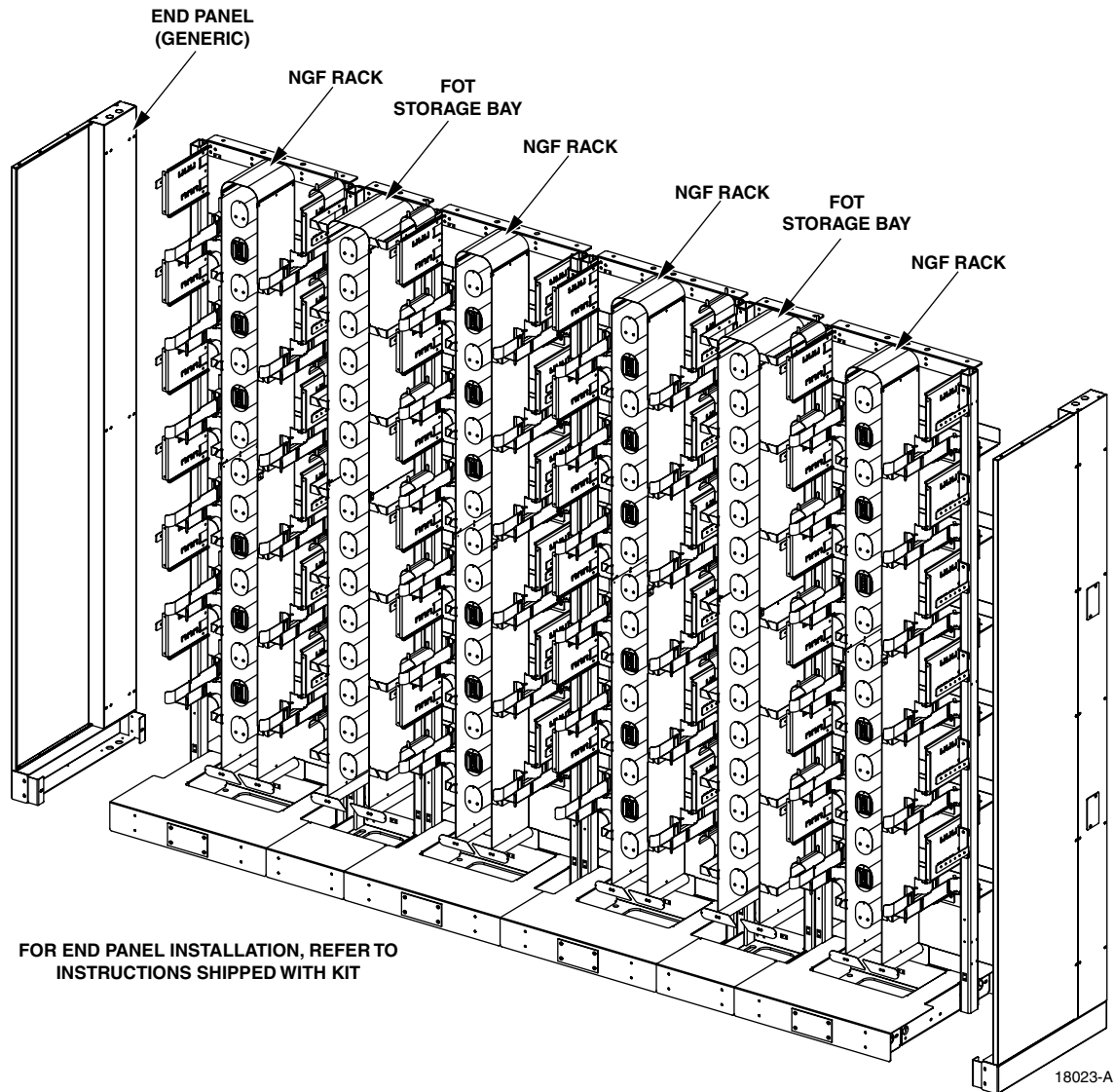

FOR END PANEL INSTALLATION, REFER TO INSTRUCTIONS SHIPPED WITH KIT

18023-A



TECHNICAL ASSISTANCE & PRODUCT INFORMATION
<http://www.commscope.com/SupportCenter>

PRODUCT PATENTS
<http://www.commscope.com/ProductPatent/ProductPatent.aspx>

USER MANUALS
<http://www.commscope.com/SupportCenter>