

REVISIONS			
REV.	DESCRIPTION	DATE	APPROVED
A	ECR 8000014832 : REL TO PRODUCTION PER EAO 602520.	6/23/2016/B.D	MO/OI
B	ECR 8000015610: UPDATE JAHH-65A-R3B	8/12/2016 HG	PL.TANGLIGWU
C	ECR 8000021308: UPDATE DRAWING WITH LATEST MODEL.	23MAR17 HWW	AP/NH
D	ECR 8000033919: REVISION UPGRADE.	01MAR19 YZ	PL.TANG/HANSEN.W
E	ECR 8000036540: UPDATE DRAWING WITH LATEST MODEL.	27JUL19 QF	ZHWJ/REX

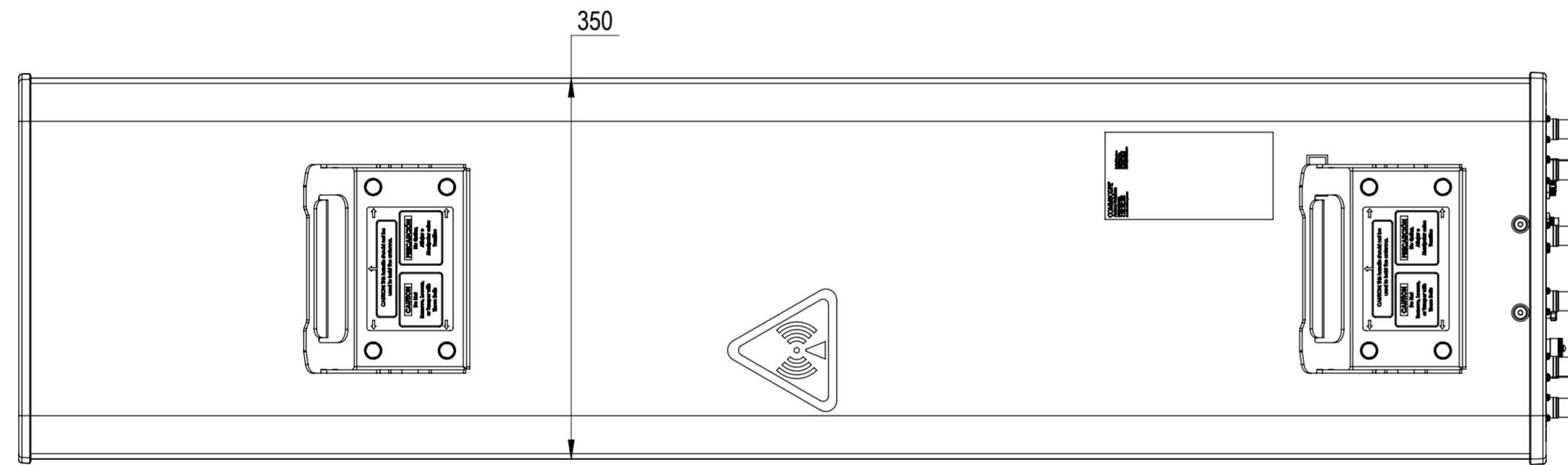
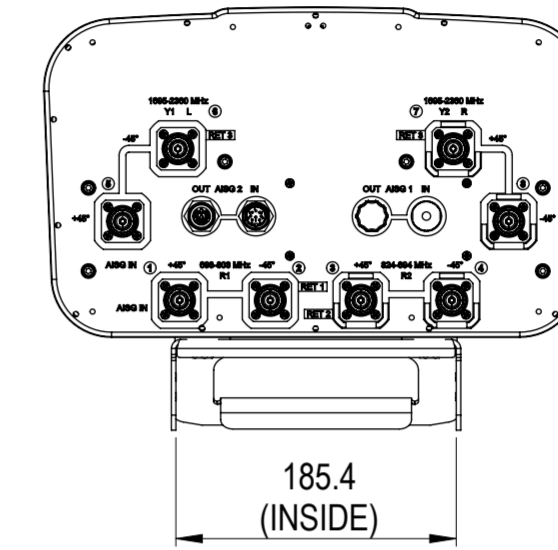
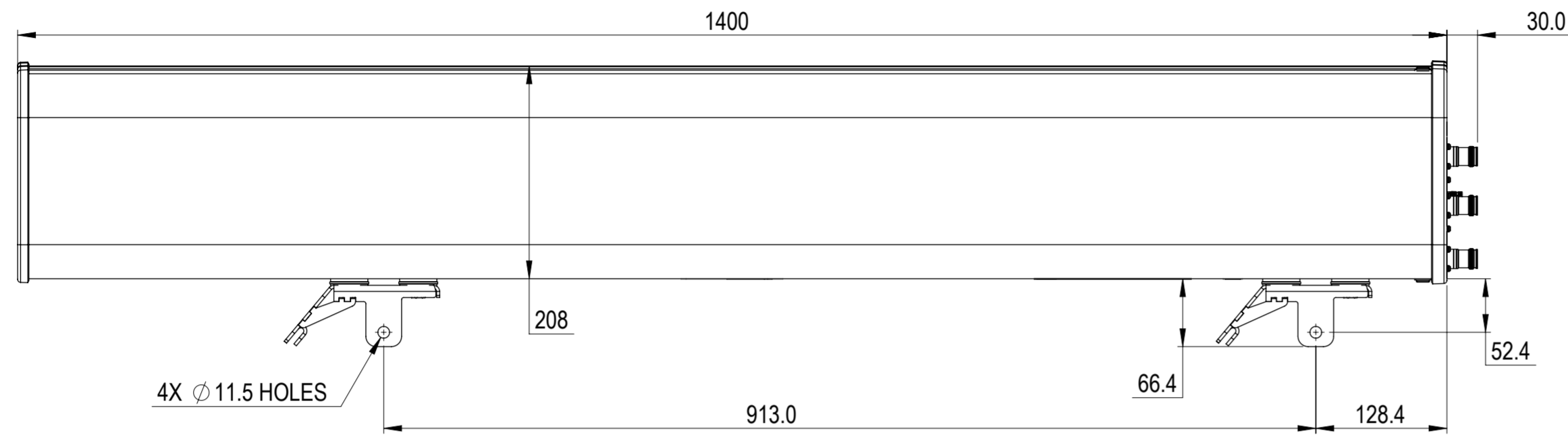

JAHH-65A-R3B

COMMSCOPE, INC. OF NORTH CAROLINA

TOLERANCES		SAP MATERIAL MASTER						
0 PLACE X ±	2 PLACE .XX ±							
1 PLACE .X ±	ANGLES ±							
FINISH		MATERIAL						
<small>UNLESS OTHERWISE SPECIFIED DIMENSIONS ARE IN MILLIMETERS INTERPRET PER ISO STANDARDS HANDBOOK TECHNICAL DRAWINGS VOLUMES 1 & 2, THIRD EDITION (2002)</small>		NAME	DATE					
		CE B.D	6/23/2016					
		RW QW1004	08/05/2019					
		RV WZ1020	08/05/2019					
		AD HC1052	08/05/2019					
RE ZHHCHEN	08/05/2019	SCALE 1:10 DOCUMENT NO. JAHH-65A-R3B-L						
ECN 8000036540-O								
SIZE	WORK AREA	23	MODEL					
A2		VERSION	STATUS	REVISION	DRAWING		SHEET	
		07	RE	H	VERSION	STATUS		REVISION
					04	RE	E	

DENSITY	g/mm ³
MASS	grams
VOLUME	mm ³
SURFACE AREA	mm ²
HEIGHT	
LENGTH	
WIDTH	

© 2016 CommScope, Inc.