

NOTES:

REVISIONS			
REV.	DESCRIPTION	DATE	APPROVED
A	ECR 800007715: REL TO PRODUCTION.	23JUL15 SWD	SHEN.MIN/ZHANG.XU
B	ECR 8000032959: UPDATE DRAWING ERROR.	12DEC18 QF	S.LIU/JIHE

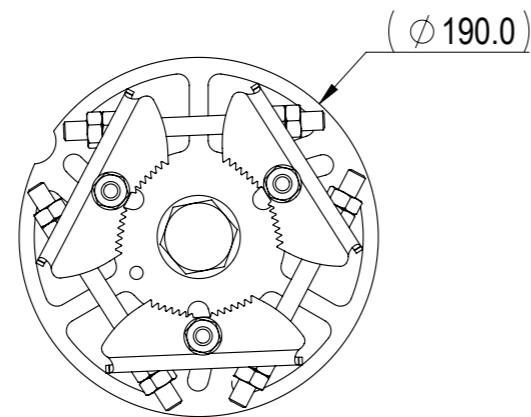
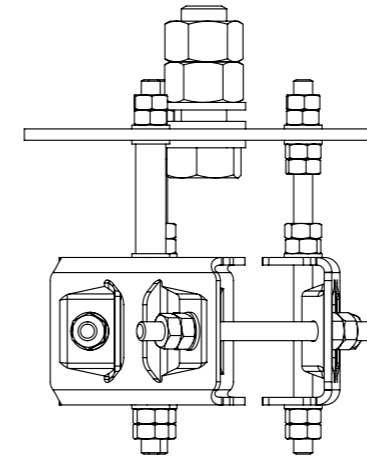
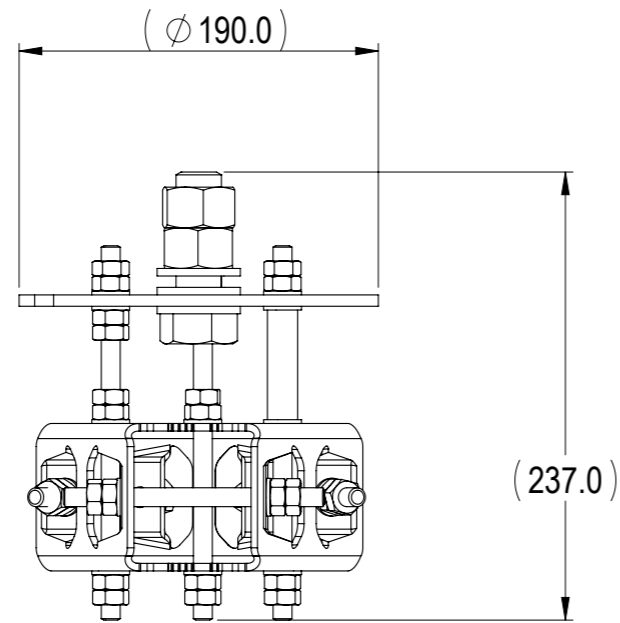

**MC-MNT-3XV-TS1  
TOP MOUNT**

<b>COMMSCOPE, INC. OF NORTH CAROLINA</b>											
TOLERANCES						SAP MATERIAL MASTER					
0 PLACE X ±		2 PLACE .XX ±									
1 PLACE .X ±		ANGLES ±									
FINISH N/A						MATERIAL N/A					
<b>PRODUCT DRAWING</b>											
UNLESS OTHERWISE SPECIFIED DIMENSIONS ARE IN MILLIMETERS INTERPRET PER ISO STANDARDS HANDBOOK TECHNICAL DRAWINGS, VOLUMES 1 & 2, THIRD EDITION (2002)		NAME		DATE		TITLE					
CE SWD		23JUL15		<b>MC-MNT-3XV-TS1-L</b>							
RW QW1004		12/12/2018									
RV CHALIU		12/12/2018									
AD JIHE		12/18/2018									
RE ZHHCHEN		12/19/2018									
ECN 8000032959-O		SCALE		DOCUMENT NO.							
		1:5									
DENSITY		g/mm³		SIZE		WORK AREA		23		MODEL	
MASS		grams		A3		⊕		⊖		DRAWING	
VOLUME		mm³		VERSION		STATUS		REVISION		VERSION	
SURFACE AREA		mm²		00		RE		A		01	
HEIGHT				DRAWING		STATUS		REVISION		VERSION	
LENGTH				00		RE		A		01	
WIDTH				SHEET		STATUS		REVISION		VERSION	
				1 OF 3		RE		B		01	

DENSITY	g/mm³
MASS	grams
VOLUME	mm³
SURFACE AREA	mm²
HEIGHT	
LENGTH	
WIDTH	

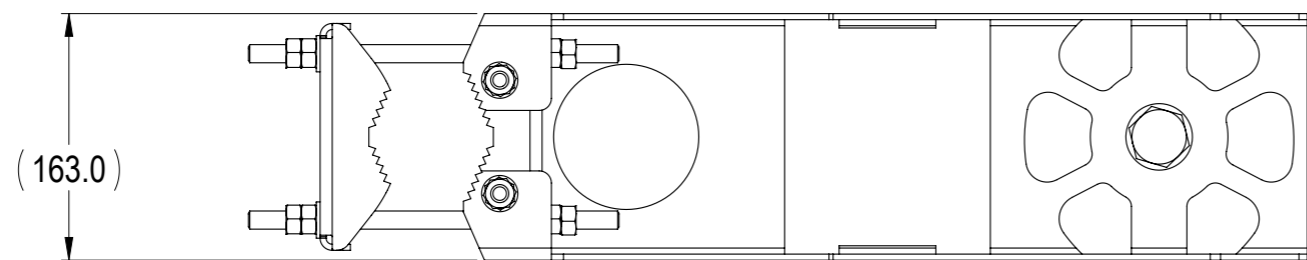
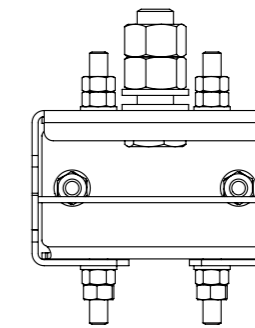
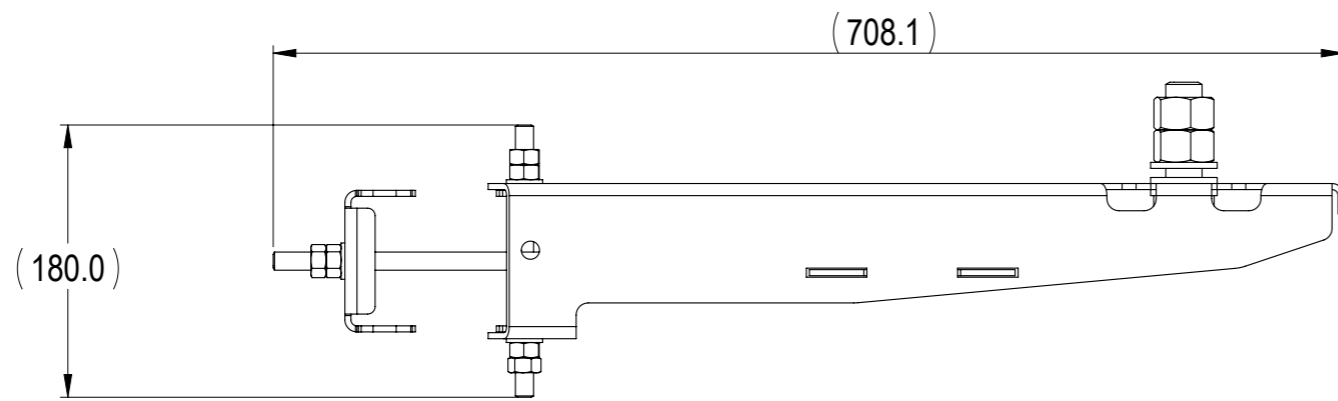

**MC-MNT-3XV-TS1  
SIDE MOUNT OPTION 1**

COMMSCOPE, INC. OF NORTH CAROLINA

TITLE

PRODUCT DRAWING

SIZE

**A3**

SCALE

**1:5**

DOCUMENT NO.

**MC-MNT-3XV-TS1-L**



DRAWING

VERSION

STATUS

REVISION

SHEET

01

RE

B

2 OF 3

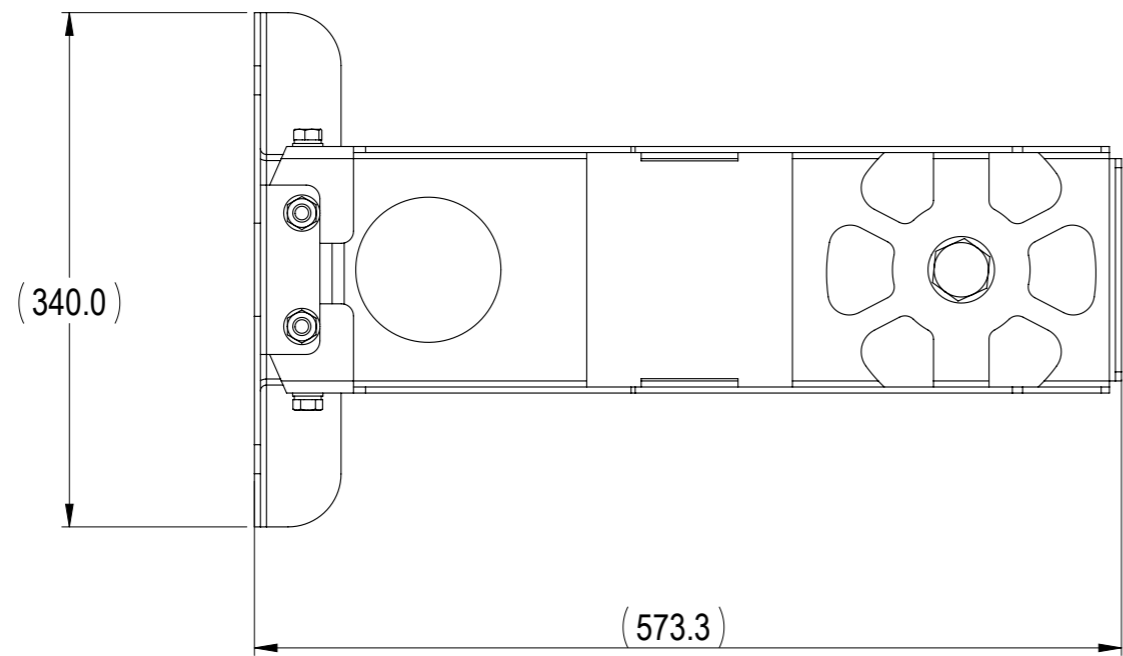
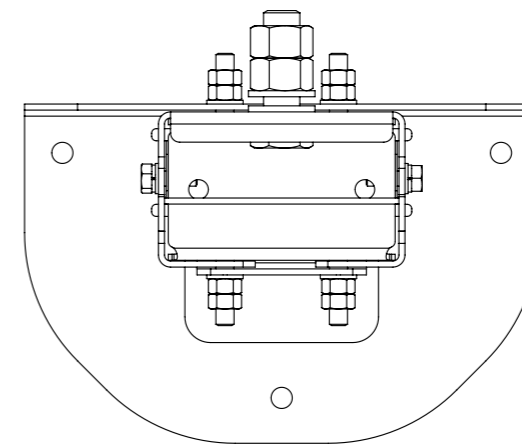
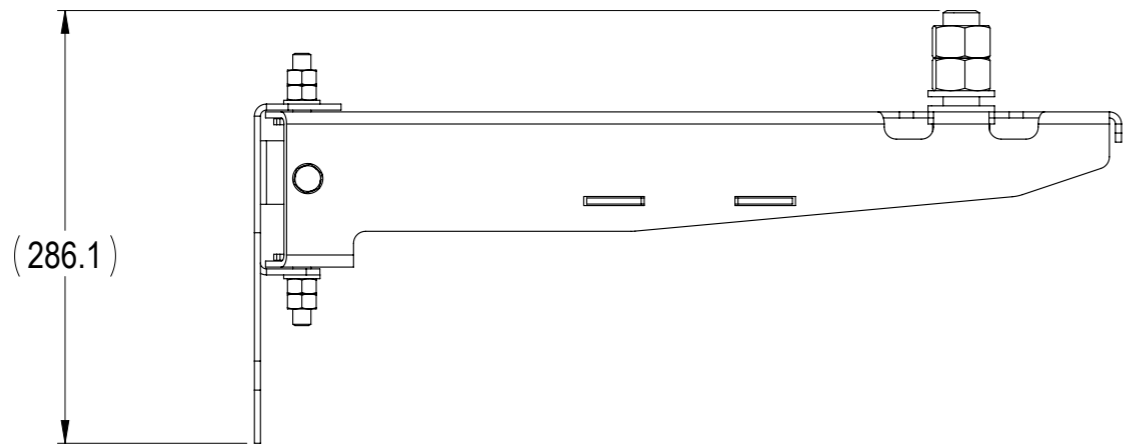

**MC-MNT-3XV-TS1  
SIDE MOUNT OPTION 2**

COMMSCOPE, INC. OF NORTH CAROLINA					
TITLE PRODUCT DRAWING					
SIZE <b>A3</b>	SCALE <b>1:5</b>	DOCUMENT NO. <b>MC-MNT-3XV-TS1-L</b>			
		DRAWING			SHEET 3 OF 3
		VERSION 01	STATUS RE	REVISION B	