

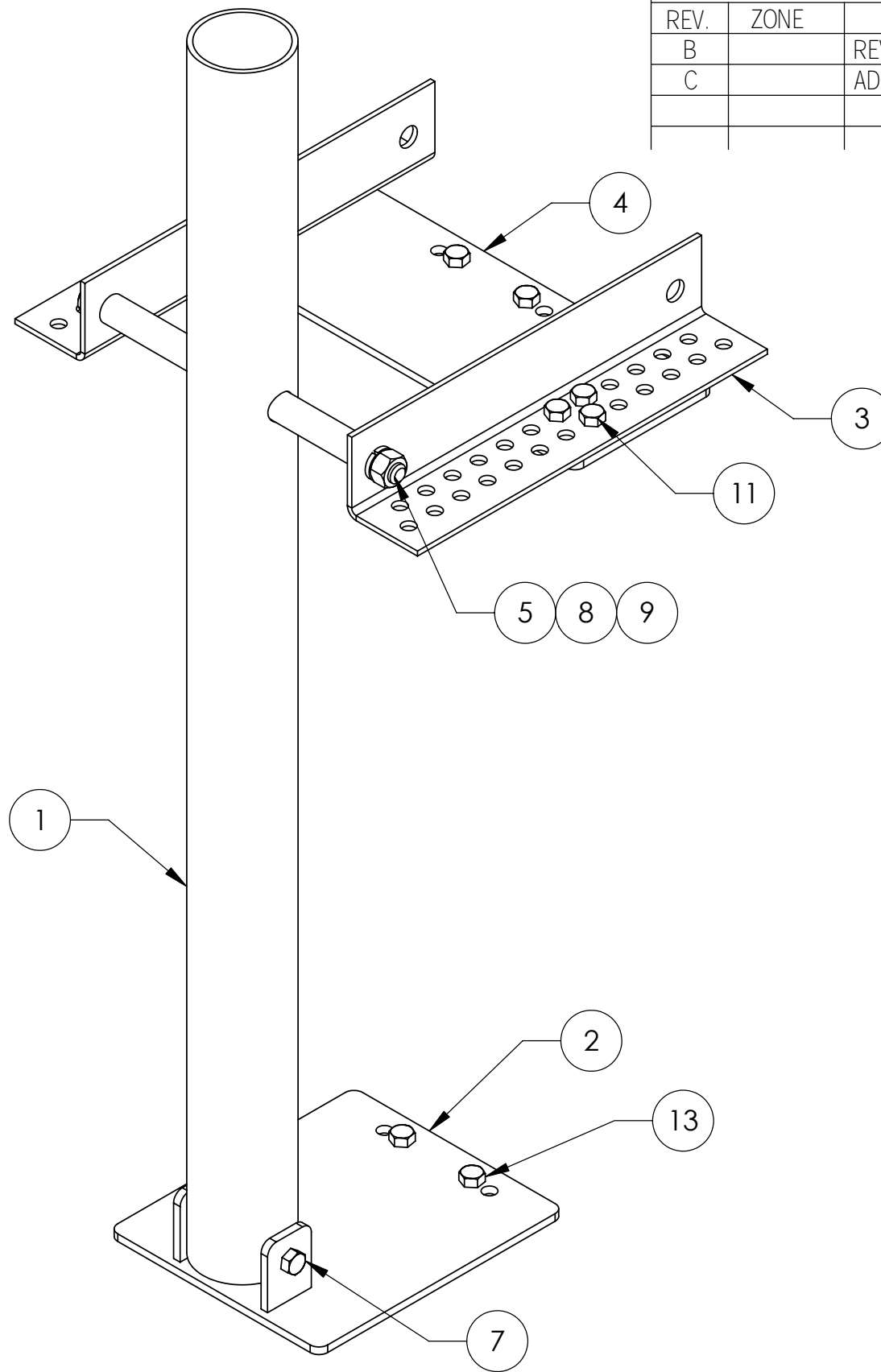

ITEM	PART NO.	DESCRIPTION	QTY.	WEIGHT
1	PMAT41260.01	CENTER SUPPORT WELDMENT	1	56.81 LBS
2	PMAT412.02	BASE WELDMENT	1	19.27 LBS
3	PMAT412.11	UNIVERSAL MOUNTING PLATE	2	9.99 LBS
4	PMAT412.03	TOP PLATE	1	19.11 LBS
5	MT-384-7818	7/8" x 18" GALV THREADED ROD	1	3.05 LBS
6	PM-AT412-H	HARWARE KIT (INCLUDES ITEMS 7-13)	1	-
7	GB-05605	5/8" X 6" GALV BOLT KIT	1	0.22 LBS
8	GWL-07	7/8" GALV LOCK WASHER	2	0.01 LBS
9	GN-07	7/8" GALV HEX NUT	2	0.08 LBS
11	GB05165	5/8" X 1-3/4" GALV BOLT KIT	6	0.22 LBS
12	MT-395H	HARDWARE KIT ITEM # 13	1	
13	GB-0516A	5/8" X 1-3/4" GALV BOLT KIT A325	4	0.22 LBS

REVISIONS				
REV.	ZONE	DESCRIPTION	BY	DATE
B		REVISED	DI	1/26/05
C		ADDED MT- 395H	AW	9/06/06



<p>These drawings and specifications are the proprietary property of ANDREW CORPORATION and may be used only for the specific purpose authorized in writing by Andrew Corporation.</p> <p>ALL DIMENSIONS ARE IN INCHES U.O.S. TOLERANCES UNLESS OTHERWISE SPECIFIED: .X = ± .06 ANGLES ±2° .XX = ± .03 FRACTIONS ±1/32 .XXX = ± .010</p> <p>REMOVE BURRS AND BREAK EDGES .005</p> <p>DO NOT SCALE THIS PRINT</p>	DRAWN BY: DI	SHEET: 1 of 1	PART NUMBER: PM-AT412-60
	CHECKED BY: TP	SCALE: NTS	DESCRIPTION: ADJUSTABLE PIPE MOUNT
	DATE: 1/26/05	MATERIAL: A36, A53	DRAWING TYPE: ASSEMBLY DRAWING
	REVISION: C	FINISH: GALV A123	 ORLAND PARK, IL. 60462 U.S.A.
		WEIGHT: 121.86 LBS	