

- 1.0 GENERAL NOTES
 1.1 ALL METRIC DIMENSIONS ARE IN BRACKETS [X. X]
 1.2 FOR PATENT INFO: <https://www.cs-pat.com>
- 2.0 DESIGN NOTES
 2.1 ANY HAZARDS OR OBSTRUCTIONS TO THE CLIMBING FACILITY AND SAFETY CLIMB MUST BE IDENTIFIED PRIOR TO INSTALLING THE APPURTENANCE. ADDITIONAL PRODUCTS MAY BE REQUIRED TO MAINTAIN THE INTEGRITY OF THE SAFETY CLIMB. DURING INSTALLATION, TEMPORARY AND/OR PERMANENT PRECAUTIONARY MEASURES SHOULD BE TAKEN TO PRESERVE THE CLIMBING FACILITY AND/OR SAFETY CLIMB.
 2.2 UP TO 5.7° TAPER AVAILABLE ON MODELS THAT SUPPORT ADJUSTMENT.
- 3.0 MANUFACTURING/SPECIAL REQUIREMENTS
 3.1 TIGHTEN ALL BOLTS SECURING FLAT PLATES BY THE TURN-OF-NUT METHOD. TIGHTEN ALL U-BOLTS USING TURN-OF-NUT METHOD WITH ATTENTION TO LEAVE EQUAL DISTANCE AND EQUAL FORCE ON EACH LEG OF THE U-BOLT.
- 4.0 TEST
- 5.0 PACKAGING
 5.1 PACKAGING SHALL MEET COMMScope REQUIREMENTS PER DOCUMENT IS-PL-3005.
 5.2 PRINTED DOCUMENT TO BE PLACED INSIDE POLYBAG AND THEN IN SHIPPING CONTAINER.
 5.3 EXTRA HARDWARE MAY BE SUPPLIED, BAGGED AND SHIPPED.

REVISIONS			
REV.	DESCRIPTION	DATE	APPROVED
C	SHEET 1: REMOVED NOTE 3.1; REMOVED MATERIAL AND FINISH TITLE BLOCK ; REMOVED PACKING VIEW FROM SEPARATE DRAWING; ADDED NOTE 2.2; SHEET 2: UPDATED BOM NOTES	YX1027 10/14/2022	40158396CMO
D	TIE BACK PIPES TO FACE PIPES CONNECTION REPLACED XA WITH XP-R	YX1027 12/1/2022	40161600CMO
E	ADDED SHEET 2; ITEM 24 WAS SFG2251; MOVED LOCATION OF ITEM 24 TO THE TOP OF V-ARM; ADDED NOTE FOR POLES DIAMETER IN DETAIL B	RY1002 29AUG23	YW1045 40177837CMO
F	SHEET2: ADDED SFG2152 TO TABLE 1; SHEET5: ADDED LABEL INSTALLATION NOTICE	JL1183 20NOV23	YW1045 40183325CMO
G	CHG PALLET FROM 60X32SFGPALLET TO 48X32PALLET TO MATCH WITH SAP BOM	RY1002 02JUL24	BCROSS 40199404CMO

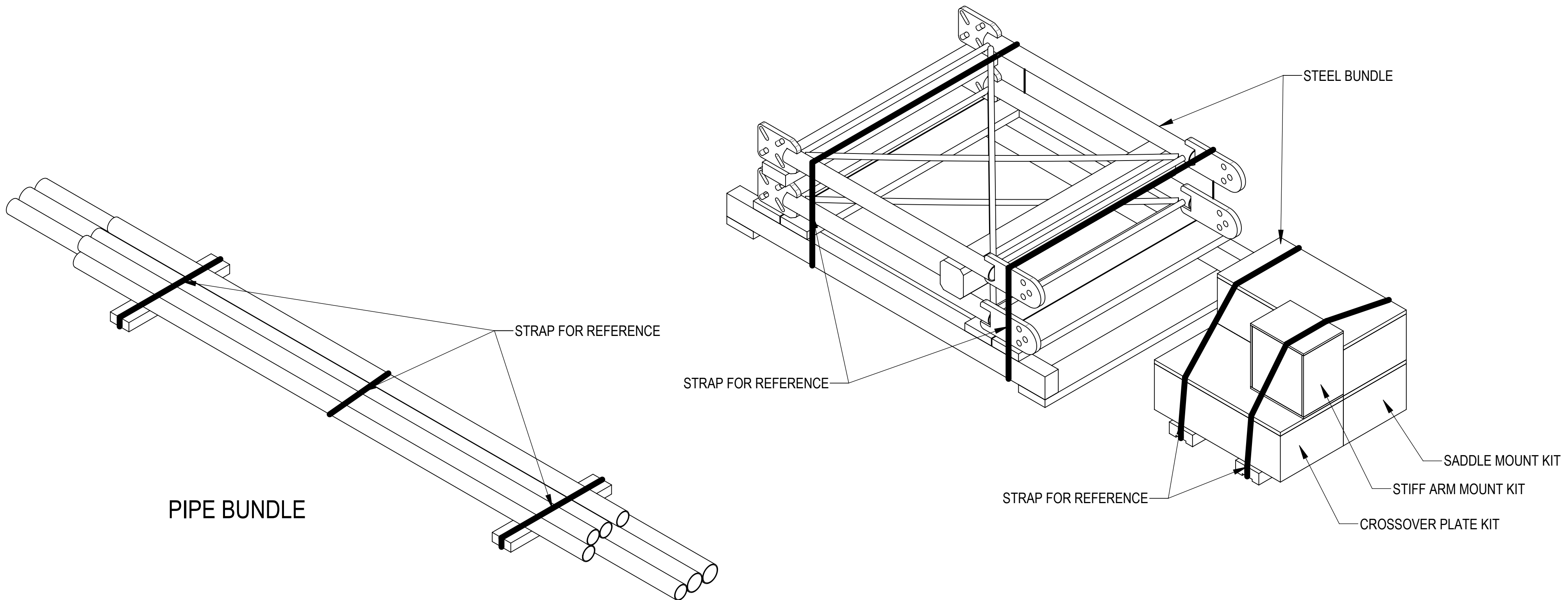

COMMScope, INC. OF NORTH CAROLINA									
TOLERANCES					SAP MATERIAL MASTER				
0 PLACE .X[X] ± 0.25[6.3]		2 PLACE .XX[X] ± 0.06[1.5]			SEE TABLE 1				
1 PLACE .X[X] ± 0.12[3.0]		ANGLES ± 2°							
FINISH					MATERIAL				
UNLESS OTHERWISE SPECIFIED DIMENSIONS ARE IN INCHES INTERPRET PER ANSI Y 14.5M-1994	NAME	DATE	TITLE						
	CE YX1027	4/12/2022	SECTOR FRAME - SFG21HD						
	RW RY1002	07/02/2024							
	AD YMENG	07/08/2024							
	RE YMENG	07/09/2024							
ECN 40199404CMO									
SCALE	DOCUMENT NO.								
1:12	SFG21HD								
SIZE	Auth Group	INSL	MODEL			DRAWING			
C			VERSION	STATUS	REVISION	VERSION	STATUS	REVISION	SHEET
			03	RE	D	07	RE	G	1 OF 8

DENSITY	lbs/in ³
MASS	lbs
VOLUME	in ³
SURFACE AREA	in ²
HEIGHT	
LENGTH	
WIDTH	

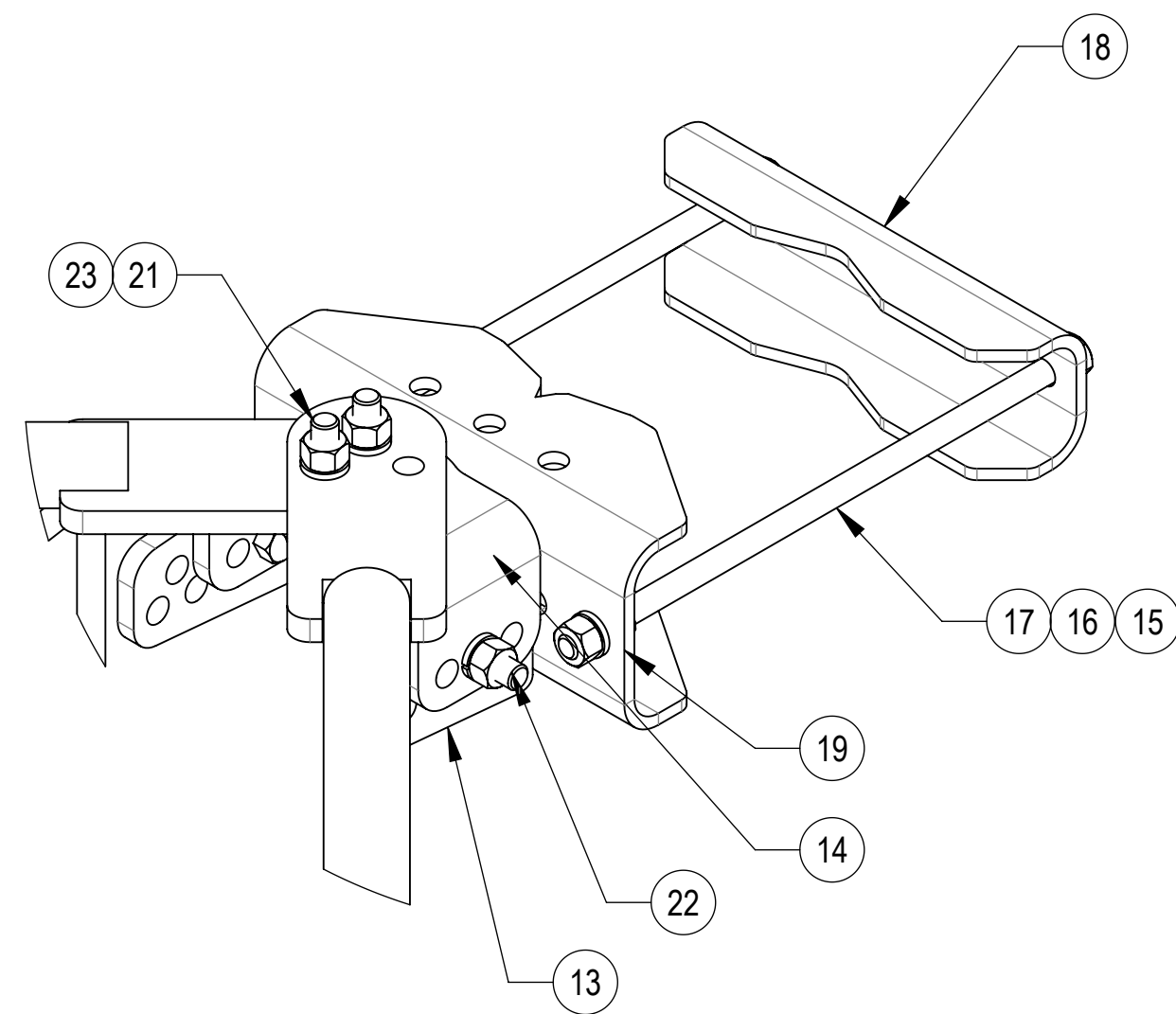

DETAIL A
SCALE 1 : 4

SFG21HD-10-4-96 SHOWN FOR REFERENCE
(NOT ALL CONFIGURATIONS INCLUDE ALL ITEMS SEE NOTES IN TABLE)

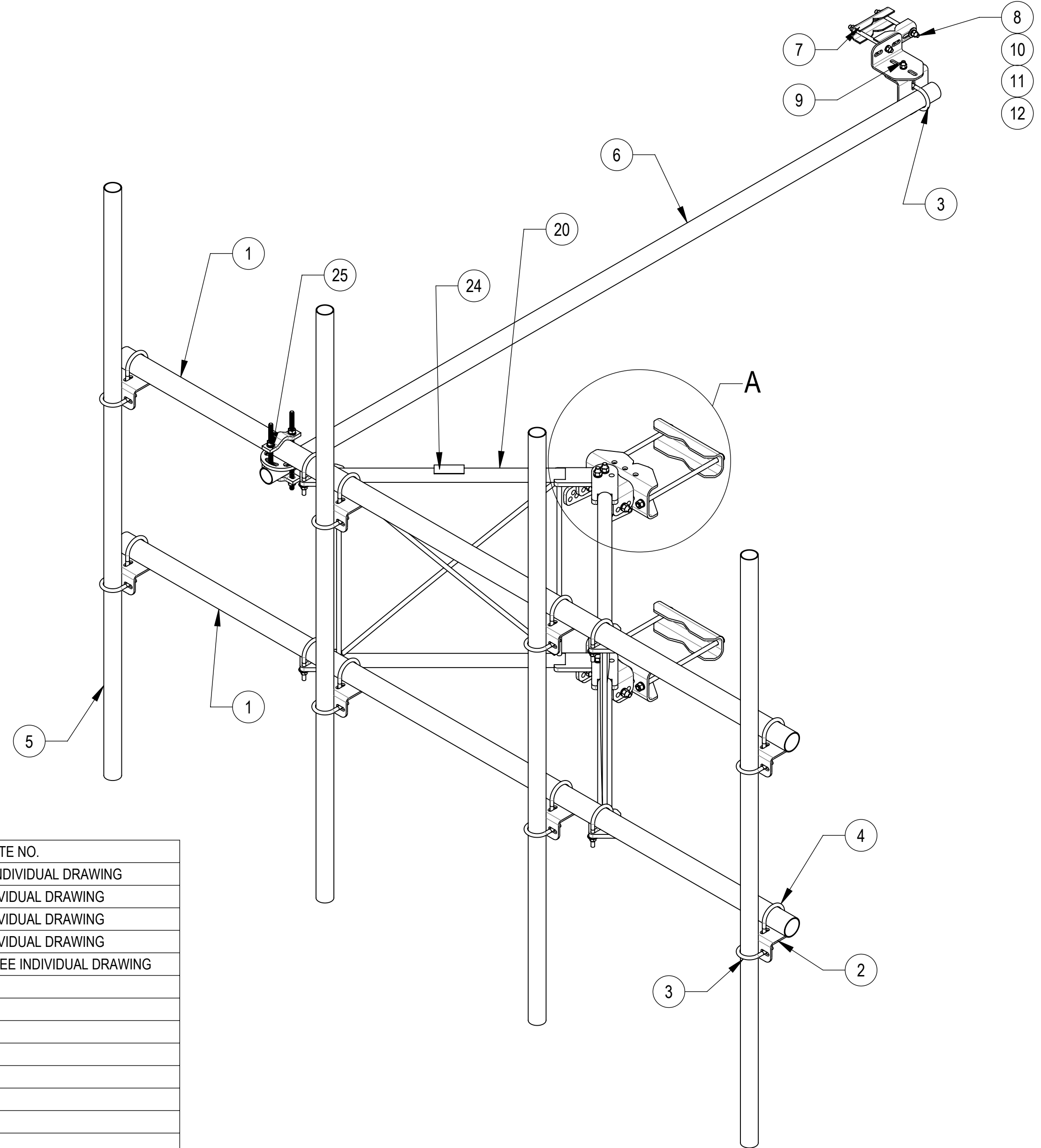

COMPONENT PART NUMBERS PROVIDED FOR ASSEMBLY PURPOSES;
INDIVIDUAL COMPONENTS MAY BE SHIPPED AS PARTS WITHIN AN INCLUDED KIT.

ITEM NO.	PART NUMBER	DESCRIPTION	QTY.	WEIGHT	NOTE NO.
1	MT546126120	PIPE, 2.875"OD X 126"	2	37.21 LBS	PART NO. SEE INDIVIDUAL DRAWING
2	XAU01	ANGLE, CROSSOVER, 1.9-3.5" X 1.9-3.5" OD	10	2.98 LBS	QTY SEE INDIVIDUAL DRAWING
3	GUB-4240	1/2" X 2-1/2" X 4" GALV U-BOLT	9	0.56 LBS	QTY SEE INDIVIDUAL DRAWING
4	GUB-4352	1/2" X 3" X 5-1/4" GALV U-BOLT	12	0.71 LBS	QTY SEE INDIVIDUAL DRAWING
5	MT-651-96	2.375" OD X 96" PIPE	4	23.05 LBS	PART NO. AND QTY SEE INDIVIDUAL DRAWING
6	MT-537	Ø 2.375" OD X 126" PIPE	1	30.45 LBS	
7	SAB01	FORMED CLAMP	2	1.35 LBS	
8	MT-379-8	1/2" X 8" GALV THREADED ROD	2	0.45 LBS	
9	GB-04145	1/2" X 1-1/2" GALV BOLT KIT	1	0.13 LBS	
10	GWF-04	1/2" GALV FLAT WASHER	4	0.04 LBS	
11	GWL-04	1/2" GALV LOCK WASHER	5	0.01 LBS	
12	GN-04	1/2" GALV HEX NUT	5	0.04 LBS	
13	SFV03	SFV TAPER BRACKET	1	7.49 LBS	
14	SFV02	SFV AZIMUTH BRACKET	3	5.91 LBS	
15	GN-05	5/8" GALV HEX NUT	12	0.08 LBS	
16	GWL-05	5/8" GALV LOCK WASHER	8	0.03 LBS	
17	MT-382-16	5/8" X 16" THREADED ROD	4	1.28 LBS	
18	MTC397521	CLAMP, BACK	2	6.94 LBS	
19	MTC397522	CLAMP, FRONT MOUNTING	2	10.02 LBS	
20	SFV01	WELDMENT, SF-V STANDOFF ARM	2	38.31 LBS	
21	GB-05305	5/8" X 3" GALV BOLT KIT	4	0.35 LBS	
22	GB-05225	5/8" X 2-1/4" GALV BOLT KIT	8	0.28 LBS	
23	GWF-05	5/8" GALV FLAT WASHER, 1.70D	6	0.06 LBS	
24	SFG2152	LABEL, SFG21HD	1	0.04 LBS	
25	XP-R	CROSSOVER PLATE, ROUND, UP TO 3.5" OD	1	6.20 LBS	

COMMSCOPE, INC. OF NORTH CAROLINA				
TITLE SECTOR FRAME - SFG21HD				
SIZE C	SCALE 1:16	DOCUMENT NO. SFG21HD		
DRAWING		VERSION	STATUS	REVISION
		07	RE	G
				SHEET 3 OF 8

4

3

2

1

ALLOWABLE TIEBACK ANGLE

±15 DEGREES VERTICAL
±25 DEGREES HORIZONTAL

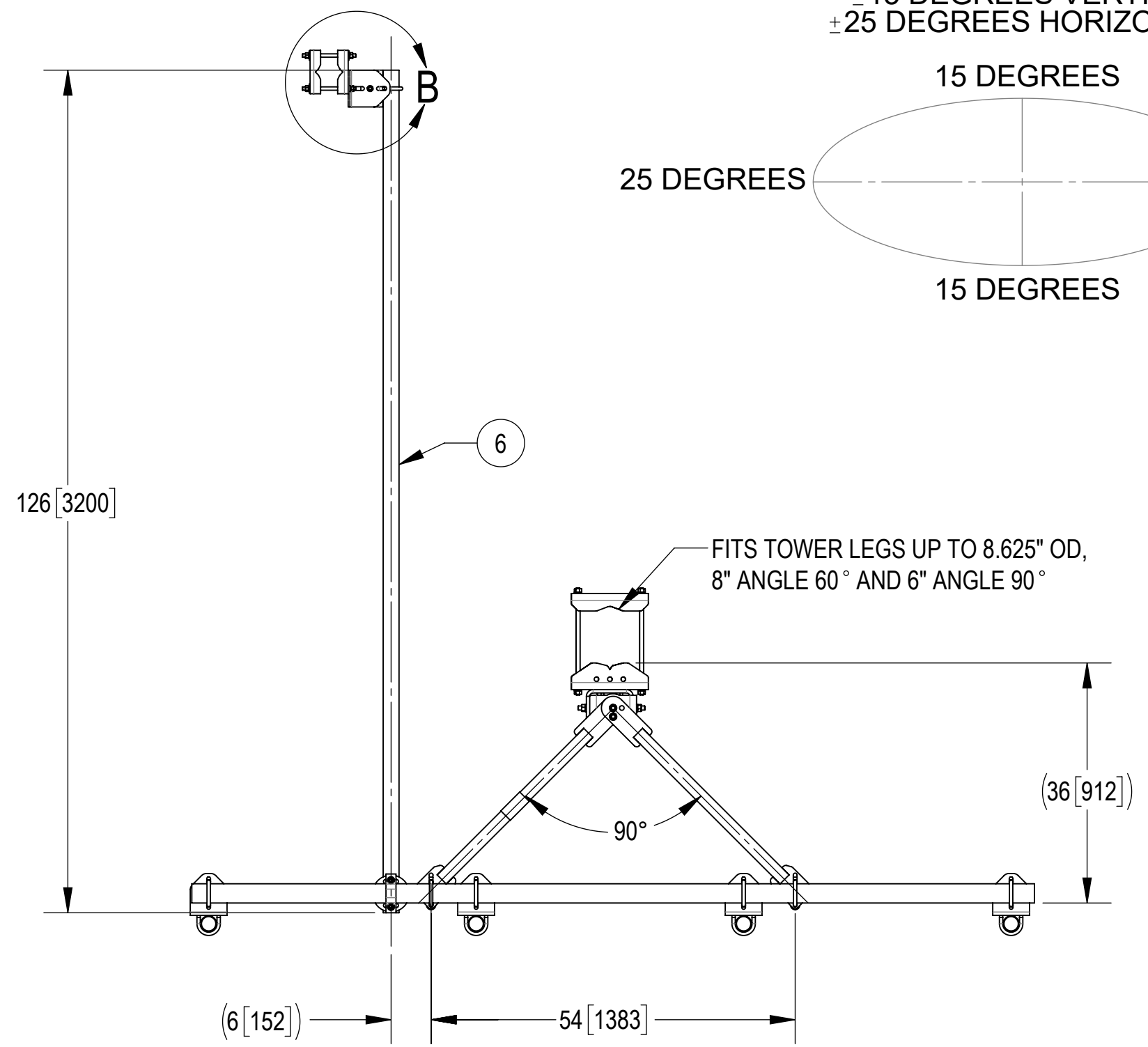
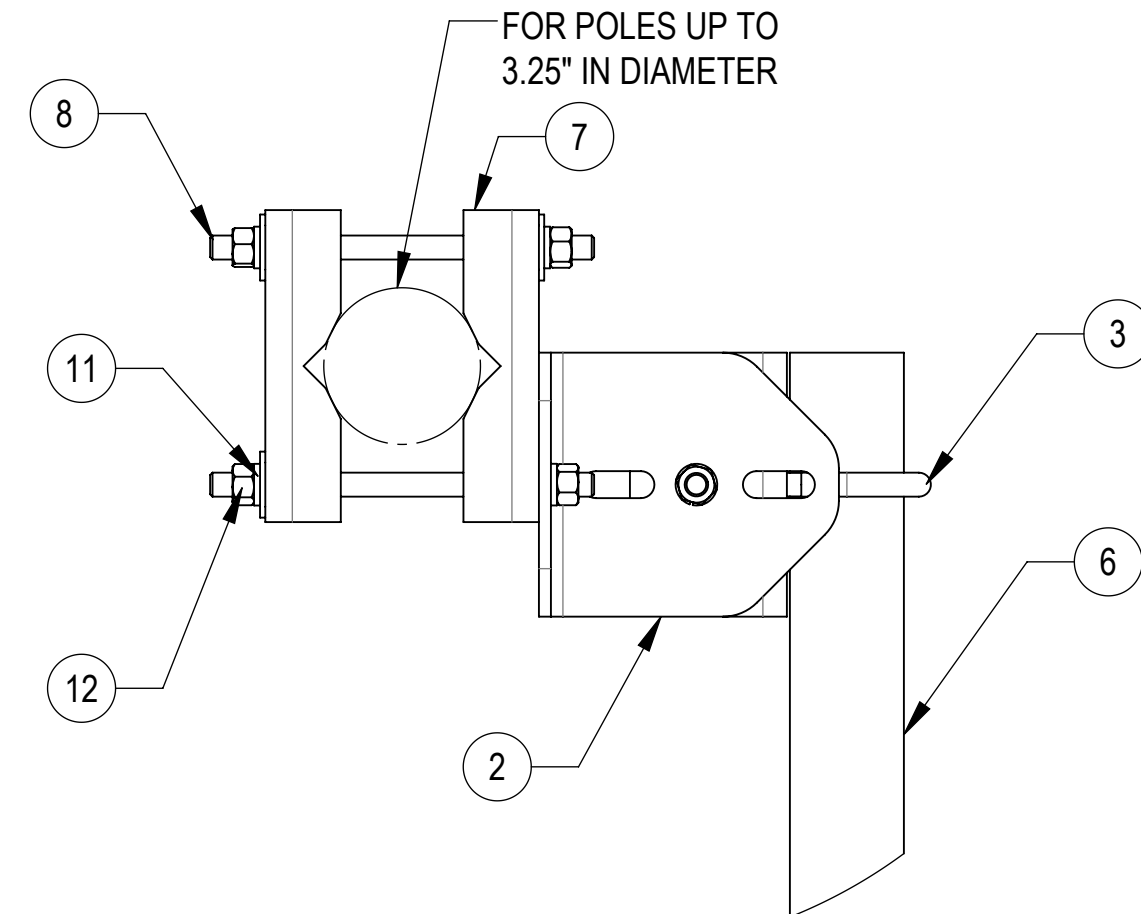
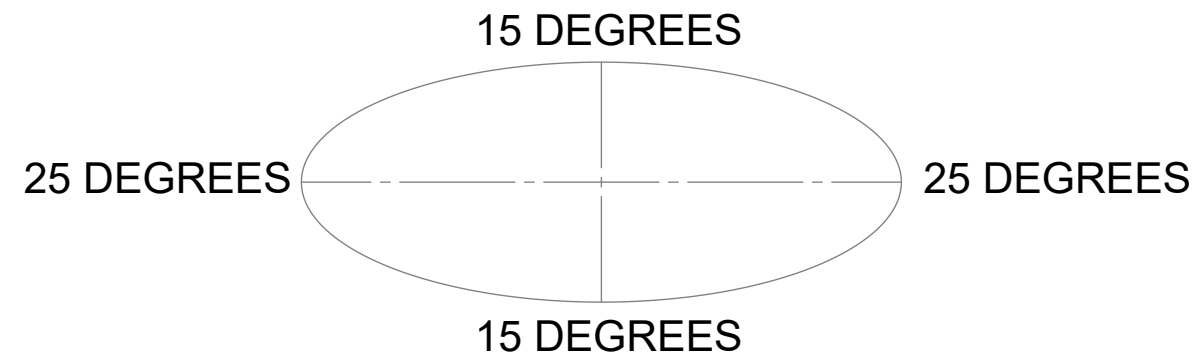

SFG21HD-10-4-96 SHOWN FOR REFERENCE
(NOT ALL CONFIGURATIONS INCLUDE ALL ITEMS SEE
NOTES IN TABLE ON PAGE 3)

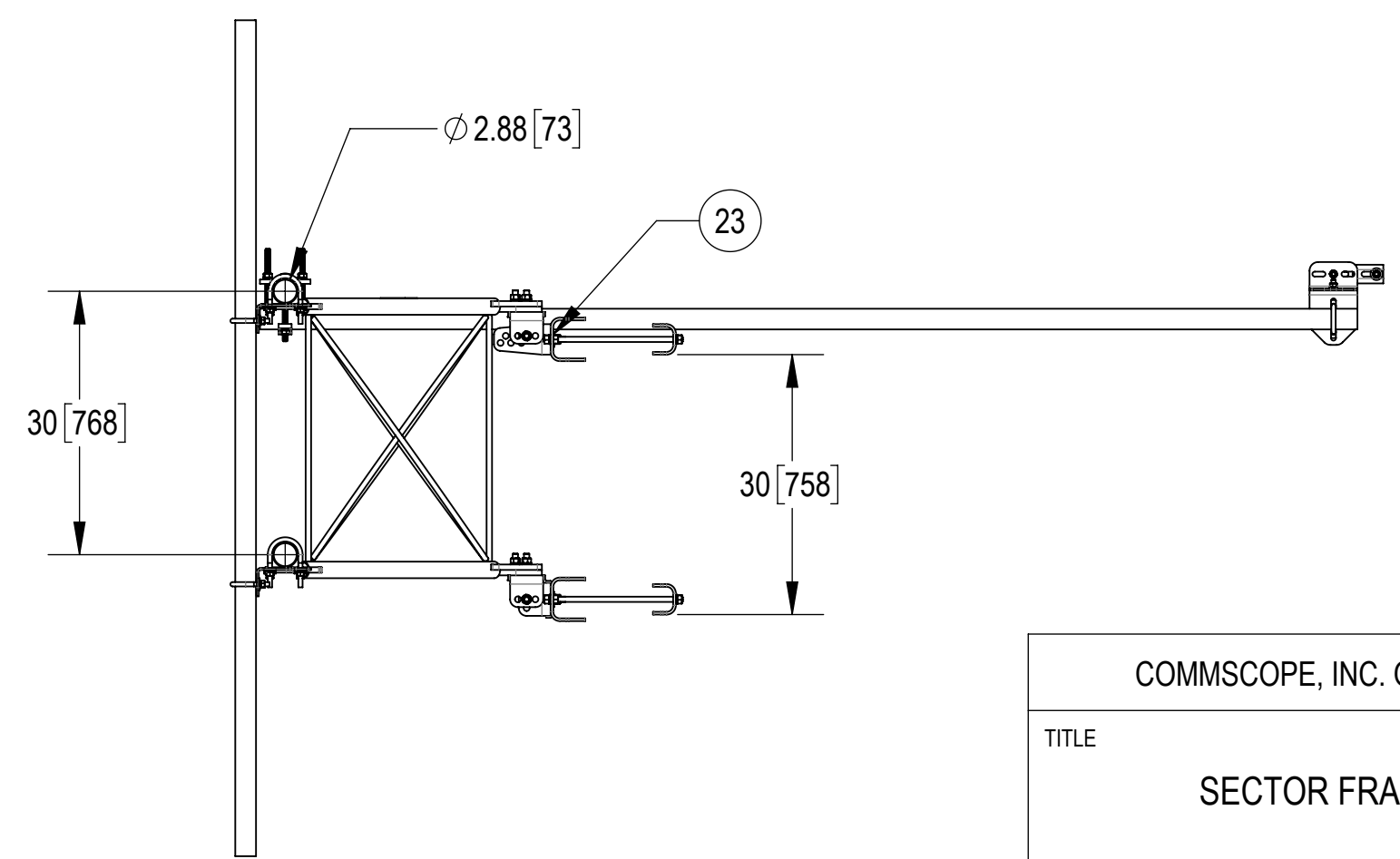
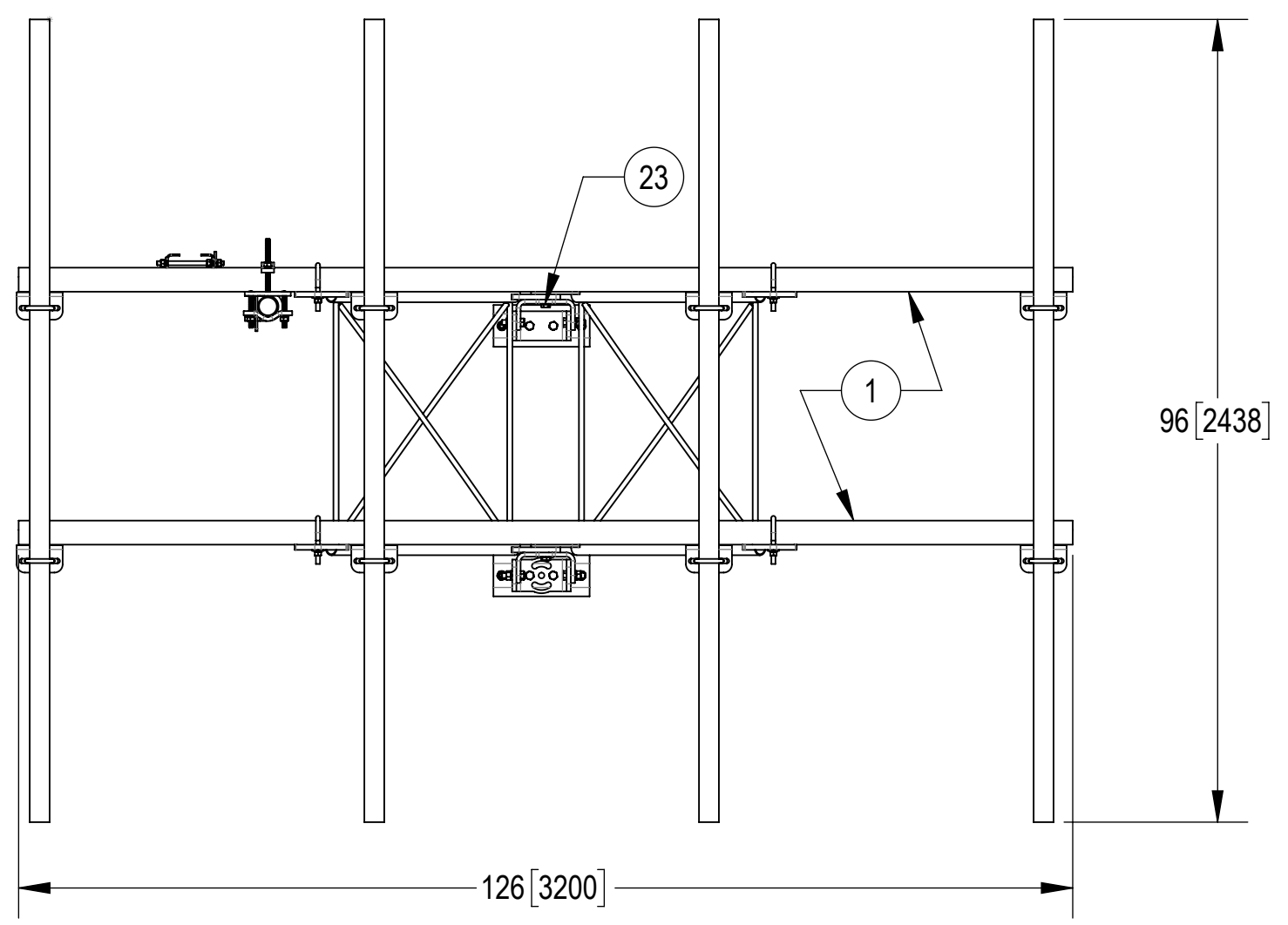

COMMSCOPE, INC. OF NORTH CAROLINA				
TITLE SECTOR FRAME - SFG21HD				
SIZE C	SCALE 1:20	DOCUMENT NO. SFG21HD		
DRAWING		VERSION	STATUS	REVISION
DRAWING		07	RE	G
SHEET 4 OF 8				

4

3

2

1

STEP1: ATTACH STANDOFF ARMS (SFV01) TO AZIMUTH BRACKETS (SFV02) USING BOLT KITS (GB-05305) AND FLAT WASHERS (GWF-05)
 PLACE LABEL (SFG2152) ON TOP OF STANDOFF ARMS (SFV01). (WIPE GALVANIZED SURFACE WITH ALCOHOL CLEANER BEFORE
 APPLYING LABEL)

LOWER ARM "UPSIDE DOWN" UPPER ARM "RIGHT SIDE UP"

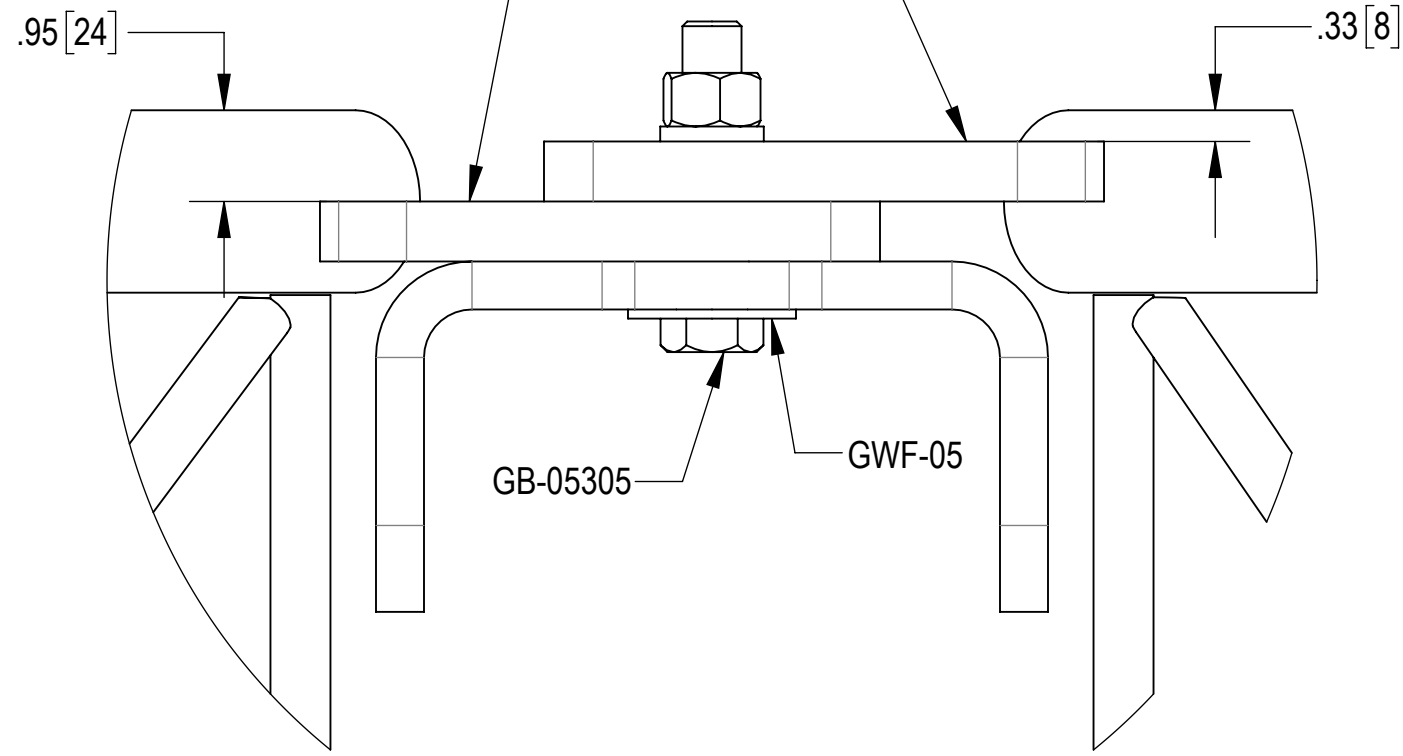

DETAIL C
 SCALE 1 : 2

STANDOFF ARM ORIENTATION IS CRITICAL!
 WHEN ASSEMBLED, ARMS SHOULD BE LEVEL
 WITH EACH OTHER. ALSO SEE DETAIL C ABOVE

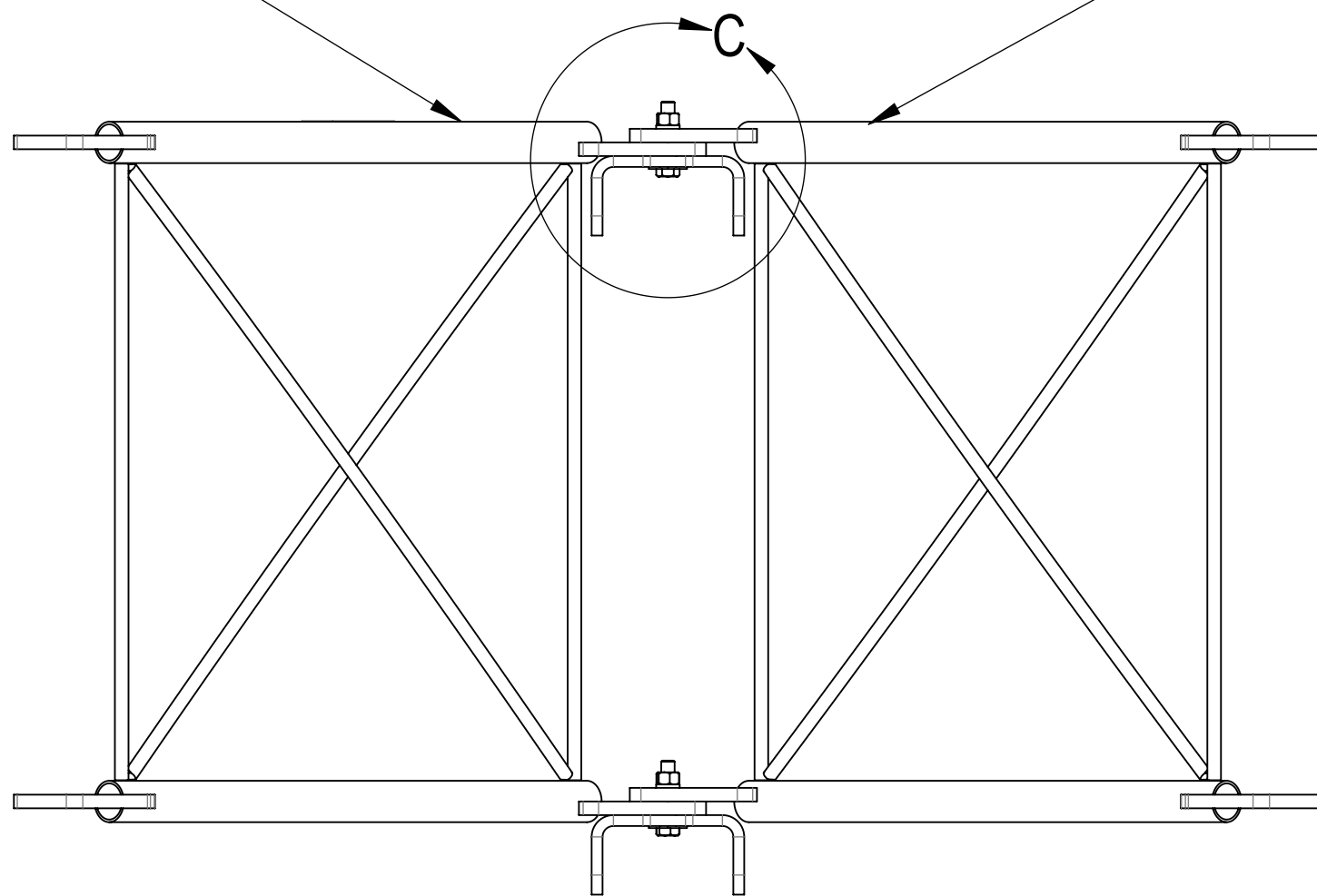

RECOMMENDED LOCATION
 (AVOID BEING COVERED)

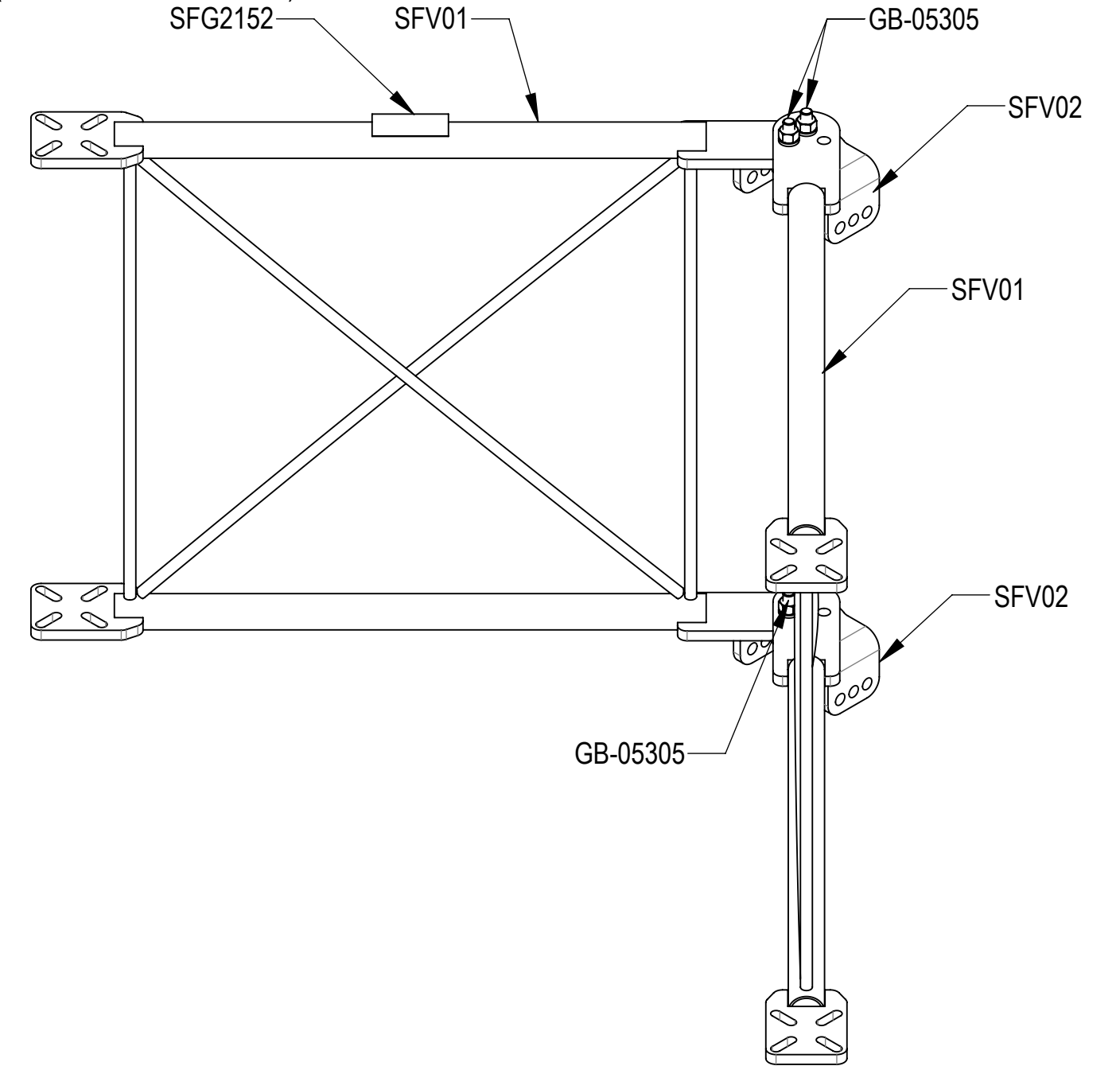

COMMSCOPE, INC. OF NORTH CAROLINA				
TITLE				
SECTOR FRAME - SFG21HD				
SIZE	SCALE	DOCUMENT NO.		
C	1:8	SFG21HD		
		DRAWING		
		VERSION	STATUS	REVISION
		07	RE	G
				SHEET
				5 OF 8

STEP 2A: ON TOP, ATTACH TAPER BRACKET (SFV03) TO AZIMUTH BRACKET (SFV02) USING BOLT KITS (GB-05225).
 SEE ISO ROTATED VIEW. ATTACH TAPER BRACKET (SFV03) TO CLAMP, FRONT MTG (MTC397522) USING BOLT KITS (GB-05225)
 AND FLAT WASHERS (GWF-05).

STEP 2B: ON BOTTOM, ATTACH AZIMUTH BRACKET (SFV02) TO AZIMUTH BRACKET (SFV02) USING BOLT KITS (GB-05225).
 ATTACH AZIMUTH BRACKET (SFV02) TO CLAMP, FRONT MTG (MTC397522) USING BOLT KITS(GB-05225)
 AND FLAT WASHERS (GWF-05).

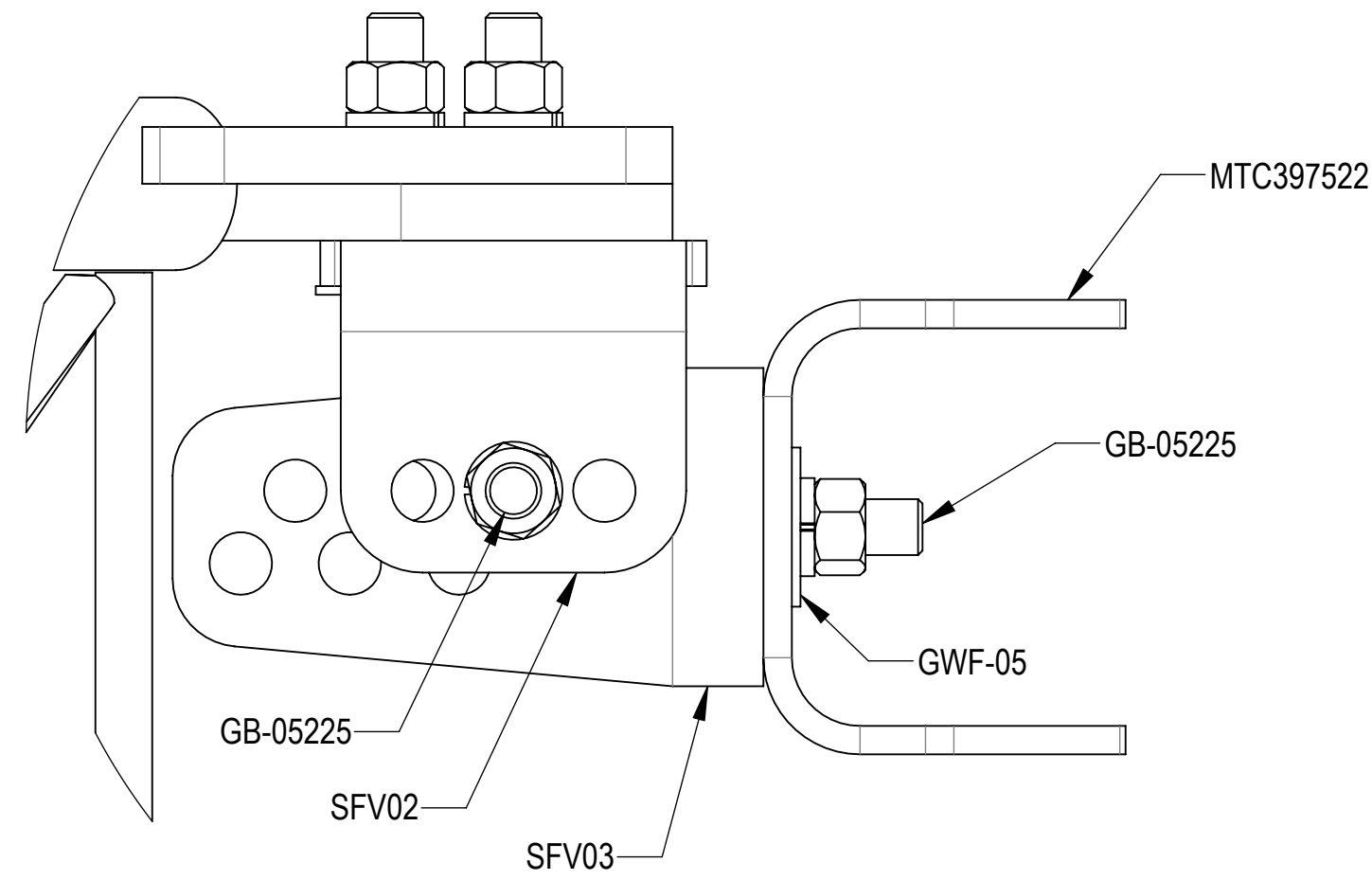

DETAIL D
 SCALE 1 : 2

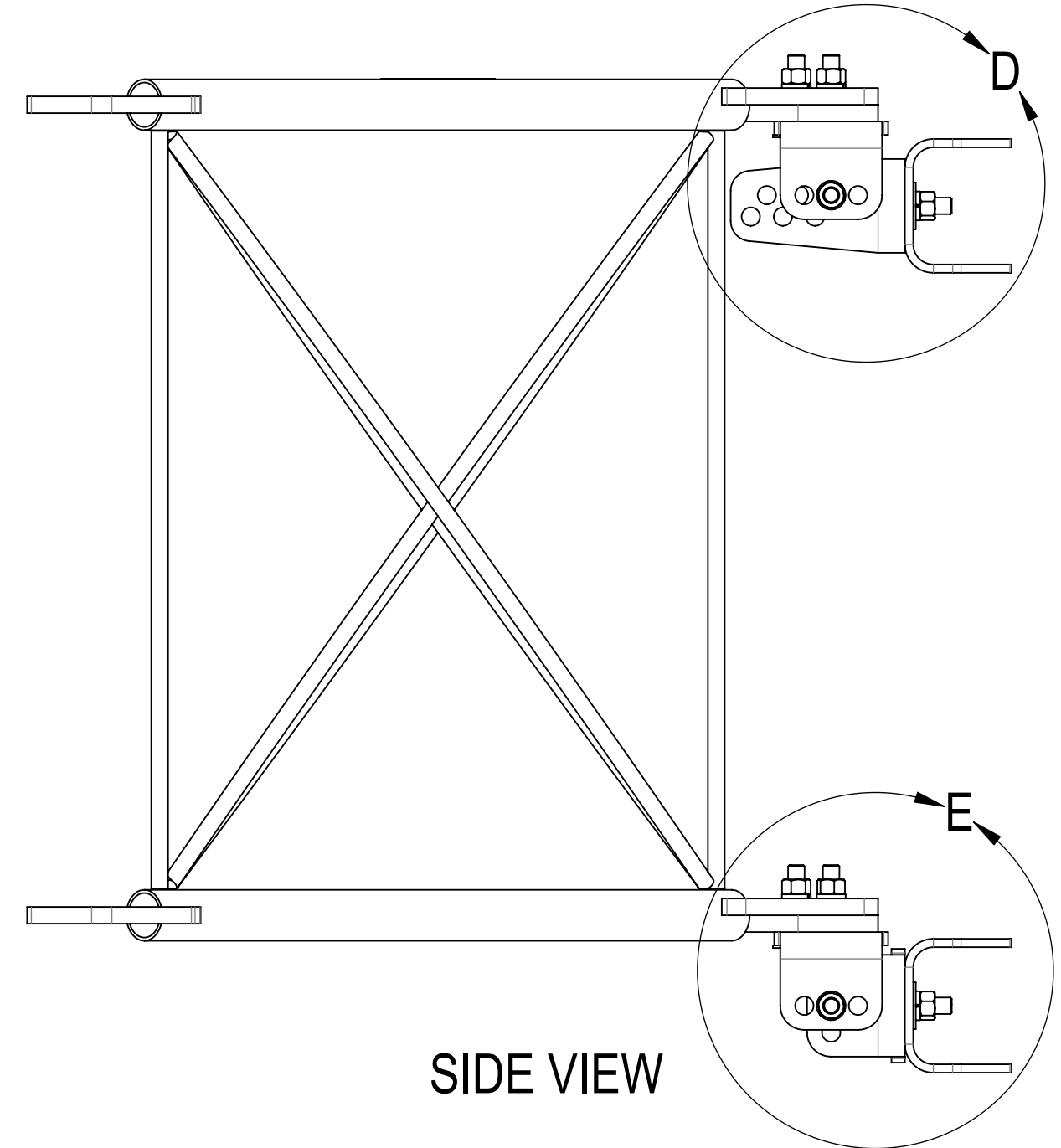

SIDE VIEW

STANDOFF ARM ORIENTATION
 IS CRITICAL! WHEN ASSEMBLED,
 PIPES SHOULD BE LEVEL

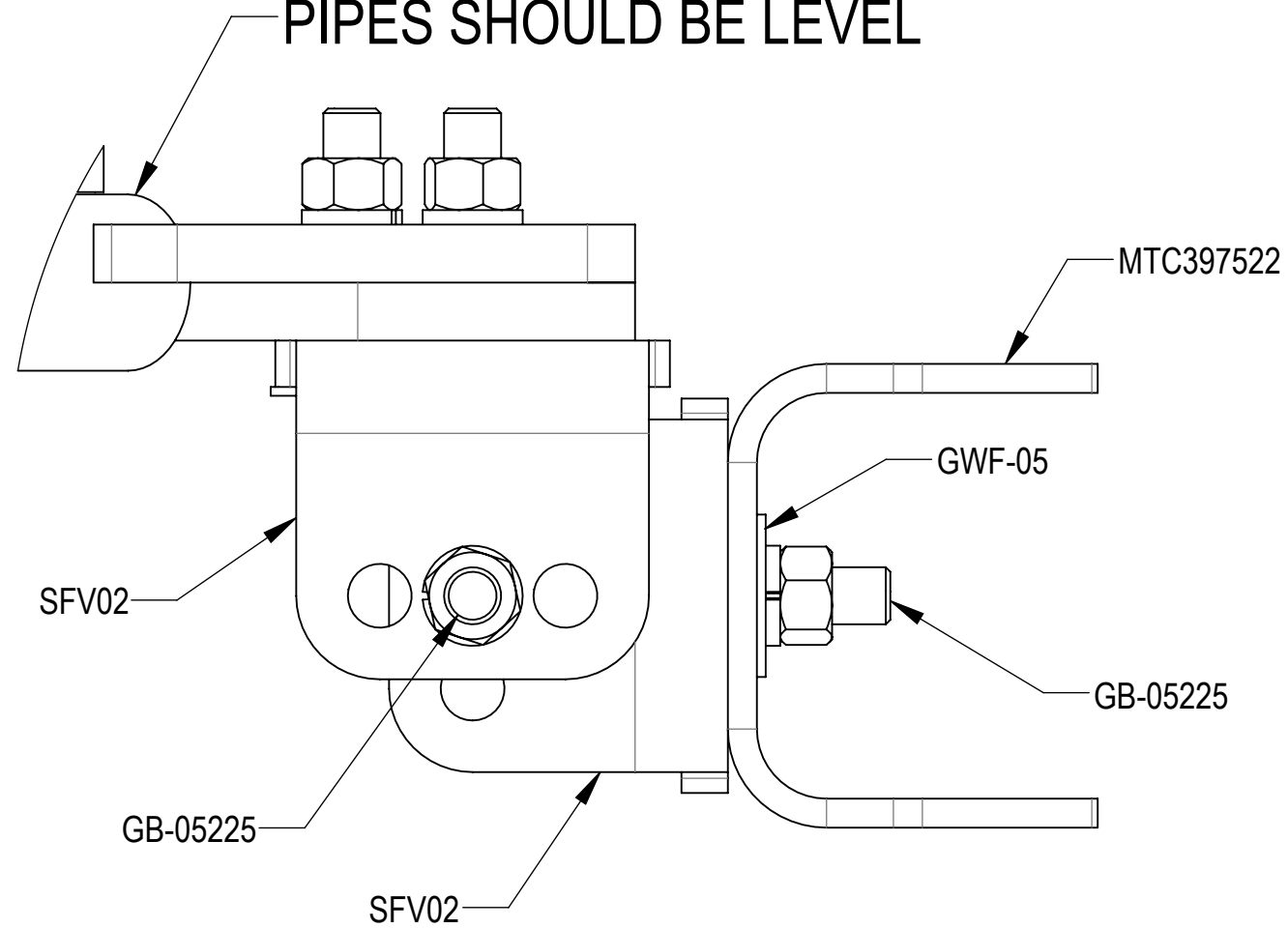

DETAIL E
 SCALE 1 : 2

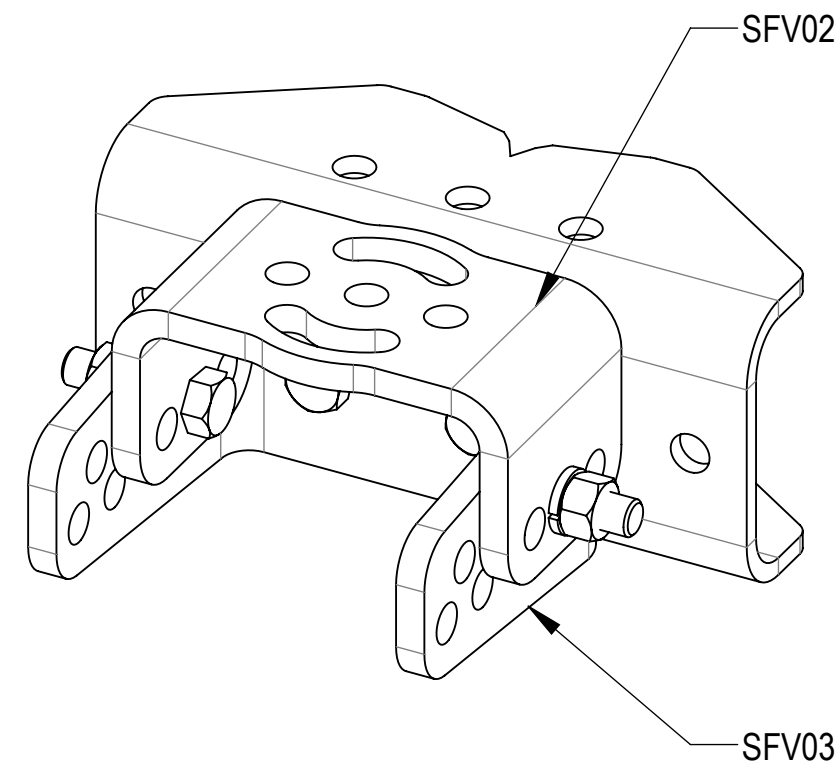

ISO ROTATED VIEW

COMMSCOPE, INC. OF NORTH CAROLINA				
TITLE				
SECTOR FRAME - SFG21HD				
SIZE	SCALE	DOCUMENT NO.		
C	1:4	SFG21HD		
		DRAWING		
		VERSION	STATUS	REVISION
		07	RE	G
				SHEET
				6 OF 8

STEP 3: ATTACH FACE PIPES TO STANDOFF ARMS (SFV01) USING U-BOLTS (GUB-4352).

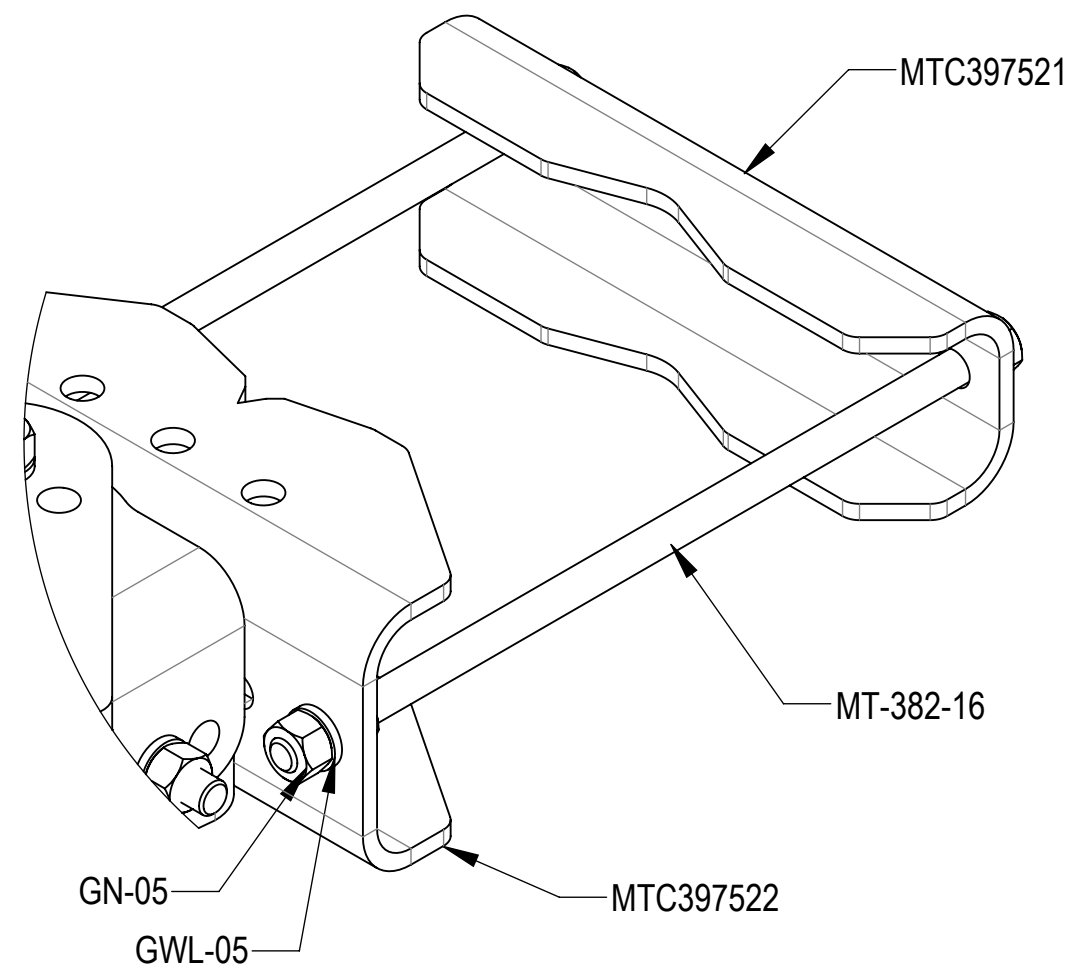

DETAIL G
SCALE 1 : 3

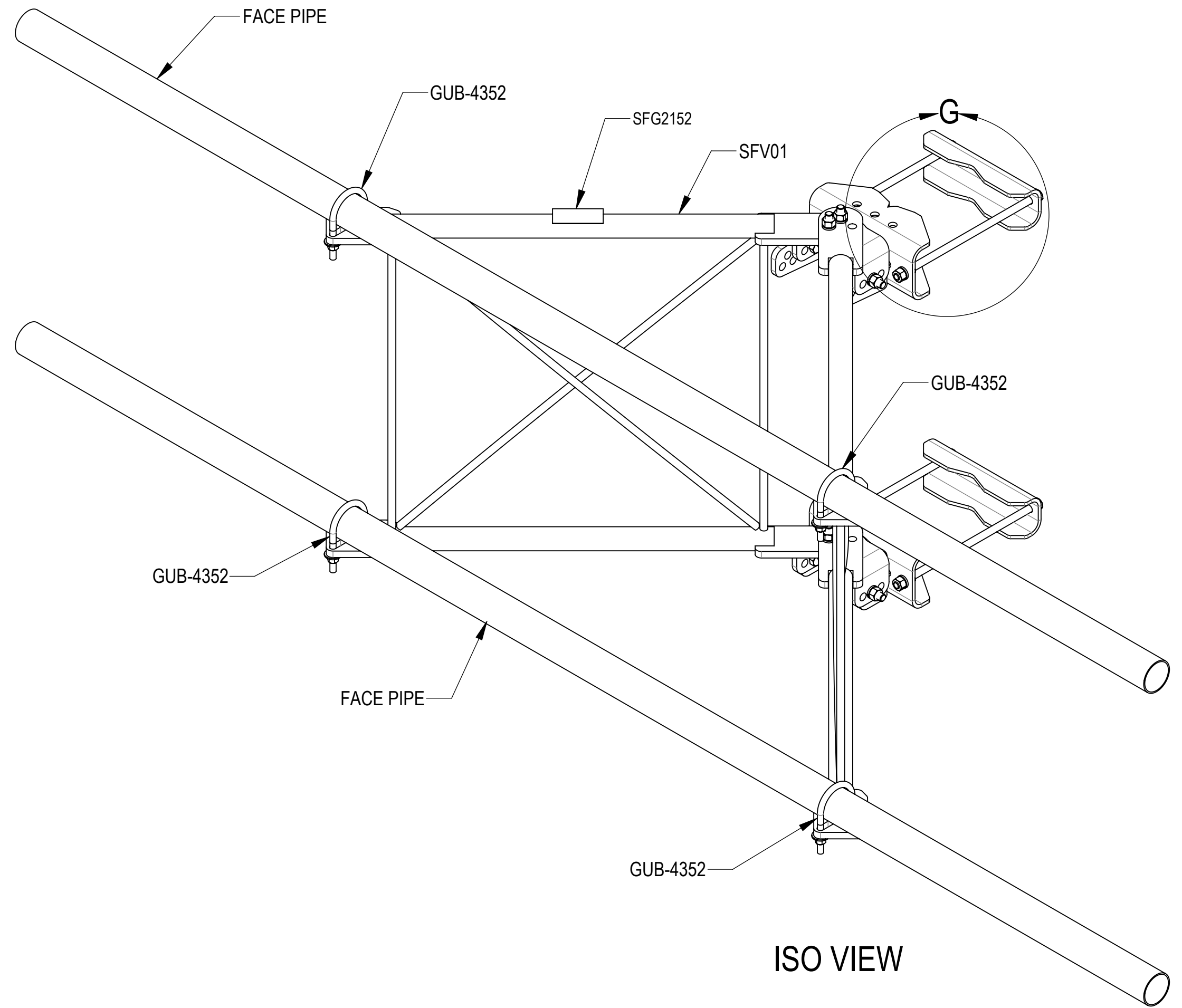

ISO VIEW

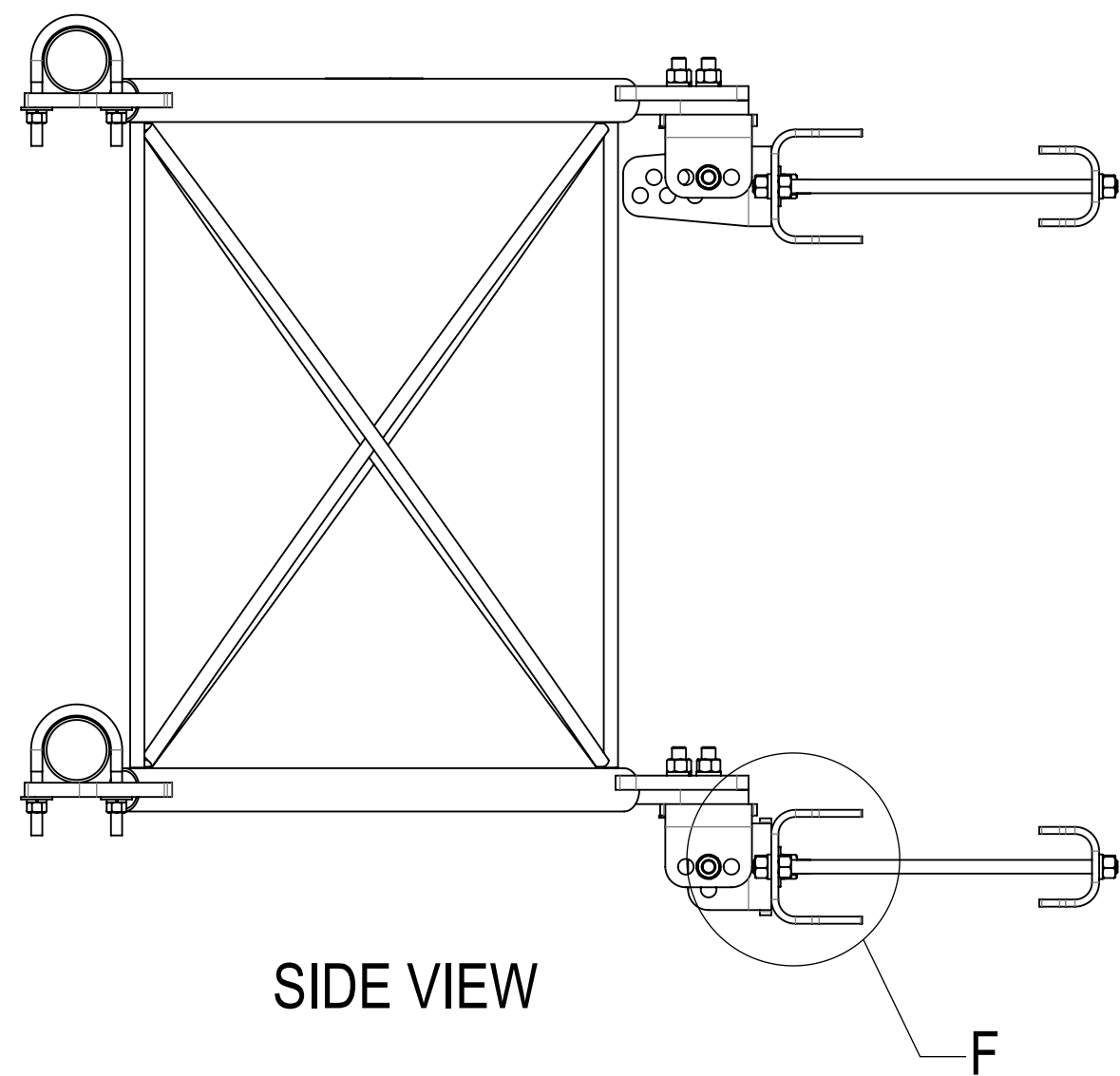

SIDE VIEW

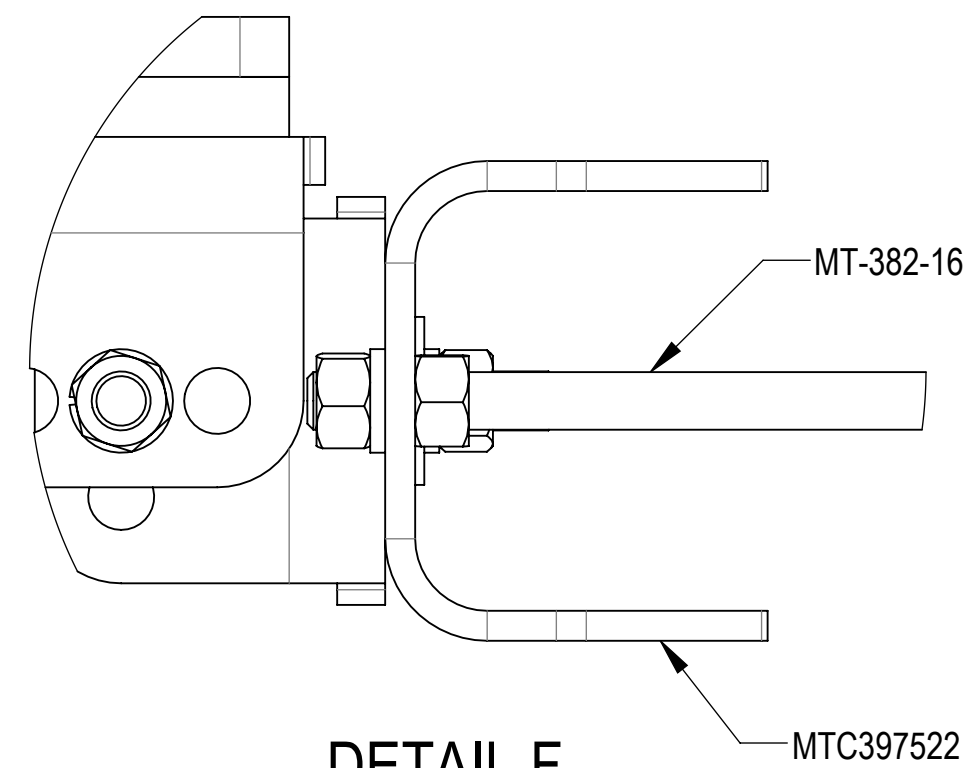

DETAIL F
SCALE 1 : 2

COMMSCOPE, INC. OF NORTH CAROLINA				
TITLE SECTOR FRAME - SFG21HD				
SIZE C	SCALE 1:8	DOCUMENT NO. SFG21HD		
		DRAWING		SHEET 7 OF 8
		VERSION 07	STATUS RE	

STEP 4: ATTACH ANTENNA PIPES TO FACE PIPES USING CROSSOVER PLATES (XAU01) AND U-BOLTS (GUB-4352 & GUB-4240). ATTACH TIE BACK PIPE (MT-537) TO FACE PIPE USING CROSSOVER PLATE KITS (XP-R).

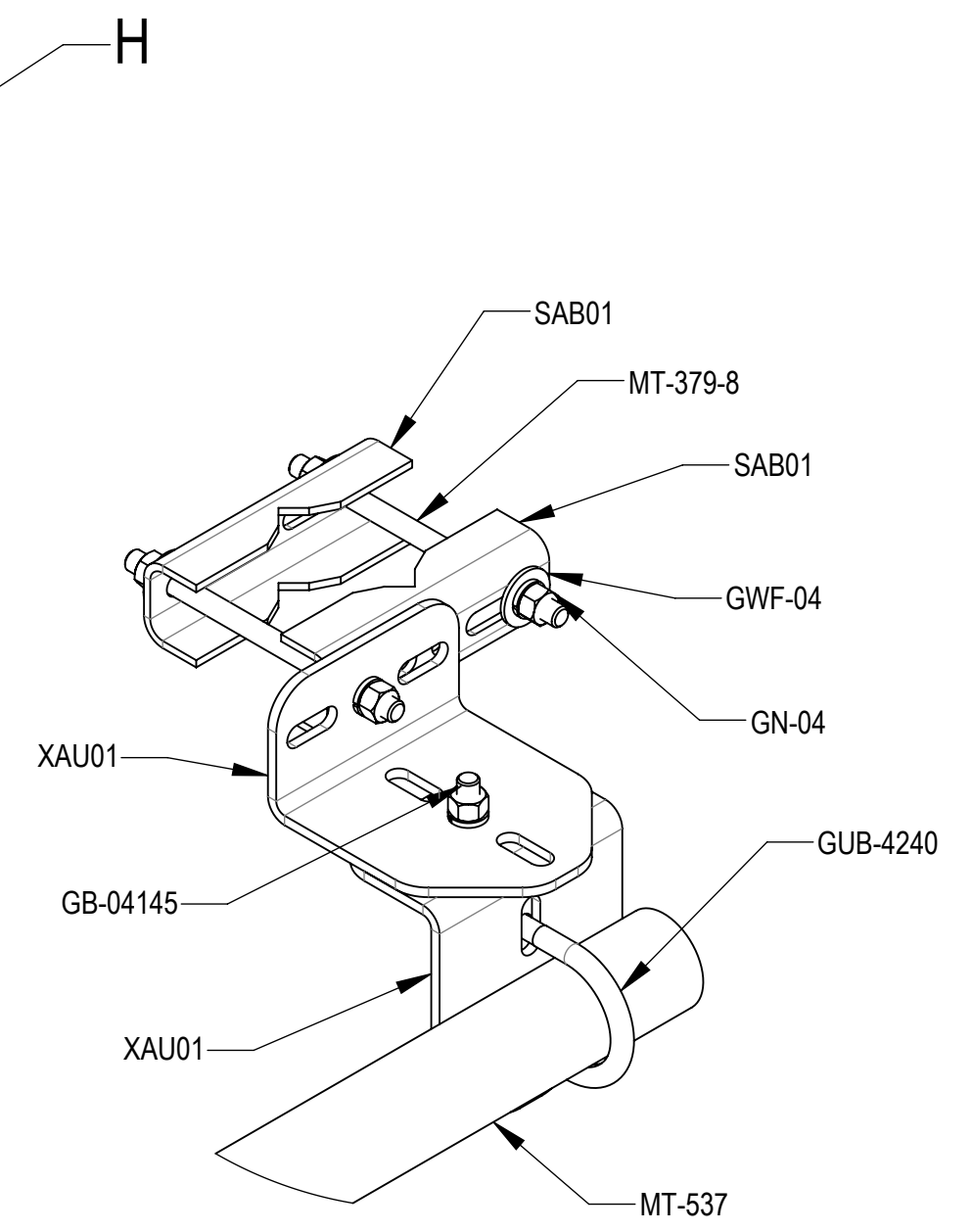
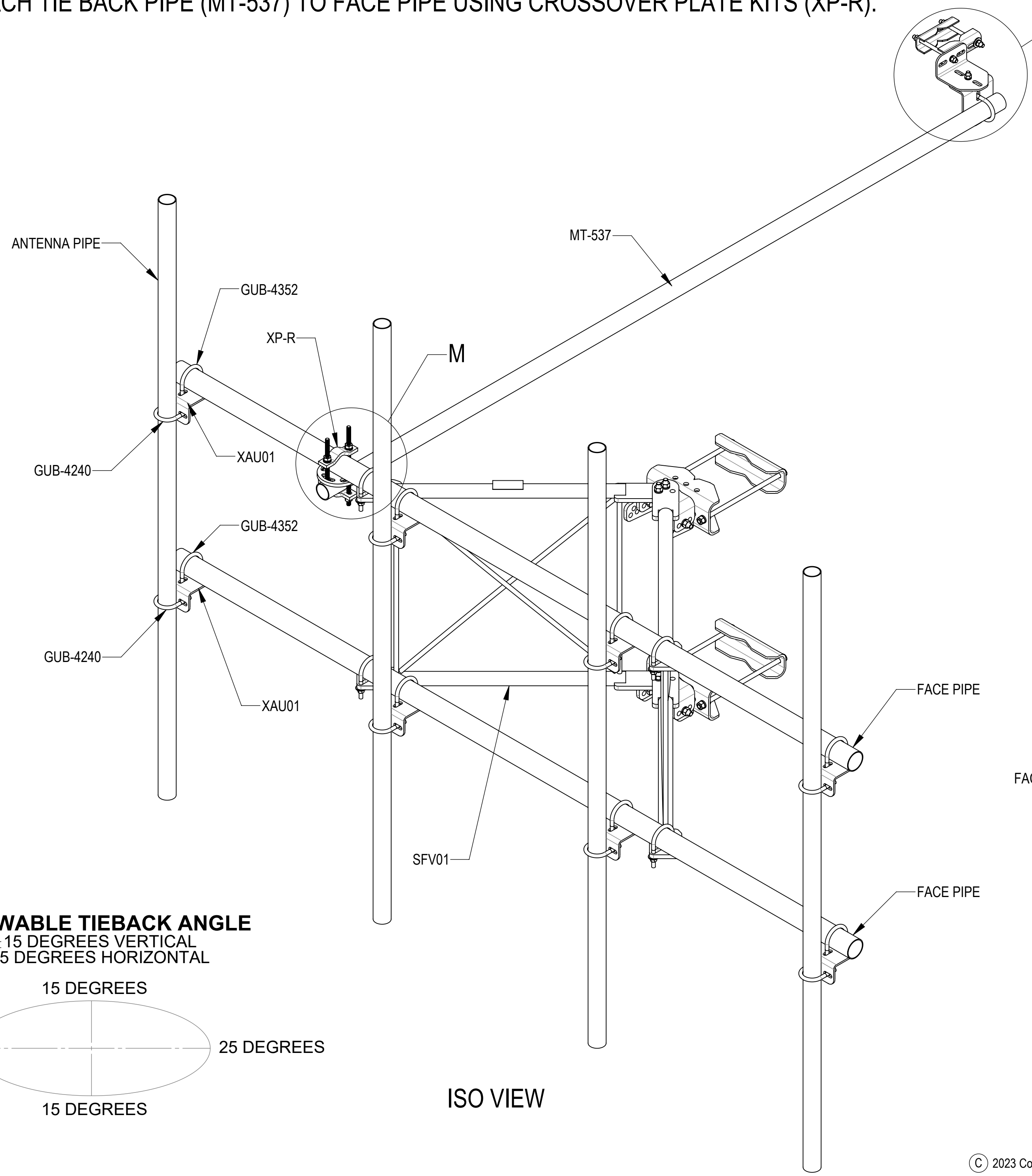

DETAIL H
SCALE 1 : 4

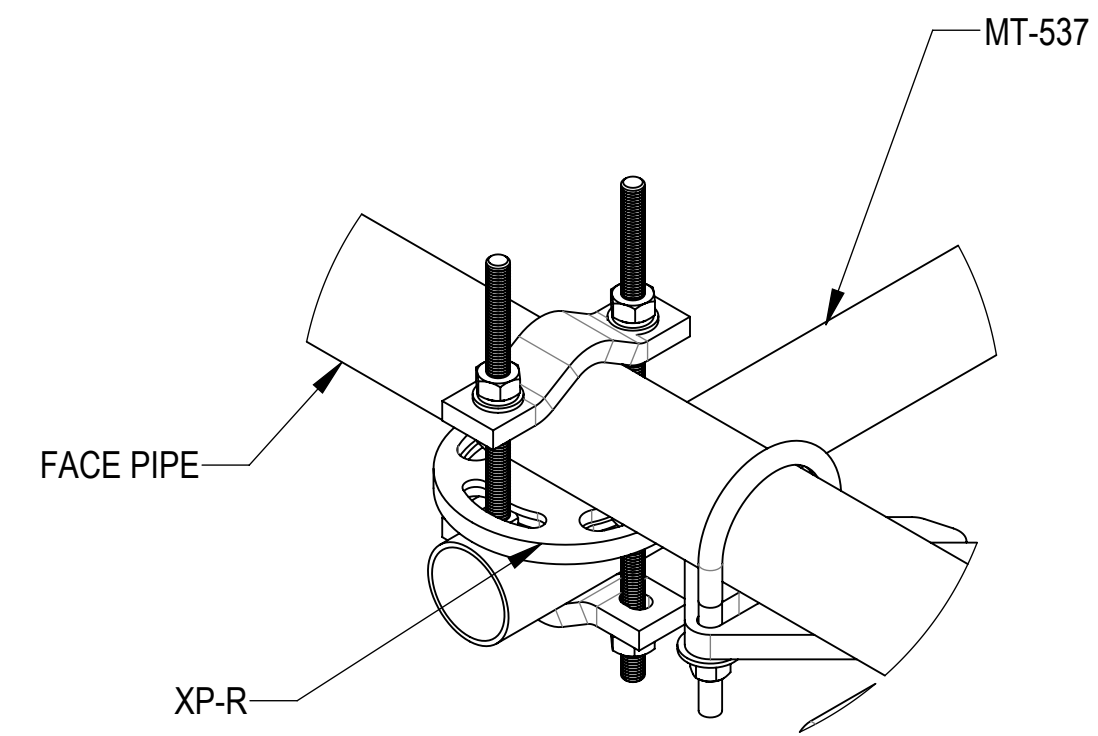

DETAIL M
SCALE 1 : 4

ALLOWABLE TIEBACK ANGLE
 ±15 DEGREES VERTICAL
 ±25 DEGREES HORIZONTAL

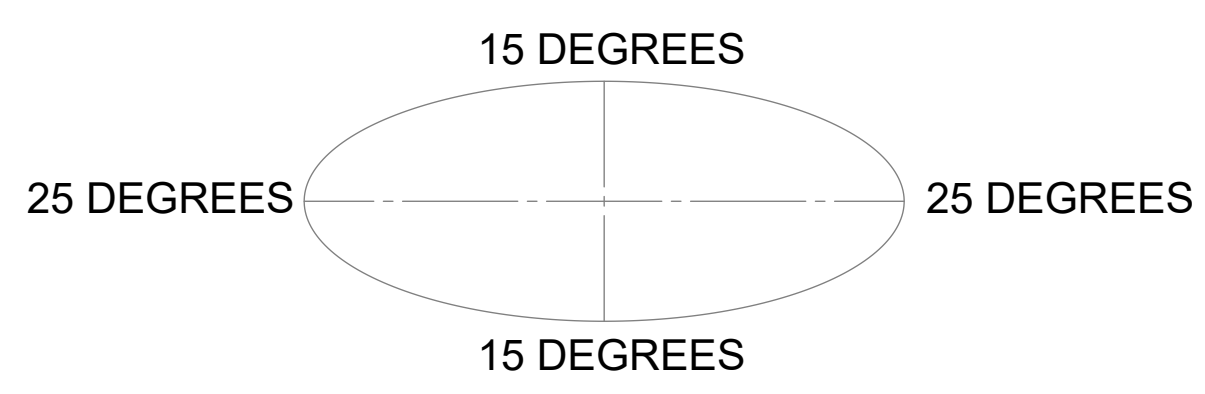

ISO VIEW

COMMSCOPE, INC. OF NORTH CAROLINA					
TITLE SECTOR FRAME - SFG21HD					
SIZE C	SCALE 1:10	DOCUMENT NO. SFG21HD			
		DRAWING			SHEET 8 OF 8
		VERSION 07	STATUS RE	REVISION G	