

REVISIONS				
REV.	ZONE	DESCRIPTION	BY	DATE
A		INITIAL RELEASE	WLJ	09/04/99
C		UPDATE PART NUMBER FROM ZB-V12.01	MLL	04/18/00
D		UPDATE BORDER AND DIMENSIONS	GB	05/13/01
E		REDESIGN	MSM	06/23/08

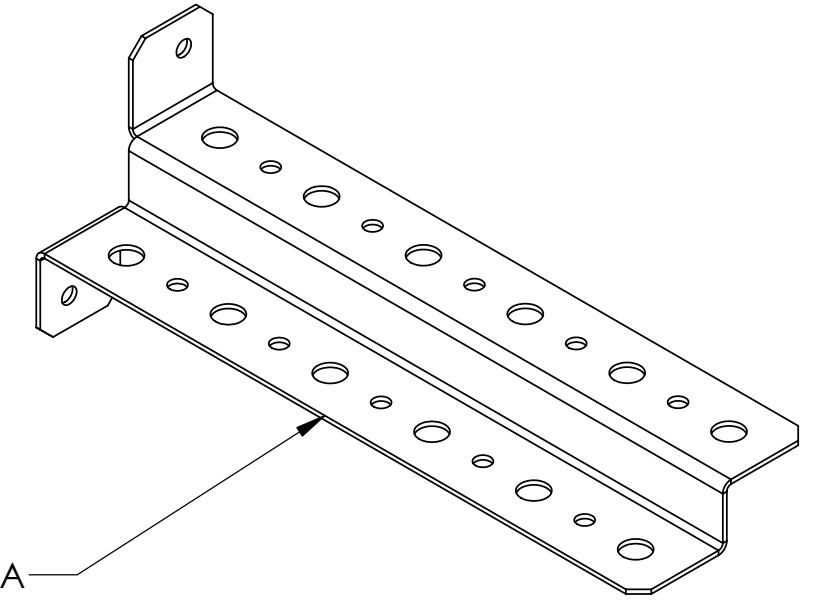

MAT'L: SMG 11 GA

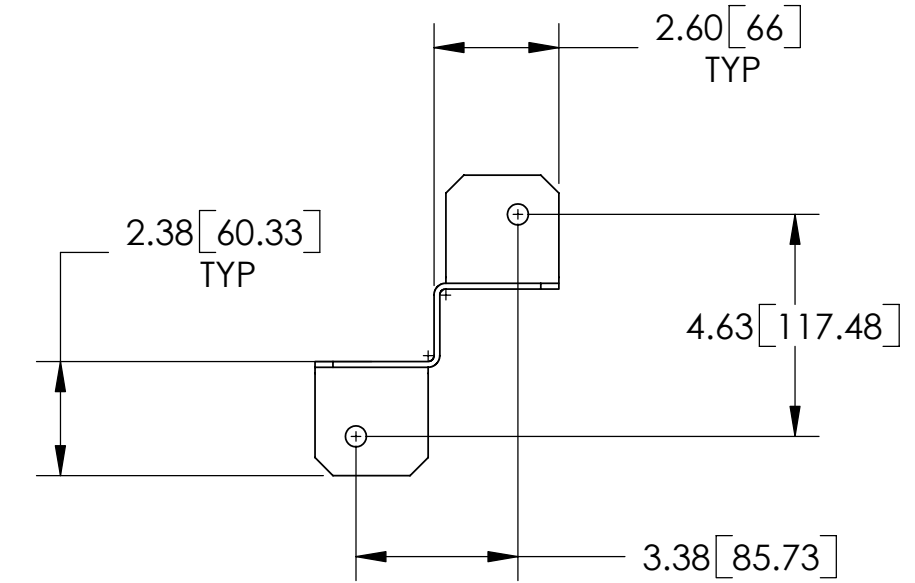
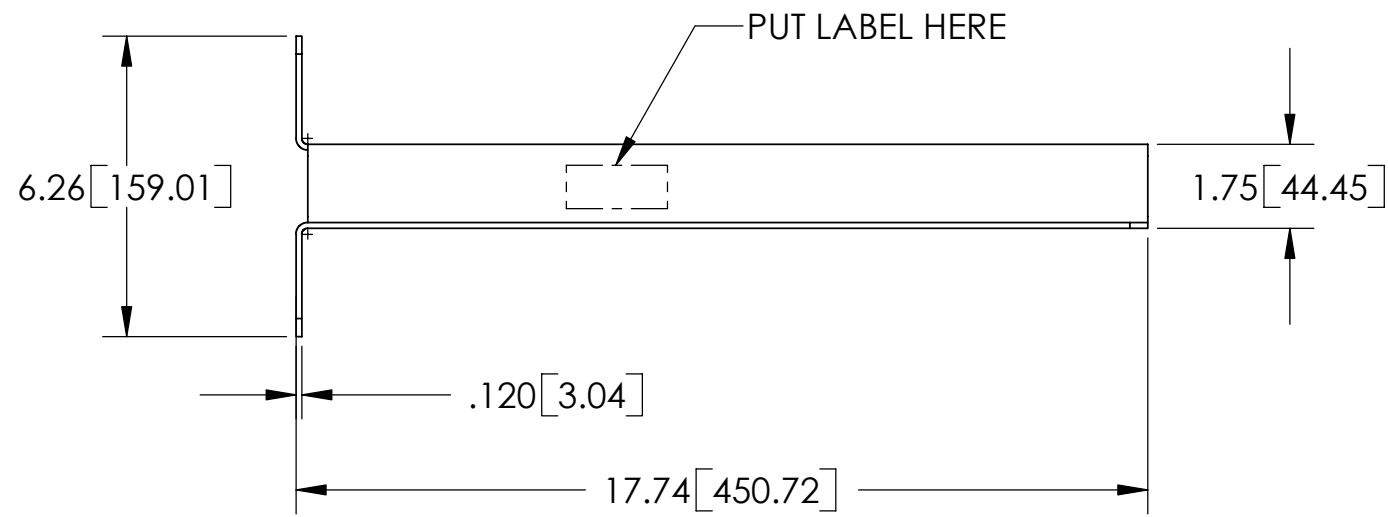
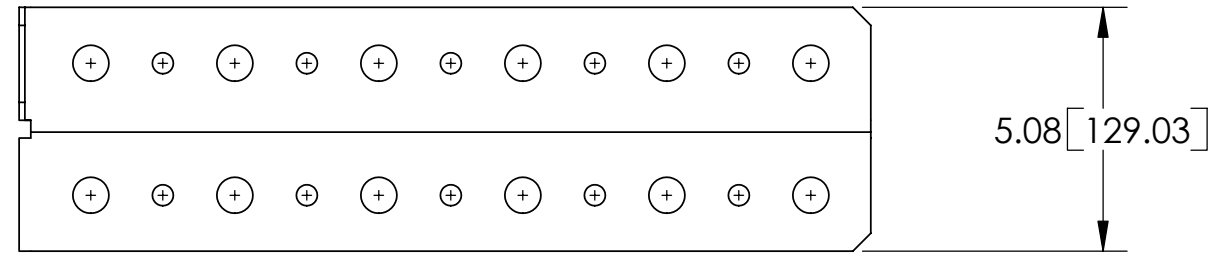

NOTES:
 1. ALL METRIC DIMENSIONS ARE IN BRACKETS.
 2. STAMP PART IDENTIFICATION NUMBER.

These drawings and specifications are the proprietary property of ANDREW CORPORATION and may be used only for the specific purpose authorized in writing by Andrew Corporation. ALL DIMENSIONS ARE IN INCHES U.O.S. TOLERANCES UNLESS OTHERWISE SPECIFIED: .X = ± .12 ANGLES ±2° .XX = ± .06 FRACTIONS ±1/32 .XXX = ± .030 REMOVE BURRS AND BREAK EDGES .005 DO NOT SCALE THIS PRINT	DRAWN BY: ACG	SHEET: 1 of 1	PART NUMBER: ZB-V12
	CHECKED BY: TP	SCALE: NTS	DESCRIPTION: VERTICAL Z-BRACKET
	DATE: 04/21/06	MATERIAL: A568	DRAWING TYPE: SHOP DRAWING
	REVISION: E	FINISH: NONE	WEIGHT: 4.00 LBS

 ORLAND PARK, IL. 60462 U.S.A.