

400BPDM-C



7-16 DIN Male for CNT-400 braided cable

Product Classification

Product Type	Braided cable connector
Product Brand	CNT®

General Specifications

Body Style	Straight
Inner Contact Attachment Method	Captivated
Inner Contact Plating	Silver
Interface	7-16 DIN Male
Outer Contact Attachment Method	Clamp
Outer Contact Plating	Trimetal

Dimensions

Width	35 mm 1.378 in
Length	40.73 mm 1.604 in
Diameter	35 mm 1.378 in
Nominal Size	0.405 in

Outline Drawing

400BPDM-C

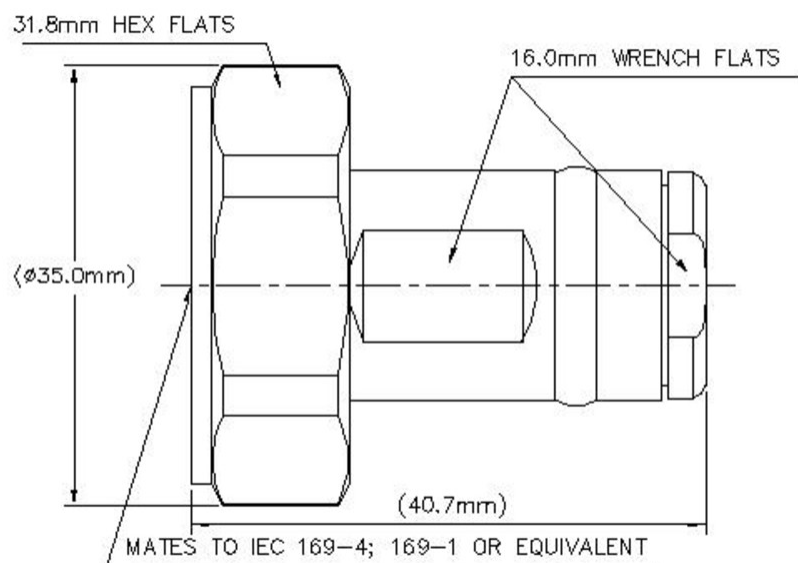

Electrical Specifications

Insertion Loss, typical	0.05 dB
Average Power at Frequency	580.0 W @ 900 MHz
Cable Impedance	50 ohm
Connector Impedance	50 ohm
dc Test Voltage	2500 V
Inner Contact Resistance, maximum	1.5 mOhm
Insulation Resistance, minimum	10000 MOhm
Operating Frequency Band	0 – 6000 MHz
Outer Contact Resistance, maximum	0.4 mOhm
RF Operating Voltage, maximum (vrms)	894 V

VSWR/Return Loss

Frequency Band	VSWR	Return Loss (dB)
0–3000 MHz	1.05	32.26
3000–6000 MHz	1.119	25.01

Mechanical Specifications

Connector Retention Tensile Force	330 N 74.187 lbf
Connector Retention Torque	0.56 N-m 4.956 in lb

400BPDM-C

Coupling Nut Proof Torque	35 N-m 309.776 in lb
Coupling Nut Proof Torque Method	IEC 61169-4:9.3.6
Coupling Nut Retention Force	1000 N 224.809 lbf
Coupling Nut Retention Force Method	IEC 61169-4:15.2.6
Interface Durability	500 cycles
Interface Durability Method	IEC 61169-4:17
Mechanical Shock Test Method	IEC 60068-2-27

Environmental Specifications

Operating Temperature	-40 °C to +85 °C (-40 °F to +185 °F)
Storage Temperature	-65 °C to +125 °C (-85 °F to +257 °F)
Attenuation, Ambient Temperature	20 °C 68 °F
Average Power, Ambient Temperature	40 °C 104 °F
Average Power, Inner Conductor Temperature	100 °C 212 °F
Climatic Sequence Test Method	IEC 60068-1
Corrosion Test Method	IEC 60068-2-11
Damp Heat Steady State Test Method	IEC 60068-2-3
Immersion Depth	1 m
Immersion Test Mating	Mated
Immersion Test Method	IEC 60529:2001, IP68
Thermal Shock Test Method	IEC 60068-2-14
Vibration Test Method	IEC 60068-2-6

Packaging and Weights

Weight, net	44.58 g 0.098 lb
--------------------	--------------------

Regulatory Compliance/Certifications

Agency	Classification
CHINA-ROHS	Below maximum concentration value
ISO 9001:2015	Designed, manufactured and/or distributed under this quality management system
REACH-SVHC	Compliant as per SVHC revision on www.commscope.com/ProductCompliance
ROHS	Compliant
UK-ROHS	Compliant

400BPDM-C



* Footnotes

Insertion Loss, typical 0.05√freq (GHz) (not applicable for elliptical waveguide)

Immersion Depth Immersion at specified depth for 24 hours