

E14F10P17

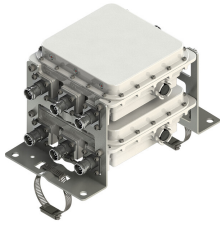

2X Triplexer 1710-1880/1920-2170/2300-2690, DC Smart Bypass, 4.3-10 connectors

- Industry leading PIM performance
- Twin configuration
- Designed for network Modernization, introduction of LTE1800 on existing site
- Designed for network Modernization, introduction of LTE2600 on existing site
- New 4.3-10 connectors for improved PIM performance and size reduction

Product Classification

Product Type Triplexer

General Specifications

Product Family CBC182126

Color Gray

Common Port Label COMM

Modularity 2-Twin

Mounting Pole | Wall

Mounting Pipe Hardware Band clamps (2)

RF Connector Interface 4.3-10 Female

RF Connector Interface Body Style Medium neck

Dimensions

Height 182.5 mm | 7.185 in

Width 156 mm | 6.142 in

Depth 173.5 mm | 6.831 in

Mounting Pipe Diameter Range 42.6–122 mm

E14F10P17

Outline Drawing

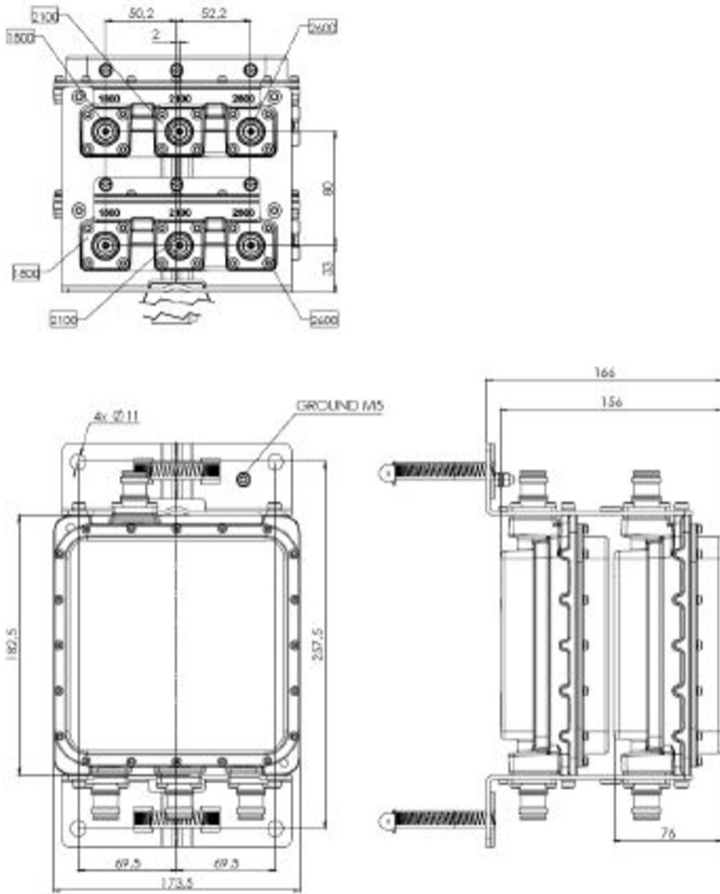

Electrical Specifications

Impedance	50 ohm
License Band, Band Pass	DCS 1800 IMT 2100 IMT 2600

Electrical Specifications, dc Power/Alarm

dc/AISG Pass-through, combiner	Autosensing
dc/AISG Pass-through, demultiplexer	Autosensing
Lightning Surge Current	5 kA
Lightning Surge Current Waveform	8/20 waveform

E14F10P17

Electrical Specifications

Sub-module	1 2	1 2	1 2
Branch	1	2	3
Port Designation	1800	2100	2600
License Band	DCS 1800, Band Pass	IMT 2100, Band Pass	IMT 2600, Band Pass

Electrical Specifications, Band Pass

Frequency Range, MHz	1710–1880	1920–2170	2300–2690
Insertion Loss, typical, dB	0.25	0.25	0.2
Return Loss, minimum, dB	18	18	18
Return Loss, typical, dB	20	20	20
Isolation, minimum, dB	50	50	50
Input Power, RMS, maximum, W	300	300	300
3rd Order PIM, typical, dBc	-160	-160	-160
3rd Order PIM Test Method	Two +43 dBm carriers	Two +43 dBm carriers	Two +43 dBm carriers

Block Diagram

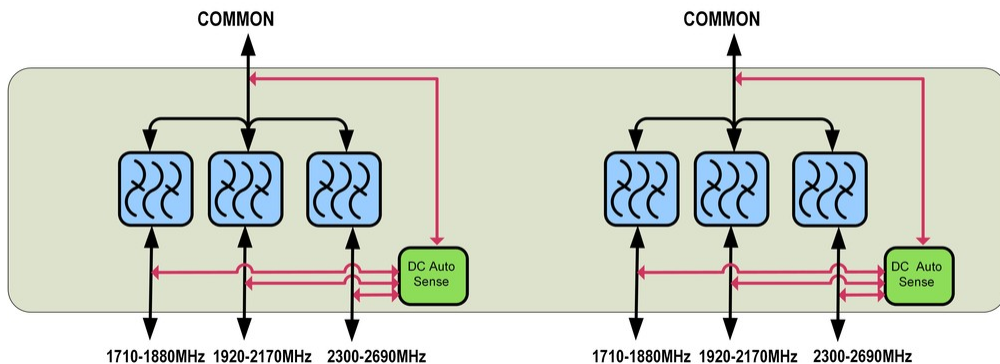

Environmental Specifications

Operating Temperature	-40 °C to +60 °C (-40 °F to +140 °F)
Relative Humidity	Up to 100%
Corrosion Test Method	IEC 60068-2-11, 30 days
Ingress Protection Test Method	IEC 60529:2001, IP67

Packaging and Weights

Included	Mounting hardware
-----------------	-------------------

E14F10P17

Volume 5 L
Weight, net 6 kg | 13.228 lb

Regulatory Compliance/Certifications

Agency

ISO 9001:2015

Classification

Designed, manufactured and/or distributed under this quality management system

