

# AL5E78-PS

---

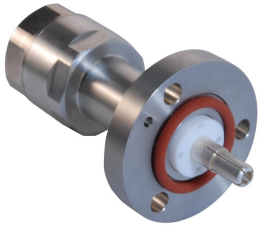

7/8 in EIA Positive Stop™ for 7/8 in AVA5-50 and AL5-50 cable

## Product Classification

<b>Product Type</b>	Wireless and radiating connector
<b>Product Brand</b>	HELIAX®   Positive Stop™
<b>Product Series</b>	AVA5-50   AVA5RK-50

## General Specifications

<b>Body Style</b>	Straight
<b>Cable Family</b>	AL5-50   AVA5-50
<b>Inner Contact Attachment Method</b>	Captivated
<b>Inner Contact Plating</b>	Silver
<b>Interface</b>	7/8 in EIA Flange
<b>Mounting Angle</b>	Straight
<b>Outer Contact Attachment Method</b>	Ring-flare
<b>Outer Contact Plating</b>	Trimetal
<b>Pressurizable</b>	No

## Dimensions

<b>Length</b>	88.65 mm   3.49 in
<b>Diameter</b>	57.15 mm   2.25 in
<b>Nominal Size</b>	7/8 in

## Outline Drawing

# AL5E78-PS

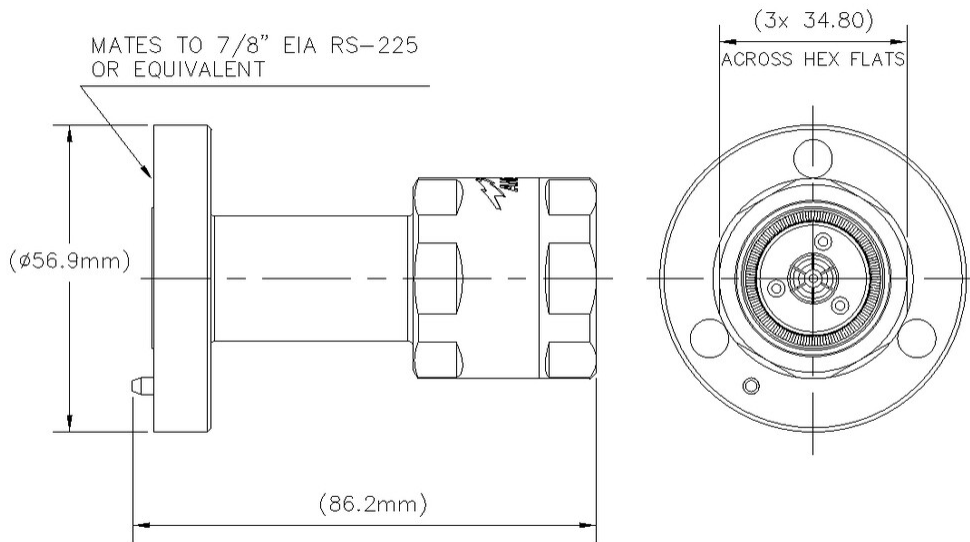

## Electrical Specifications

<b>3rd Order IMD at Frequency</b>	-116 dBm @ 910 MHz
<b>3rd Order IMD Test Method</b>	Two +43 dBm carriers
<b>Insertion Loss Coefficient, typical</b>	0.05
<b>Average Power at Frequency</b>	2.3 kW @ 900 MHz
<b>Cable Impedance</b>	50 ohm
<b>Connector Impedance</b>	50 ohm
<b>dc Test Voltage</b>	6000 V
<b>Inner Contact Resistance, maximum</b>	1.5 mOhm
<b>Insulation Resistance, minimum</b>	5000 MOhm
<b>Operating Frequency Band</b>	0 – 5000 MHz
<b>Outer Contact Resistance, maximum</b>	1.5 mOhm
<b>Peak Power, maximum</b>	90 kW
<b>RF Operating Voltage, maximum (vrms)</b>	2120 V
<b>Shielding Effectiveness</b>	-130 dB

## VSWR/Return Loss

Frequency Band	VSWR	Return Loss (dB)
50–1000 MHz	1.036	35.05

# AL5E78-PS

---

<b>1700–2200 MHz</b>	1.036	35.05
<b>2400–2700 MHz</b>	1.065	30.04
<b>3400–3600 MHz</b>	1.119	25.01

## Mechanical Specifications

<b>Attachment Durability</b>	25 cycles
<b>Connector Retention Tensile Force</b>	1,334.47 N   300 lbf
<b>Connector Retention Torque</b>	8.1 N-m   71.691 in lb
<b>Coupling Nut Proof Torque</b>	24.86 N-m   220.003 in lb
<b>Insertion Force</b>	66.72 N   15 lbf
<b>Insertion Force Method</b>	IEC 61169-1:15.2.4
<b>Interface Durability</b>	50 cycles
<b>Mechanical Shock Test Method</b>	MIL-STD-202, Method 213, Test Condition I

## Environmental Specifications

<b>Operating Temperature</b>	-55 °C to +85 °C (-67 °F to +185 °F)
<b>Storage Temperature</b>	-55 °C to +85 °C (-67 °F to +185 °F)
<b>Attenuation, Ambient Temperature</b>	20 °C   68 °F
<b>Average Power, Ambient Temperature</b>	40 °C   104 °F
<b>Corrosion Test Method</b>	MIL-STD-1344A, Method 1001.1, Test Condition A
<b>Immersion Depth</b>	1 m
<b>Immersion Test Mating</b>	Unmated
<b>Immersion Test Method</b>	IEC 60529:2001, IP68
<b>Moisture Resistance Test Method</b>	MIL-STD-202F, Method 106F
<b>Thermal Shock Test Method</b>	MIL-STD-202F, Method 107G, Test Condition A-1, Low Temperature -55 °C
<b>Vibration Test Method</b>	MIL-STD-202F, Method 204D, Test Condition B
<b>Water Jetting Test Mating</b>	Unmated
<b>Water Jetting Test Method</b>	IEC 60529:2001, IP66

## Packaging and Weights

<b>Weight, net</b>	340.21 g   0.75 lb
--------------------	--------------------

## Regulatory Compliance/Certifications

<b>Agency</b>	<b>Classification</b>
---------------	-----------------------

# AL5E78-PS

---

CHINA-ROHS	Above maximum concentration value
ISO 9001:2015	Designed, manufactured and/or distributed under this quality management system
ROHS	Compliant/Exempted
UK-ROHS	Compliant/Exempted



### \* Footnotes

**Insertion Loss Coefficient, typical** 0.05√freq (GHz) (not applicable for elliptical waveguide)

**Immersion Depth** Immersion at specified depth for 24 hours