

L2PDM-C



7-16 DIN Male for 3/8 in LDF2-50 cable

OBSOLETE

This product was discontinued on: June 3, 2009

Replaced By:

L2TDM-PL	7-16 DIN Male Positive Lock for 3/8 in LDF2-50 cable
L2TKM-PL	4.1/9.5 Mini-Din Male connector with LDF2-50 cable

Product Classification

Product Type	Wireless and radiating connector
Product Brand	HELIAX®

General Specifications

Body Style	Straight
Cable Family	LDF2-50
Inner Contact Attachment Method	Captivated
Inner Contact Plating	Silver
Interface	7-16 DIN Male
Mounting Angle	Straight
Outer Contact Attachment Method	Self-flare
Outer Contact Plating	Silver
Pressurizable	No

Dimensions

Length	52.58 mm 2.07 in
Diameter	36.07 mm 1.42 in
Nominal Size	3/8 in

Outline Drawing

L2PDM-C

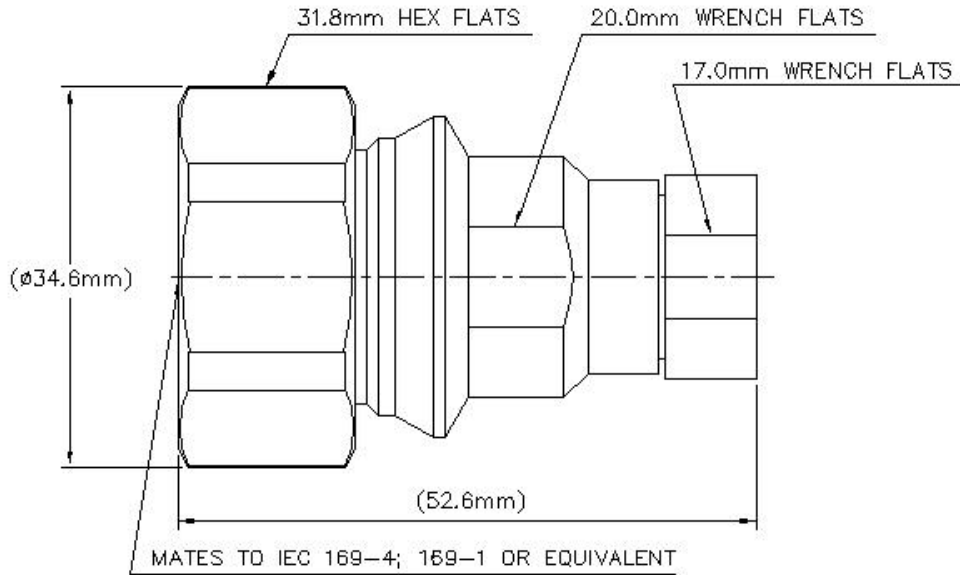

Electrical Specifications

3rd Order IMD at Frequency	-112 dBm @ 910 MHz
3rd Order IMD Test Method	Two +43 dBm carriers
Average Power at Frequency	0.7 kW @ 900 MHz
Cable Impedance	50 ohm
Connector Impedance	50 ohm
dc Test Voltage	2500 V
Inner Contact Resistance, maximum	0.4 mOhm
Insulation Resistance, minimum	10000 MOhm
Operating Frequency Band	0 – 6000 MHz
Outer Contact Resistance, maximum	1.5 mOhm
Peak Power, maximum	15.6 kW
RF Operating Voltage, maximum (vrms)	894 V
Shielding Effectiveness	-110 dB

Mechanical Specifications

Connector Retention Tensile Force	671.68 N 151 lbf
Connector Retention Torque	2.7 N-m 23.897 in lb
Coupling Nut Proof Torque	35 N-m 309.776 in lb

L2PDM-C

Coupling Nut Proof Torque Method	IEC 61169-16:9.3.11
Coupling Nut Retention Force	1000 N 224.81 lbf
Coupling Nut Retention Force Method	IEC 61169-16:9.3.11
Insertion Force	889.64 N 200 lbf
Insertion Force Method	IEC 61169-16:9.3.5
Interface Durability	500 cycles
Interface Durability Method	IEC 61169-4:17
Mechanical Shock Test Method	IEC 60068-2-27

Environmental Specifications

Operating Temperature	-55 °C to +85 °C (-67 °F to +185 °F)
Storage Temperature	-65 °C to +125 °C (-85 °F to +257 °F)
Attenuation, Ambient Temperature	20 °C 68 °F
Average Power, Ambient Temperature	40 °C 104 °F
Average Power, Inner Conductor Temperature	100 °C 212 °F
Corrosion Test Method	IEC 60068-2-11
Immersion Depth	1 m
Immersion Test Mating	Mated
Immersion Test Method	IEC 60529:2001, IP68
Moisture Resistance Test Method	IEC 60068-2-3
Thermal Shock Test Method	IEC 60068-2-14
Vibration Test Method	IEC 60068-2-6

Packaging and Weights

Weight, net	82 g 0.181 lb
--------------------	-----------------

* Footnotes

Immersion Depth	Immersion at specified depth for 24 hours
------------------------	---