

L4DR-PS

7-16 DIN Male Right Angle Positive Stop™ for 1/2 in LDF4-50A cable



Product Classification

Product Type	Wireless and radiating connector
Product Brand	HELIAX®
Product Series	LDF4-50A
Ordering Note	CommScope® standard product (Global)

General Specifications

Body Style	Right angle
Cable Family	LDF4-50A
Inner Contact Attachment Method	Captivated
Inner Contact Plating	Gold Silver
Interface	7-16 DIN Male
Mounting Angle	Right angle
Outer Contact Attachment Method	Self-flare
Outer Contact Plating	Trimetal
Pressurizable	No

Dimensions

Height	41.91 mm 1.65 in
Width	34.54 mm 1.36 in
Length	82.55 mm 3.25 in
Right Angle Length	18.29 mm 0.72 in
Nominal Size	1/2 in

Outline Drawing

L4DR-PS

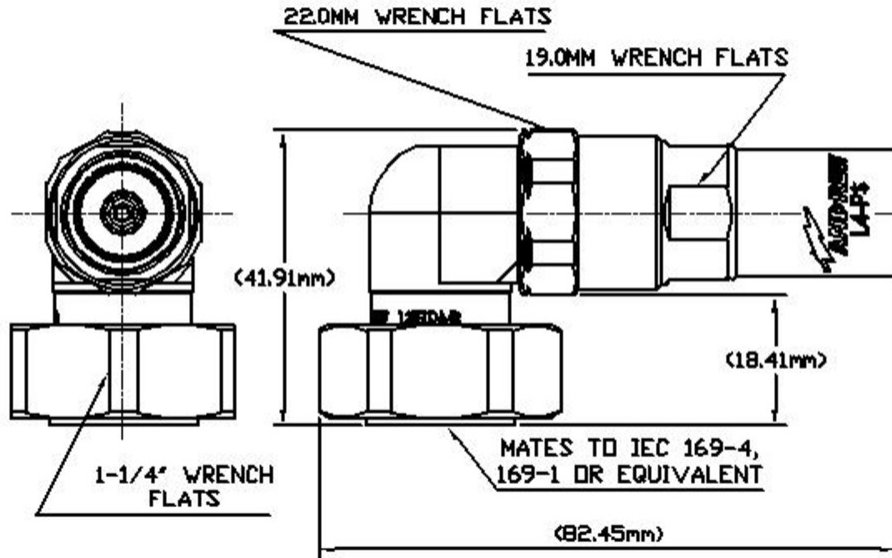

Electrical Specifications

3rd Order IMD at Frequency	-120 dBm @ 910 MHz
3rd Order IMD Test Method	Two +43 dBm carriers
Insertion Loss Coefficient, typical	0.05
Average Power at Frequency	1.0 kW @ 900 MHz
Cable Impedance	50 ohm
Connector Impedance	50 ohm
dc Test Voltage	2500 V
Inner Contact Resistance, maximum	0.8 mOhm
Insulation Resistance, minimum	5000 MOhm
Operating Frequency Band	0 – 7500 MHz
Outer Contact Resistance, maximum	1.5 mOhm
Peak Power, maximum	15.6 kW
RF Operating Voltage, maximum (vrms)	884 V
Shielding Effectiveness	-110 dB

VSWR/Return Loss

Frequency Band	VSWR	Return Loss (dB)
50–1000 MHz	1.018	41

L4DR-PS

1000–1900 MHz	1.03	36.61
1900–2200 MHz	1.058	31
2200–2700 MHz	1.07	29.42
2700–3600 MHz	1.09	27.32
3600–6000 MHz	1.19	21.24
6000–8800 MHz	1.671	12

Mechanical Specifications

Connector Retention Tensile Force	889.64 N 200 lbf
Connector Retention Torque	5.42 N-m 47.998 in lb
Coupling Nut Proof Torque	24.86 N-m 220.003 in lb
Coupling Nut Retention Force	1,000.85 N 225 lbf
Coupling Nut Retention Force Method	MIL-C-39012C-3.25, 4.6.22
Interface Durability	500 cycles
Interface Durability Method	IEC 61169-4:9.5
Mechanical Shock Test Method	MIL-STD-202F, Method 213B, Test Condition C

Environmental Specifications

Operating Temperature	-55 °C to +85 °C (-67 °F to +185 °F)
Storage Temperature	-55 °C to +85 °C (-67 °F to +185 °F)
Attenuation, Ambient Temperature	20 °C 68 °F
Average Power, Ambient Temperature	40 °C 104 °F
Corrosion Test Method	MIL-STD-1344A, Method 1001.1, Test Condition A
Immersion Depth	1 m
Immersion Test Mating	Unmated
Immersion Test Method	IEC 60529:2001, IP68
Moisture Resistance Test Method	MIL-STD-202F, Method 106F
Thermal Shock Test Method	MIL-STD-202F, Method 107G, Test Condition A-1, Low Temperature -55 °C
Vibration Test Method	MIL-STD-202F, Method 204D, Test Condition B
Water Jetting Test Mating	Unmated
Water Jetting Test Method	IEC 60529:2001, IP66

Packaging and Weights

L4DR-PS

Weight, net

166.9 g | 0.368 lb

Regulatory Compliance/Certifications

Agency

Classification

CHINA-ROHS

Above maximum concentration value

ISO 9001:2015

Designed, manufactured and/or distributed under this quality management system

ROHS

Compliant/Exempted

UK-ROHS

Compliant/Exempted



* Footnotes

Insertion Loss Coefficient, typical 0.05√freq (GHz) (not applicable for elliptical waveguide)

Immersion Depth Immersion at specified depth for 24 hours