

L4PNF

Type N Female for 1/2 in LDF4-50A cable



OBSOLETE

This product was discontinued on: May 18, 2019

Replaced By:

L4TNF-PSA

Type N Female Positive Stop™ for 1/2 in AL4RPV-50, LDF4-50A, HL4RPV-50 cable

Product Classification

Product Type	Wireless and radiating connector
Product Brand	HELIAX®

General Specifications

Body Style	Straight
Cable Family	LDF4-50A
Inner Contact Attachment Method	Solder
Inner Contact Plating	Gold
Interface	N Female
Mounting Angle	Straight
Outer Contact Attachment Method	Self-flare
Outer Contact Plating	Trimetal
Pressurizable	No

Dimensions

Length	66.04 mm 2.6 in
Diameter	22.86 mm 0.9 in
Nominal Size	1/2 in

L4PNF

Outline Drawing

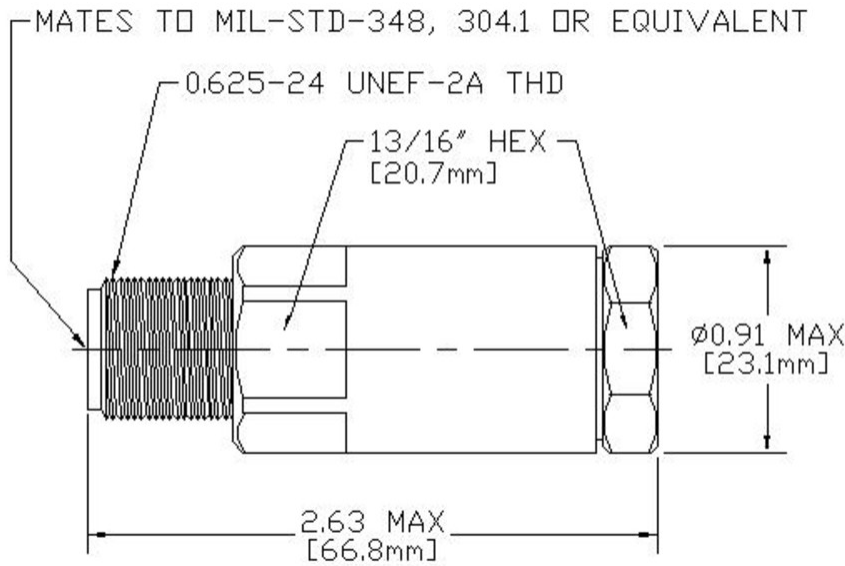

Electrical Specifications

Insertion Loss Coefficient, typical	0.05
Average Power at Frequency	0.6 kW @ 900 MHz
Cable Impedance	50 ohm
Connector Impedance	50 ohm
dc Test Voltage	2000 V
Inner Contact Resistance, maximum	2 mOhm
Insulation Resistance, minimum	5000 MOhm
Operating Frequency Band	0 – 8800 MHz
Outer Contact Resistance, maximum	0.3 mOhm
Peak Power, maximum	10 kW
RF Operating Voltage, maximum (vrms)	707 V
Shielding Effectiveness	-110 dB

VSWR/Return Loss

Frequency Band	VSWR	Return Loss (dB)
45–880 MHz	1.036	35.05
880–1800 MHz	1.083	27.99

L4PNF

1800–5300 MHz	1.119	25.01
5300–6200 MHz	1.152	23.02
6200–7000 MHz	1.222	20.01
7000–7900 MHz	1.33	17
7900–8800 MHz	1.5	14

Mechanical Specifications

Attachment Durability	25 cycles
Connector Retention Tensile Force	889.64 N 200 lbf
Connector Retention Torque	5.42 N-m 47.998 in lb
Interface Durability	500 cycles
Interface Durability Method	IEC 61169-16:9.5
Mechanical Shock Test Method	MIL-STD-202, Method 213, Test Condition I

Environmental Specifications

Operating Temperature	-40 °C to +85 °C (-40 °F to +185 °F)
Storage Temperature	-40 °C to +85 °C (-40 °F to +185 °F)
Attenuation, Ambient Temperature	20 °C 68 °F
Average Power, Ambient Temperature	40 °C 104 °F
Corrosion Test Method	MIL-STD-1344A, Method 1001.1, Test Condition A
Immersion Depth	1 m
Immersion Test Mating	Mated
Immersion Test Method	IEC 60529:2001, IP68
Moisture Resistance Test Method	MIL-STD-202F, Method 106F
Thermal Shock Test Method	MIL-STD-202F, Method 107G, Test Condition A-1, Low Temperature -55 °C
Vibration Test Method	MIL-STD-202F, Method 204D, Test Condition B

Packaging and Weights

Weight, net	68 g 0.15 lb
--------------------	----------------

Regulatory Compliance/Certifications

Agency	Classification
CHINA-ROHS	Below maximum concentration value
ISO 9001:2015	Designed, manufactured and/or distributed under this quality management system

L4PNF

REACH-SVHC	Compliant as per SVHC revision on www.commscope.com/ProductCompliance
ROHS	Compliant
UK-ROHS	Compliant



* Footnotes

Insertion Loss Coefficient, typical 0.05√freq (GHz) (not applicable for elliptical waveguide)

Immersion Depth Immersion at specified depth for 24 hours