

RT-ST

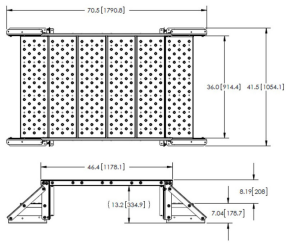

Rooftop Cable Tray Step Over

Product Classification

Product Type Step over

General Specifications

Cable Runs, quantity 0

Mounting Non-penetrating

Dimensions

Height 335.28 mm | 13.2 in

Width 1,054.1 mm | 41.5 in

Length 1,790.7 mm | 70.5 in

Outline Drawing

RT-ST

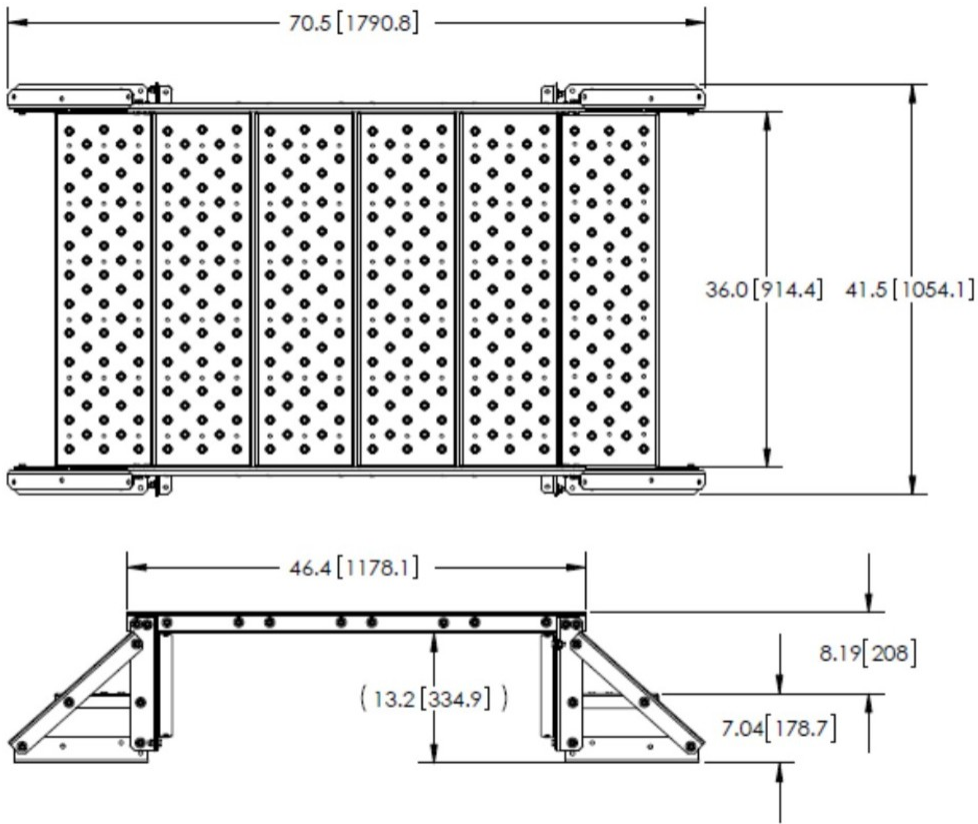

Material Specifications

Material Type Hot dip galvanized steel

Mechanical Specifications

Wind Rating For Specifications, please contact your local ANDREW representative

Packaging and Weights

Included Hardware | Step over

Packaging quantity 1

Weight, net 66.4 kg | 146.387 lb

Regulatory Compliance/Certifications

Agency

CHINA-ROHS

ISO 9001:2015

Classification

Above maximum concentration value

Designed, manufactured and/or distributed under this quality management system

RT-ST

ROHS Compliant/Exempted

UK-ROHS Compliant/Exempted



* Footnotes

Wind Rating

BWS—Base Wind Speed; FBC—Florida Building Code