

| REVISIONS |  |             |           |
|-----------|--|-------------|-----------|
| REV.      | DESCRIPTION  | DATE        | APPROVED  |
| A         | ECR 11543PC: RELEASE TO PRODUCTION PER EAO 608266. | 07APR21 SHL | WSD / YZW |

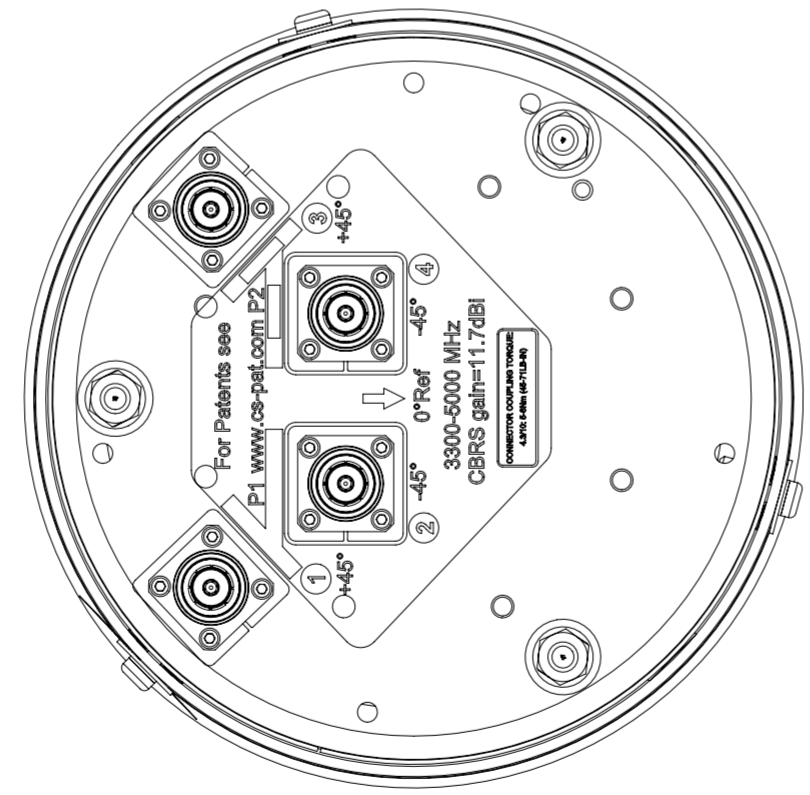

UU-360S-F

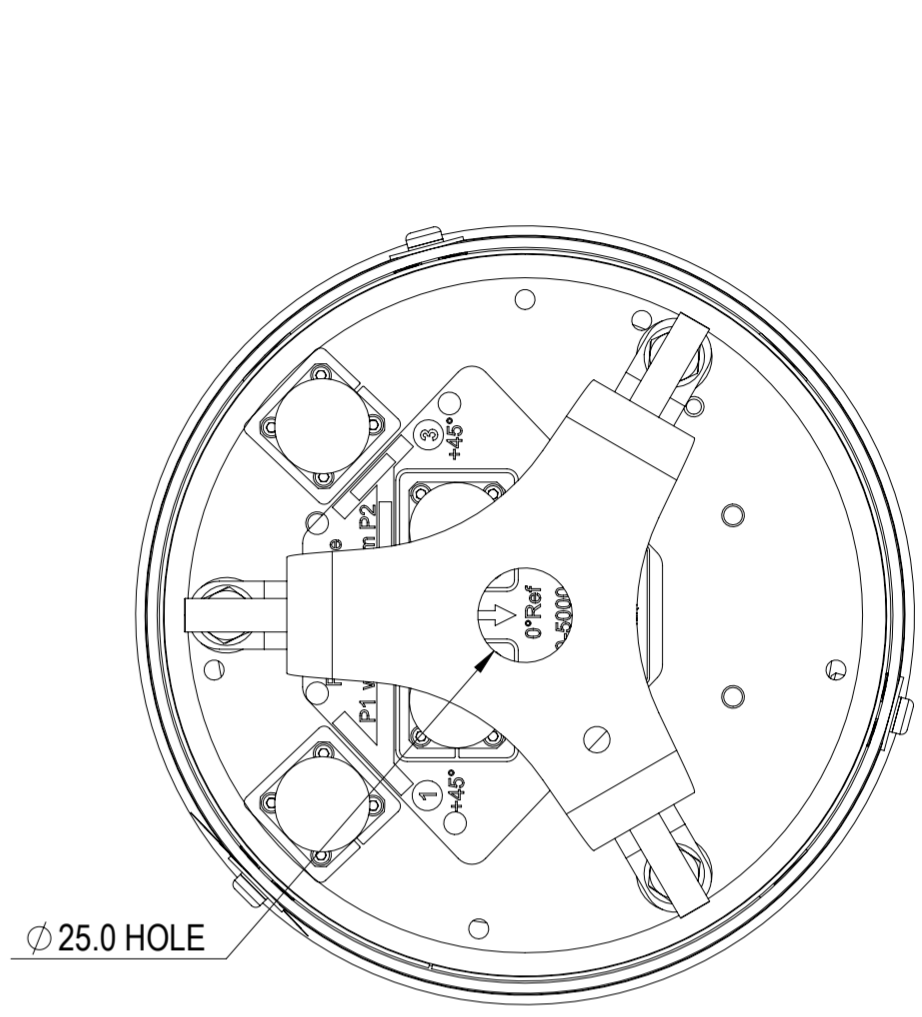

VIEW A-A  
BRACKET NOT SHOWN

|              |                   |
|--------------|-------------------|
| DENSITY      | g/mm <sup>3</sup> |
| MASS         | grams             |
| VOLUME       | mm <sup>3</sup>   |
| SURFACE AREA | mm <sup>2</sup>   |
| HEIGHT       |                   |
| LENGTH       |                   |
| WIDTH        |                   |

|   |            |               |            |                                 |                     |         |        |          |        |
|---|------------|---------------|------------|---------------------------------|---------------------|---------|--------|----------|--------|
| <b>COMMScope, INC. OF NORTH CAROLINA</b>  |            |               |            |                                 |                     |         |        |          |        |
| TOLERANCES  |            |               |            |                                 | SAP MATERIAL MASTER |         |        |          |        |
| 0 PLACE X ±   |            | 2 PLACE .XX ± |            |                                 |                     |         |        |          |        |
| 1 PLACE .X ±  |            | ANGLES ±      |            |                                 |                     |         |        |          |        |
| FINISH  |            |               |            |                                 | MATERIAL            |         |        |          |        |
| <b>PRODUCT DRAWING</b>  |            |               |            |                                 |                     |         |        |          |        |
| UNLESS OTHERWISE SPECIFIED<br>DIMENSIONS ARE IN MILLIMETERS<br>INTERPRET PER ISO STANDARDS<br>HANDBOOK TECHNICAL DRAWINGS,<br>VOLUMES 1 & 2, THIRD EDITION (2002) |            | NAME          | DATE       | TITLE                           |                     |         |        |          |        |
|   |            | CE HSANG      | 04/07/2021 | DOCUMENT NO. <b>UU-360S-F-L</b> |                     |         |        |          |        |
|   |            | RW HSANG      | 04/06/2021 |                                 |                     |         |        |          |        |
|   |            | RV            |            |                                 |                     |         |        |          |        |
|   |            | AD IWANG1     | 04/06/2021 |                                 |                     |         |        |          |        |
| RE ZHHCHEN  | 04/07/2021 |               |            |                                 |                     |         |        |          |        |
| ECN 11543PC   |            | SCALE         | 1:2        |                                 |                     |         |        |          |        |
| SIZE  | WORK AREA  | BSA           | MODEL      |                                 |                     | DRAWING |        |          | SHEET  |
| <b>A2</b>   |            |               | VERSION    | STATUS                          | REVISION            | VERSION | STATUS | REVISION | 1 OF 1 |
|   |            |               | 01         | RE                              | B                   | 00      | RE     | A        |        |