

# WP-198

---

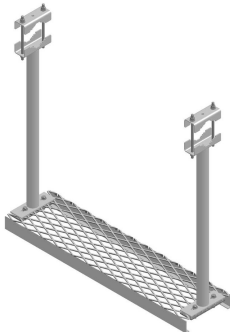

Work Platform for Double Pipe Support Arm

## Product Classification

**Product Type** Work platforms for support arm

## Dimensions

**Height** 990.6 mm | 39 in

**Platform Width** 304.8 mm | 12 in

**Width** 1016 mm | 40 in

**Length** 304.8 mm | 12 in

# WP-198

## Outline Drawing

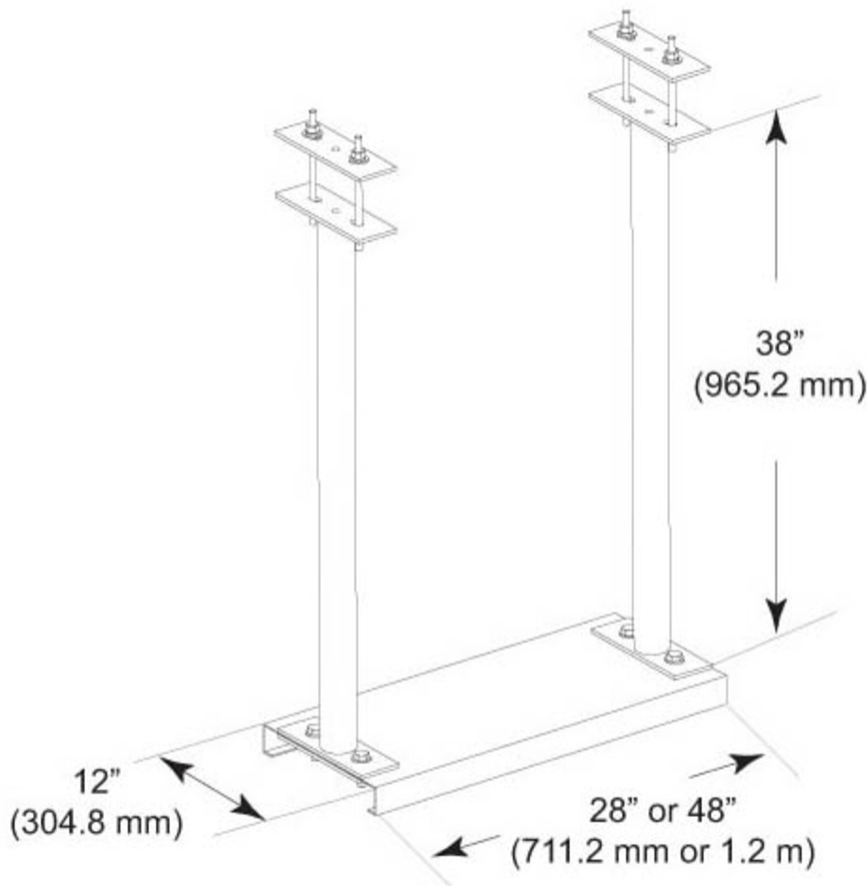

## Material Specifications

**Material Type** Hot dip galvanized steel

## Packaging and Weights

**Included** Clamps | Grating | Hardware

**Packaging quantity** 1

**Weight, net** 41.8 kg | 92.153 lb

## Regulatory Compliance/Certifications

**Agency** **Classification**

# WP-198

---

ISO 9001:2015

Designed, manufactured and/or distributed under this quality management system

