

APT-HFHM-CB

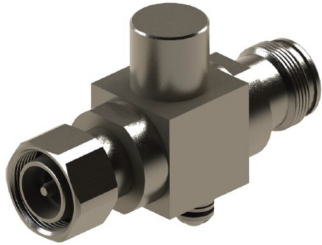

Quarterwave Surge Arrester for C-Band 3400-4000MHz, with interface types 4.3-10 Female and 4.3-10 Male

Product Classification

Product Type Surge arrester

General Specifications

Device Type dc Pass

Inner Contact Plating Silver

Interface 4.3-10 Female

Interface 2 4.3-10 Male

Outer Contact Plating Trimetal

Dimensions

Height 48.5 mm | 1.909 in

Width 25 mm | 0.984 in

Length 79.1 mm | 3.114 in

Outline Drawing

APT-HFHM-CB

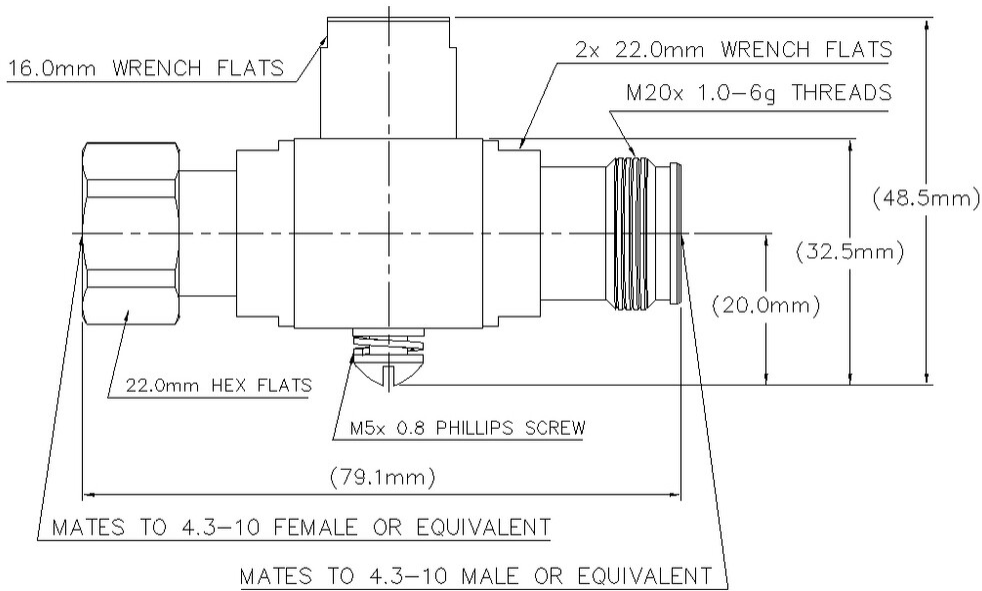

Electrical Specifications

3rd Order IMD Gain	-117 dB
3rd Order IMD Test Method	Two +43 dBm carriers
Insertion Loss, typical	0.15 dB
Connector Impedance	50 ohm
Inner Contact Resistance, maximum	1 mOhm
Lightning Surge Current	10 kA
Lightning Surge Current Waveform	8/20 waveform
Operating Frequency Band	3400 – 4000 MHz
Outer Contact Resistance, maximum	1 mOhm

VSWR/Return Loss

Frequency Band	VSWR	Return Loss (dB)	VSWR, typical	Return Loss, typical (dB)
3400-4000 MHz	1.2	20.83	1.065	30

Mechanical Specifications

Coupling Nut Proof Torque	88.507 in lb 10 N-m
----------------------------------	-----------------------

APT-HFHM-CB

Coupling Nut Retention Force	449.27 N 101 lbf
Coupling Nut Retention Force Method	MIL-C-39012C-3.25, 4.6.22
Interface Durability	100 cycles
Interface Durability Method	IEC 61169-16:9.5
Mechanical Shock Test Method	IEC 61169-1 9.3.14

Environmental Specifications

Operating Temperature	-45 °C to +85 °C (-49 °F to +185 °F)
Storage Temperature	-55 °C to +85 °C (-67 °F to +185 °F)
Attenuation, Ambient Temperature	20 °C 68 °F
Average Power, Ambient Temperature	40 °C 104 °F
Corrosion Test Method	IEC 60068-2-11
Immersion Depth	1 m
Immersion Test Mating	Mated
Immersion Test Method	IEC 60529:2001, IP68
Moisture Resistance Test Method	IEC 60068-2-3
Thermal Shock Test Method	IEC 60068-2-14

Packaging and Weights

Packaging quantity	50
Weight, net	0.238 kg 0.525 lb

* Footnotes

Insertion Loss, typical	0.15√freq (GHz) (not applicable for elliptical waveguide)
Immersion Depth	Immersion at specified depth for 24 hours