

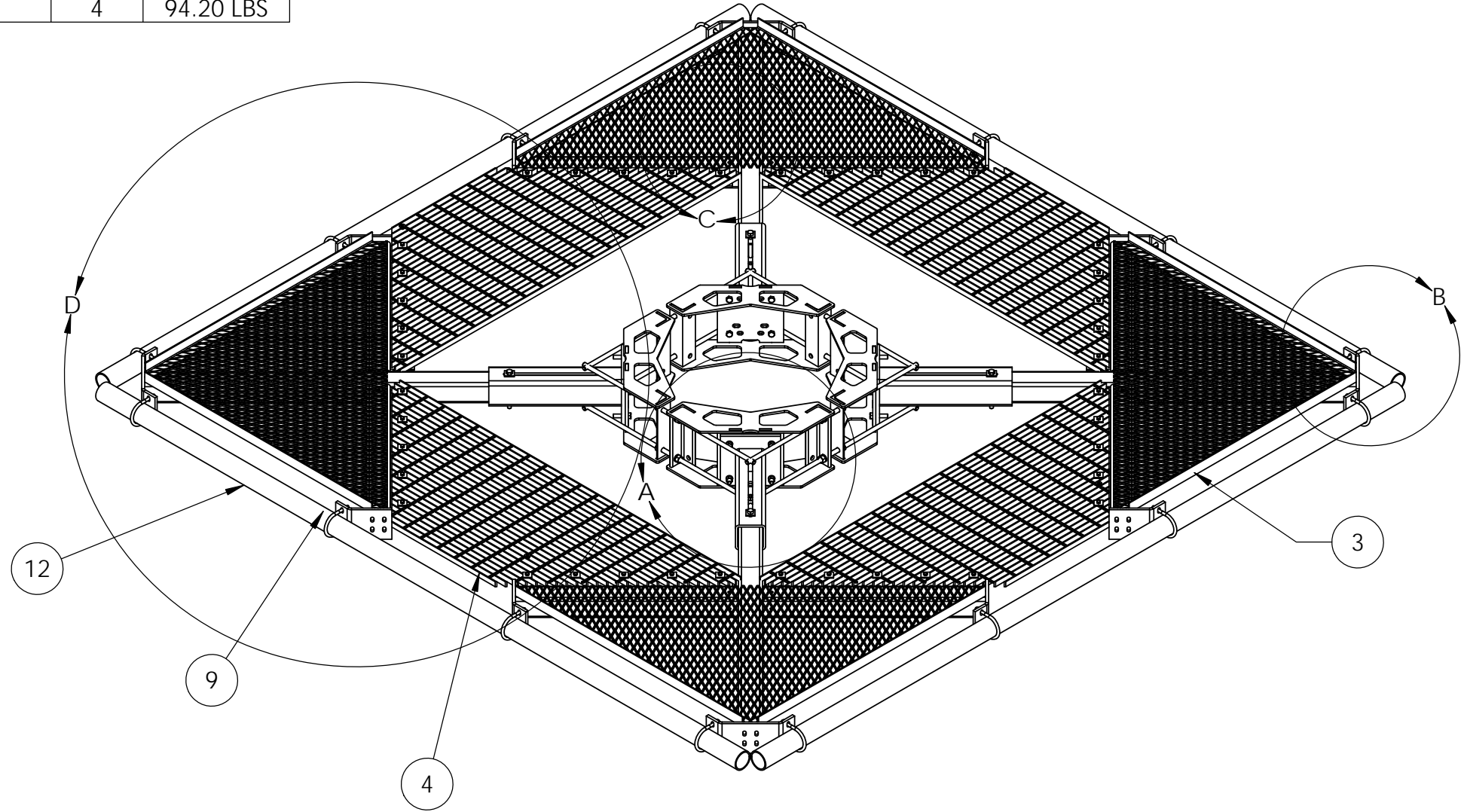

| ITEM | PART NO.    | DESCRIPTION                                   | QTY. | WEIGHT     |
|------|-------------|---|------|------------|
| 1    | MC-RM3060-4 | FOUR SECTOR RING MOUNT, 30-60 OD              | 1    | 255.01 LBS |
| 2    | MTC820122   | Slider Base 30"-60"                           | 4    | 55.95 LBS  |
| 3    | MTC820121   | Platform Weldment                             | 4    | 253.00 LBS |
| 4    | MTC820131   | Platform Grate                                | 4    | 80.74 LBS  |
| 5    | MT-387      | SQUARE WASHER, 1-1/2" X 1-1/2" W/ 7/16" HOLE  | 40   | 0.11 LBS   |
| 6    | GWF-03      | 3/8" GALV FLAT WASHER                         | 40   | 0.01 LBS   |
| 7    | GB-03225    | 3/8" X 2-1/4" GALV BOLT KIT                   | 40   | 0.09 LBS   |
| 8    | GB-0524A    | 5/8" X 2-1/2" GALV BOLT KIT (A325)            | 16   | 0.30 LBS   |
| 9    | GUB-4355    | 1/2" X 3-5/8" X 5" GALV U-BOLT                | 16   | 0.70 LBS   |
| 10   | MT389       | SQUARE WASHER, 1-1/2" X 1-5/8" W/ 11/16" HOLE | 8    | 0.11 LBS   |
| 11   | GB-0570A    | 5/8" X 7" GALV BOLT KIT A325                  | 4    | 0.69 LBS   |
| 12   | MT21601     | Ø 3.5" O.D. X 150" PIPE                       | 4    | 94.20 LBS  |

| REVISIONS |            |                 |     |          |
|-----------|------------|-----------------|-----|----------|
| REV.      | ECN        | DESCRIPTION     | BY  | DATE     |
| A         |            | INITIAL RELEASE | MSM | 10/18/12 |
| B         | 8000015106 | NEW RINGMOUNT   | MSM | 07/13/16 |



NOTES:  
 1. ALL METRIC DIMENSIONS ARE IN BRACKETS.

|   |   |  |   |
|---|---|--|---|
| <small>These drawings and specifications are the proprietary property of ANDREW CORPORATION and may be used only for the specific purpose authorized in writing by Andrew Corporation.</small><br><small>ALL DIMENSIONS ARE IN INCHES U.O.S.</small><br><small>TOLERANCES UNLESS OTHERWISE SPECIFIED:</small><br>.X = ± .12      ANGLES      ±2°<br>.XX = ± .06      FRACTIONS      ±1/32<br>.XXX = ± .03<br><small>REMOVE BURRS AND BREAK EDGES .005</small><br><b>DO NOT SCALE THIS PRINT</b> | <small>DRAWN BY:</small><br><b>MSM</b>  | <small>SHEET:</small><br>1 of 4                                | <small>PART NUMBER:</small><br><b>MC-PK12L4-B</b>                                     |
|   | <small>CHECKED BY:</small><br><b>TP</b> | <small>SCALE:</small><br>NTS                                   | <small>DESCRIPTION:</small><br>12'6" 4-SECTOR PLATFORM BASE, 30"-60" Pole             |
|   | <small>DATE:</small><br>10/18/12        | <small>MATERIAL:</small><br>A36, A53, A500                     | <small>DRAWING TYPE:</small><br>ASSEMBLY DRAWING                                      |
|   | <small>REVISION:</small><br><b>B</b>    | <small>FINISH:</small><br>GALV A123                            |  |
|   | <small>WEIGHT:</small><br>2221.32 LBS   | <small>WESTCHESTER, IL. 60154</small><br><small>U.S.A.</small> |   |

Ø 60 [1524.0]  
30 [762.0]

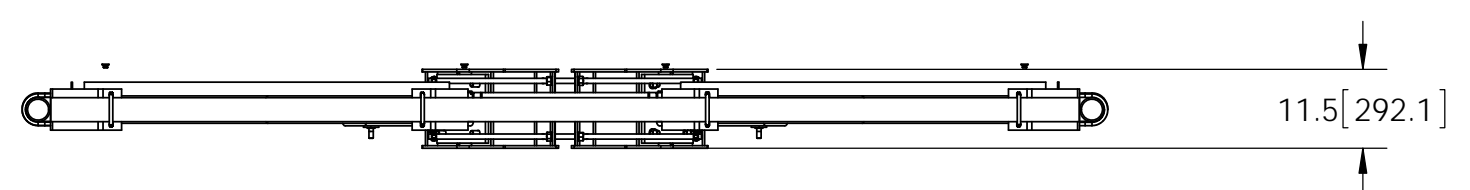
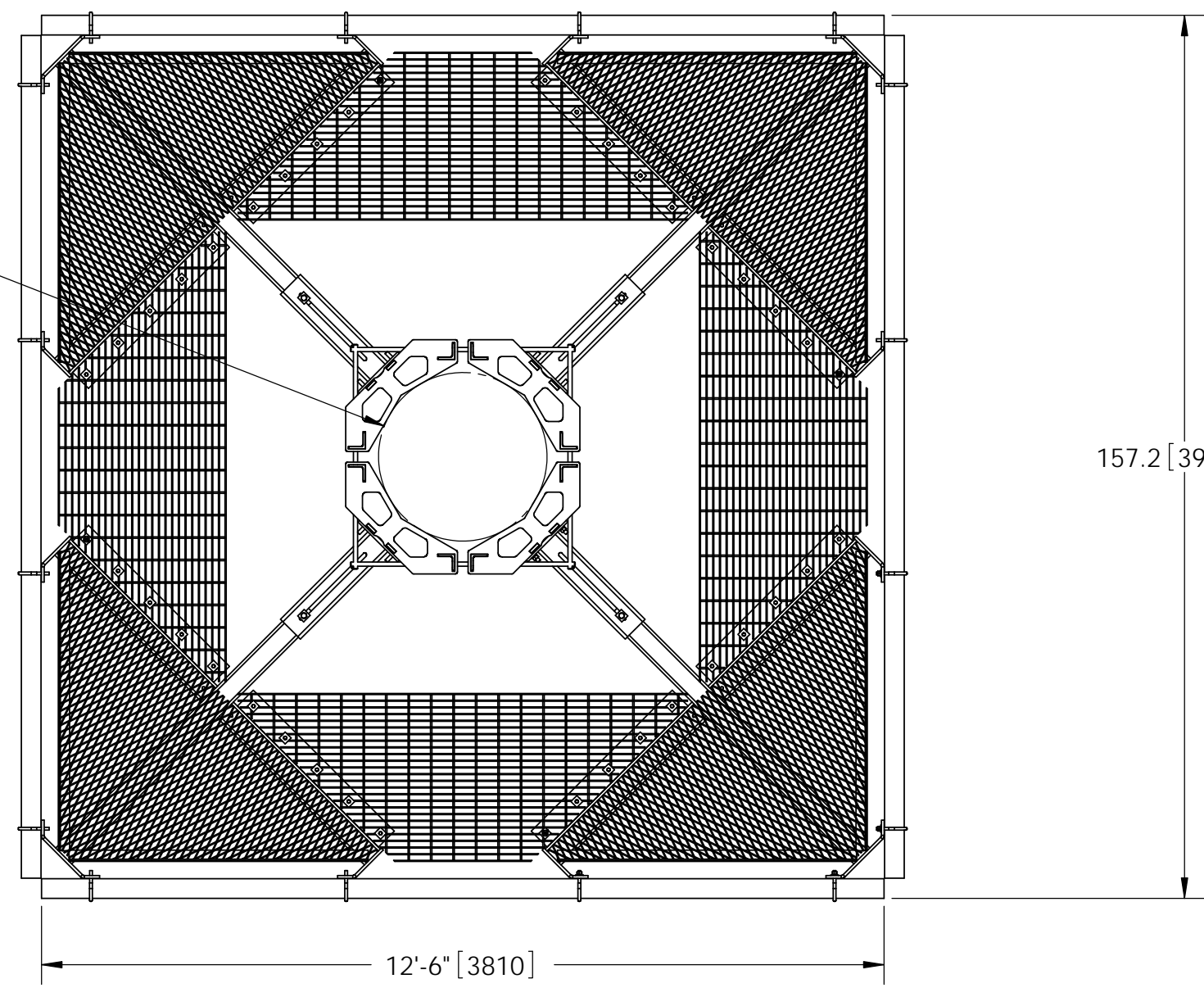

NOTES:  
1. ALL METRIC DIMENSIONS ARE IN BRACKETS.

These drawings and specifications are the proprietary property of ANDREW CORPORATION and may be used only for the specific purpose authorized in writing by Andrew Corporation.

ALL DIMENSIONS ARE IN INCHES U.O.S.  
TOLERANCES UNLESS OTHERWISE SPECIFIED:  
.X = ± .12      ANGLES      ±2°  
.XX = ± .06      FRACTIONS      ±1/32  
.XXX = ± .03

REMOVE BURRS AND BREAK EDGES .005

DO NOT SCALE THIS PRINT

|                       |                             |  |
|-----------------------|-----------------------------|--|
| DRAWN BY:<br>MSM      | SHEET:<br>2 of 4            | PART NUMBER:<br>MC-PK12L4-B                                |
| CHECKED BY:<br>TP     | SCALE:<br>NTS               | DESCRIPTION:<br>12'6" 4-SECTOR PLATFORM BASE, 30"-60" Pole |
| DATE:<br>10/18/12     | MATERIAL:<br>A36, A53, A500 | DRAWING TYPE:<br>ASSEMBLY DRAWING                          |
| REVISION:<br><b>B</b> | FINISH:<br>GALV A123        |  |
|                       | WEIGHT:<br>2221.32 LBS      |  |



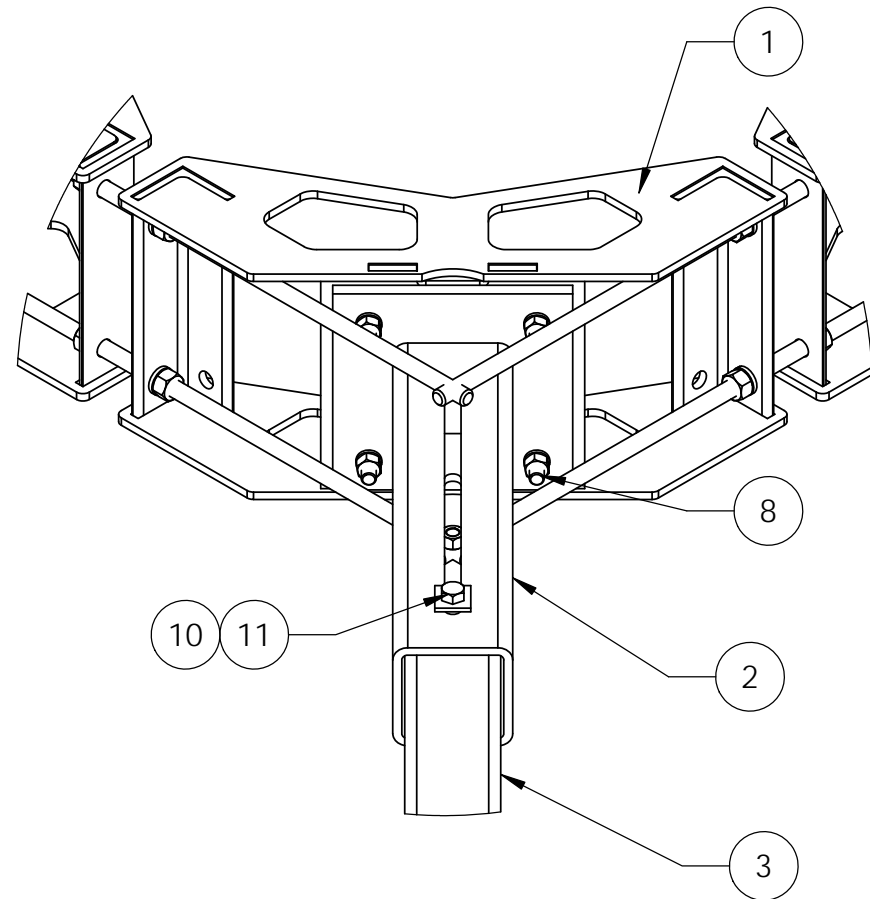

DETAIL A  
SCALE 1 : 8

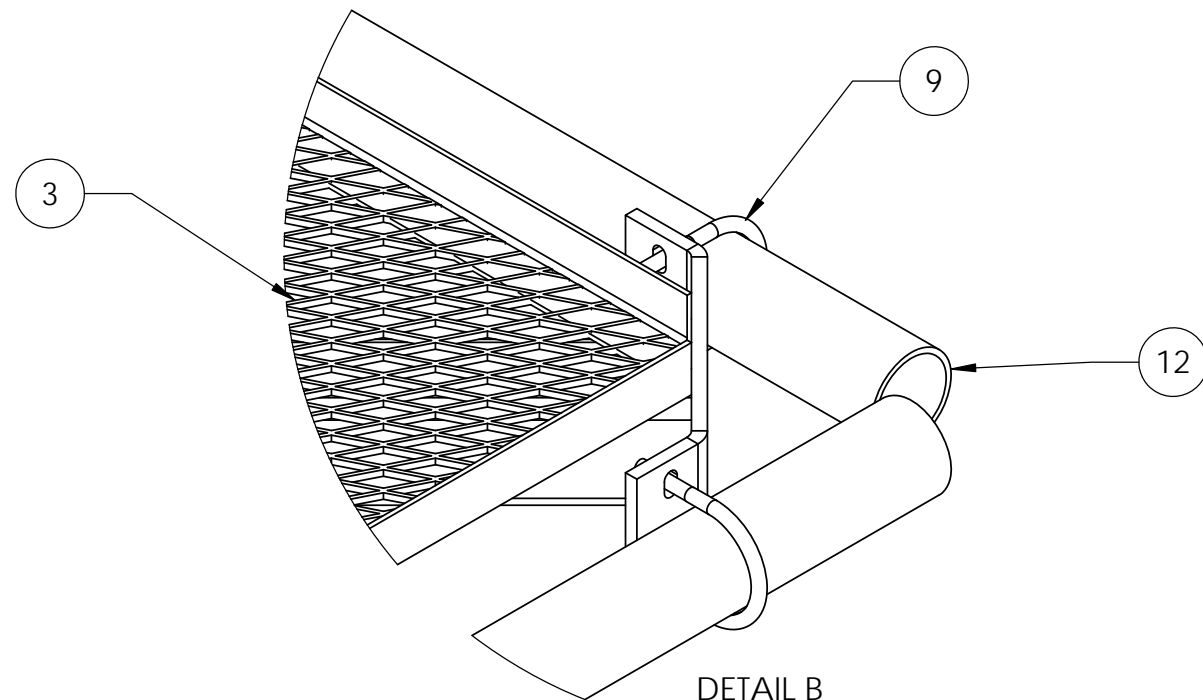

DETAIL B  
SCALE 1 : 6

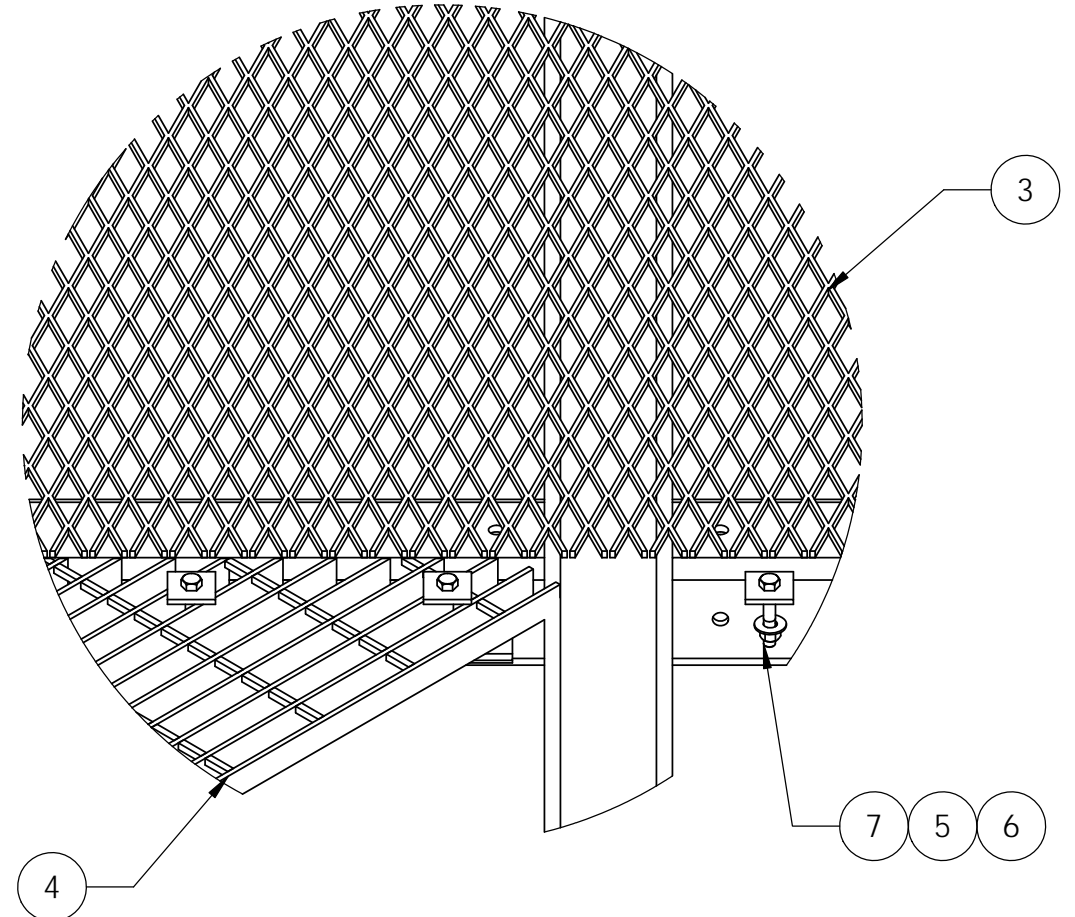

DETAIL C  
SCALE 1 : 6

|  |                               |                                     |  |
|--|-------------------------------|-------------------------------------|--|
| <p>These drawings and specifications are the proprietary property of ANDREW CORPORATION and may be used only for the specific purpose authorized in writing by Andrew Corporation.</p> <p>ALL DIMENSIONS ARE IN INCHES U.O.S.<br/>TOLERANCES UNLESS OTHERWISE SPECIFIED:</p> <p>.X = ± .12      ANGLES      ±2°<br/>.XX = ± .06      FRACTIONS      ±1/32<br/>.XXX = ± .03</p> <p>REMOVE BURRS AND BREAK EDGES .005</p> <p>DO NOT SCALE THIS PRINT</p> | <p>DRAWN BY:<br/>MSM</p>      | <p>SHEET:<br/>3 of 4</p>            | <p>PART NUMBER:<br/>MC-PK12L4-B</p>                                |
|  | <p>CHECKED BY:<br/>TP</p>     | <p>SCALE:<br/>NTS</p>               | <p>DESCRIPTION:<br/>12'6" 4-SECTOR PLATFORM BASE, 30"-60" Pole</p> |
|  | <p>DATE:<br/>10/18/12</p>     | <p>MATERIAL:<br/>A36, A53, A500</p> | <p>DRAWING TYPE:<br/>ASSEMBLY DRAWING</p>                          |
|  | <p>REVISION:<br/><b>B</b></p> | <p>FINISH:<br/>GALV A123</p>        | <p>WEIGHT:<br/>2221.32 LBS</p>                                     |



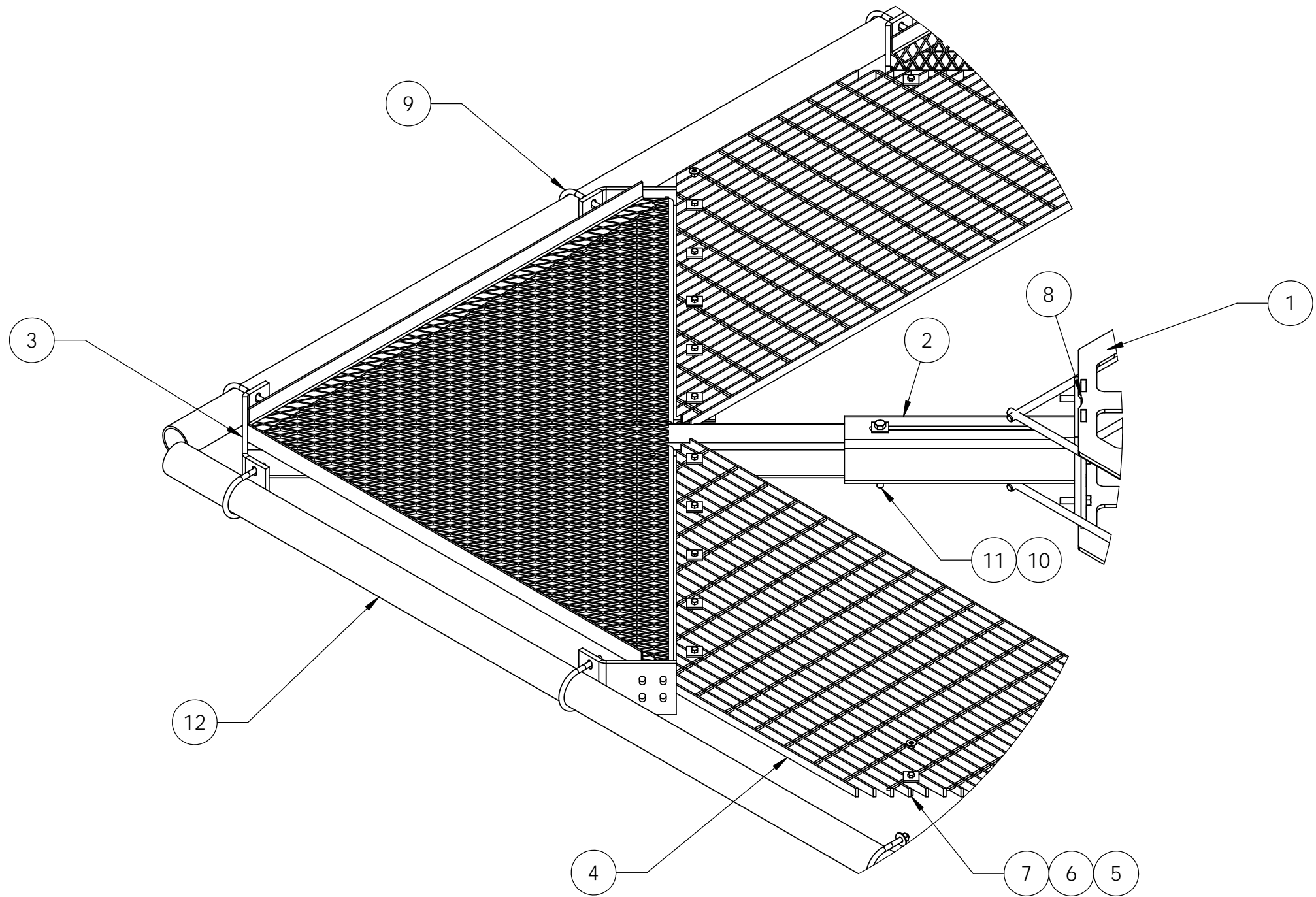

DETAIL D  
SCALE 1 : 12

|  |                               |   |  |
|--|-------------------------------|---|--|
| <p>These drawings and specifications are the proprietary property of ANDREW CORPORATION and may be used only for the specific purpose authorized in writing by Andrew Corporation.</p> <p>ALL DIMENSIONS ARE IN INCHES U.O.S.<br/>TOLERANCES UNLESS OTHERWISE SPECIFIED:</p> <p>.X = ± .12      ANGLES      ±2°<br/>.XX = ± .06      FRACTIONS      ±1/32<br/>.XXX = ± .03</p> <p>REMOVE BURRS AND BREAK EDGES .005</p> <p>DO NOT SCALE THIS PRINT</p> | <p>DRAWN BY:<br/>MSM</p>      | <p>SHEET:<br/>4 of 4</p>                                    | <p>PART NUMBER:<br/>MC-PK12L4-B</p>  |
|  | <p>CHECKED BY:<br/>TP</p>     | <p>SCALE:<br/>NTS</p>                                       | <p>DESCRIPTION:<br/>12'6" 4-SECTOR PLATFORM BASE, 30"-60" Pole</p>   |
|  | <p>DATE:<br/>10/18/12</p>     | <p>MATERIAL:<br/>A36, A53, A500</p>                         | <p>DRAWING TYPE:<br/>ASSEMBLY DRAWING</p>  |
|  | <p>REVISION:<br/><b>B</b></p> | <p>FINISH:<br/>GALV A123</p> <p>WEIGHT:<br/>2221.32 LBS</p> |  <p>WESTCHESTER, IL. 60154<br/>U.S.A.</p> |