

NOTES:

- 1.0 GENERAL NOTES
 - 1.1 ALL METRIC DIMENSIONS ARE IN BRACKETS [X. X]
 - 1.2 MARK PART WITH IDENTIFICATION NUMBER
 - 1.3 FOR PATENT INFO: <https://www.cs-pat.com>
- 2.0 DESIGN NOTES
- 3.0 MANUFACTURING/SPECIAL REQUIREMENTS
 - 3.1 TIGHTEN ALL BOLTS SECURING FLAT PLATES BY THE TURN-OF-NUT METHOD. TIGHTEN ALL U-BOLTS USING TURN-OF-NUT METHOD WITH ATTENTION TO LEAVE EQUAL DISTANCE AND EQUAL FORCE ON EACH LEG OF THE U-BOLT.
- 4.0 TEST
- 5.0 PACKAGING
 - 5.1 PACKAGING SHALL MEET COMMScope REQUIREMENTS PER DOCUMENT IS-PL-3005
 - 5.2 PRINTED DOCUMENT TO BE PLACED INSIDE POLYBAG AND THEN IN SHIPPING CONTAINER
 - 5.3 EXTRA HARDWARE MAYBE SUPPLIED BAGGED AND SHIPPED

REVISIONS				
REV.	ECN	DESCRIPTION	BY	DATE
A	40139383CMO	INITIAL RELEASE	MAC	2021/11/15
B	40139383CMO	CHANGED THE BOM LIST	MAC	2021/12/16
C	40139383CMO	USE MT37916 INSTEAD OF MT-379-16	MAC	2022/1/25

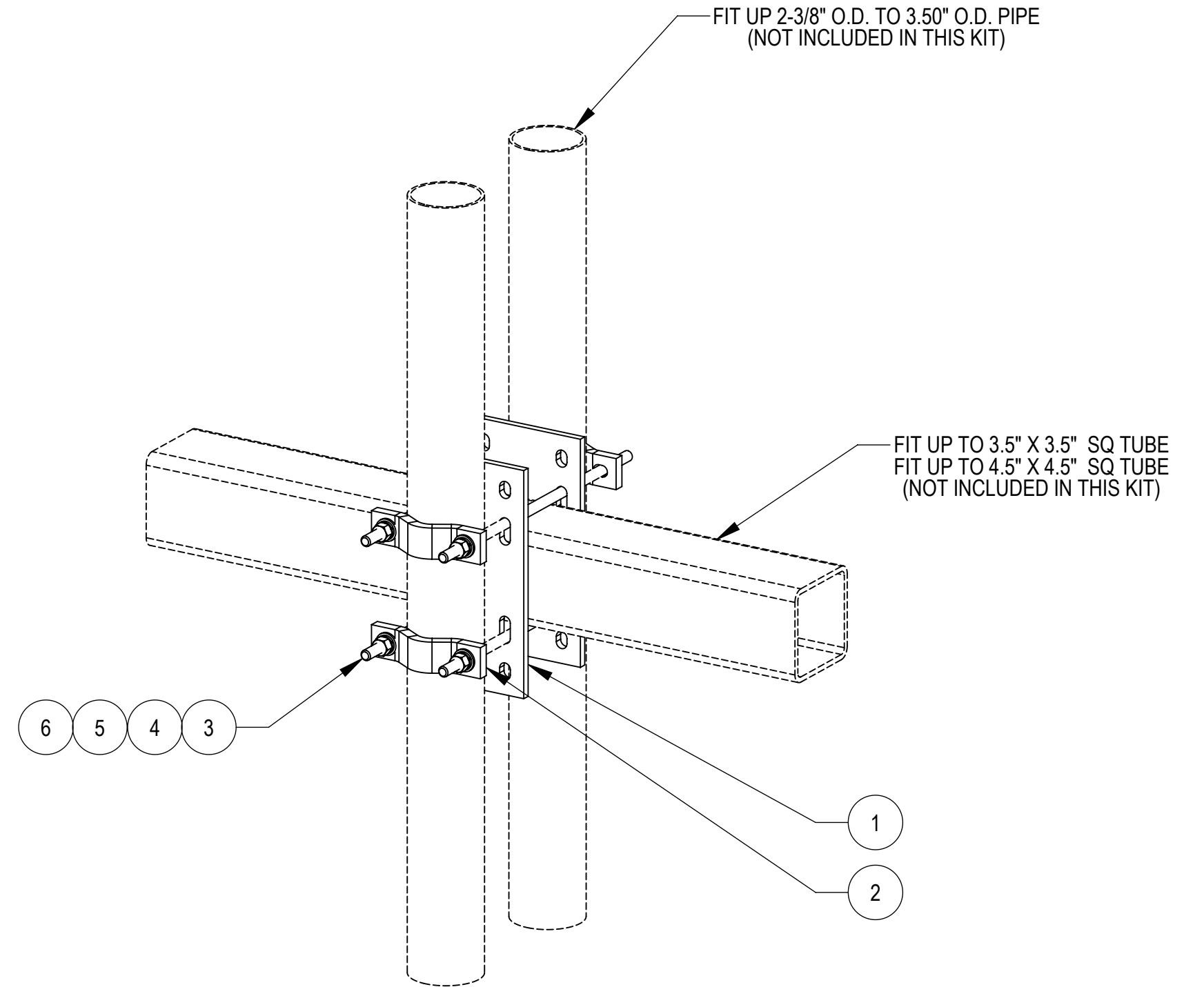
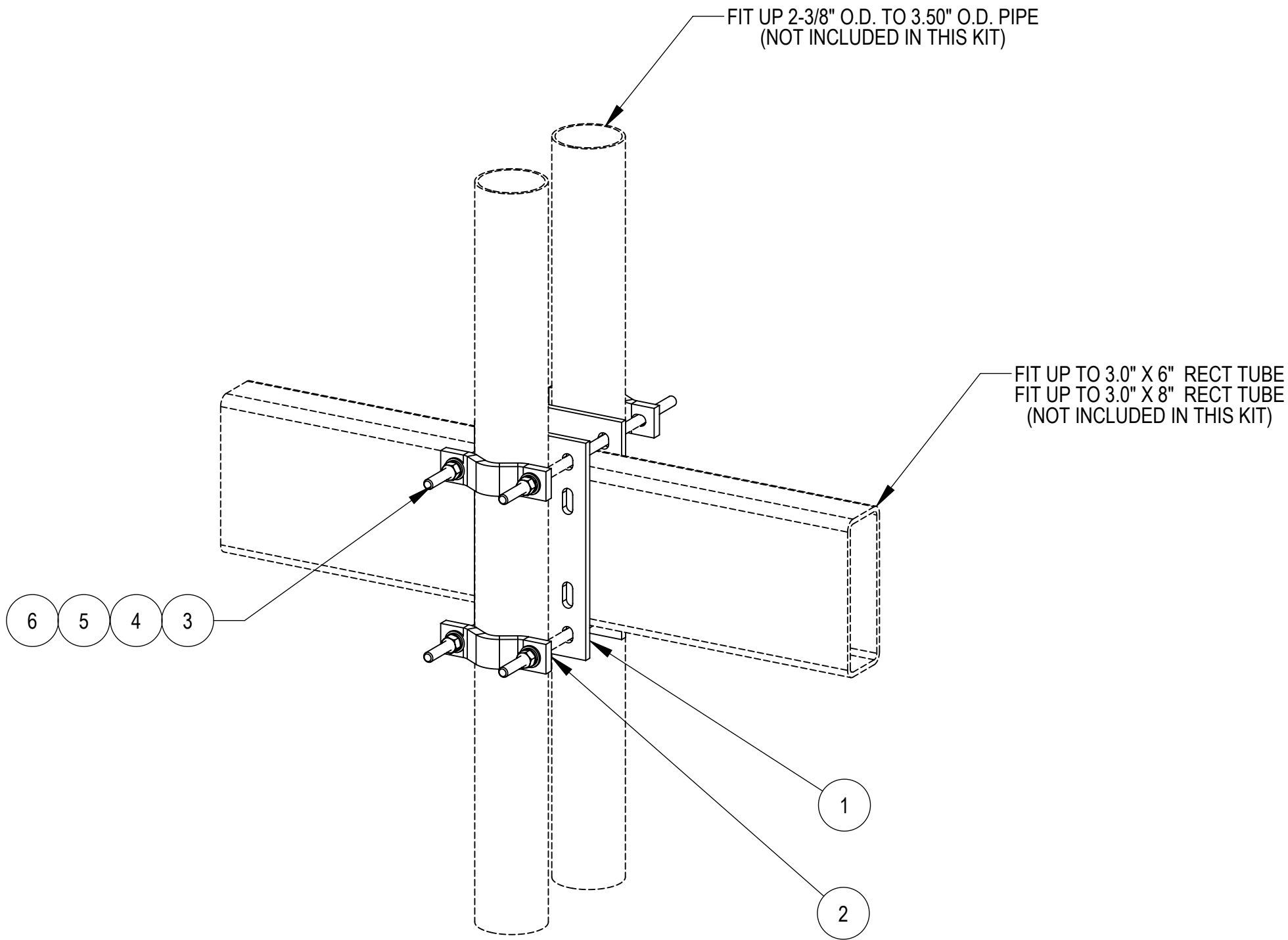

ITEM	PART NO.	DESCRIPTION	QTY.	WEIGHT	NOTE NO.
1	XP-PM-1000	BACKING PLATE	2	6.73 LBS	
2	SCP10	SMALL DISH CLAMP HALF	4	1.20 LBS	
3	MT37916	1/2" X 16" GALV THREADED ROD	4	0.89 LBS	
4	GWL-04	1/2" GALV LOCK WASHER	8	0.01 LBS	
5	GN-04	1/2" GALV HEX NUT	8	0.04 LBS	
6	GWF04A	1/2" GALV FLAT WASHER (A325)	8	0.02 LBS	

DENSITY	6.13	lbs/in ³
MASS	22.586	lbs
VOLUME	1078.88	in ³
SURFACE AREA	11	in ²
HEIGHT	6.13	
LENGTH	16	
WIDTH	11	

COMMScope, INC. OF NORTH CAROLINA

TOLERANCES		SAP MATERIAL MASTER						
1 PLACE .X ± 0.25	3 PLACE .XXX ± 0.06	XP-PM-D						
2 PLACE .XX ± 0.12	ANGLES ± 2°							
FINISH GALV A123		MATERIAL SEE BOM						
UNLESS OTHERWISE SPECIFIED DIMENSIONS ARE IN INCHES INTERPRET PER ANSI Y 14.5M-1994		TITLE MP RRU SUPPORT KIT, SINGLE RADIO PIPE						
CE	MAC	11/15/2021	XP-PM-D					
RW	MM1298	01/25/2022						
AD	BA1025	01/26/2022						
RE	MM1298	01/26/2022						
ECN 40139383CMO		SCALE 1:6	DOCUMENT NO.					
SIZE	Auth Group	INSL	MODEL					
C			VERSION	STATUS	REVISION	VERSION	STATUS	REVISION
			02	RE	C	02	RE	C
SHEET 1 OF 1								