

NOVUX™ Fiber Optic System FOSC 650

1 About this manual

This manual describes the installation steps of the FOSC 650. The document starts with providing an overview of the tools required to perform the installation. Also warnings and cautions are indicated, which should be observed before starting the product installation.

Images in this manual are for reference only and are subject to change.

2 General product information

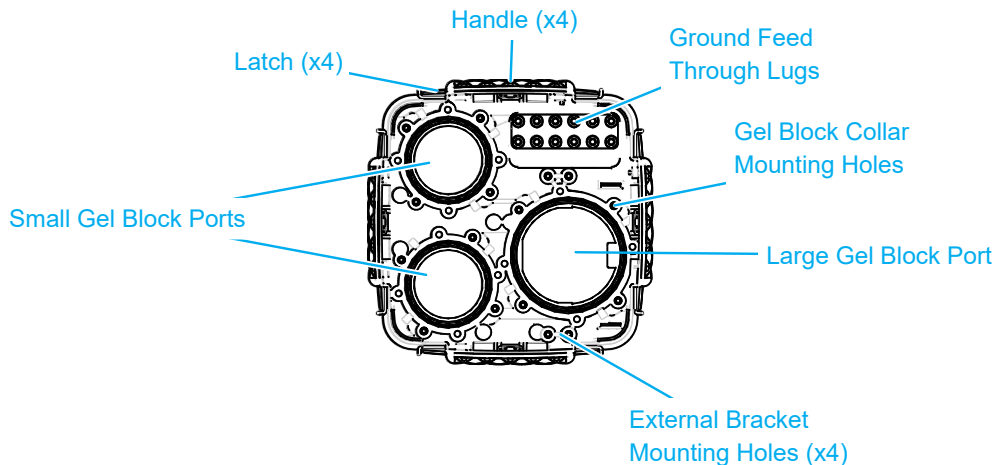
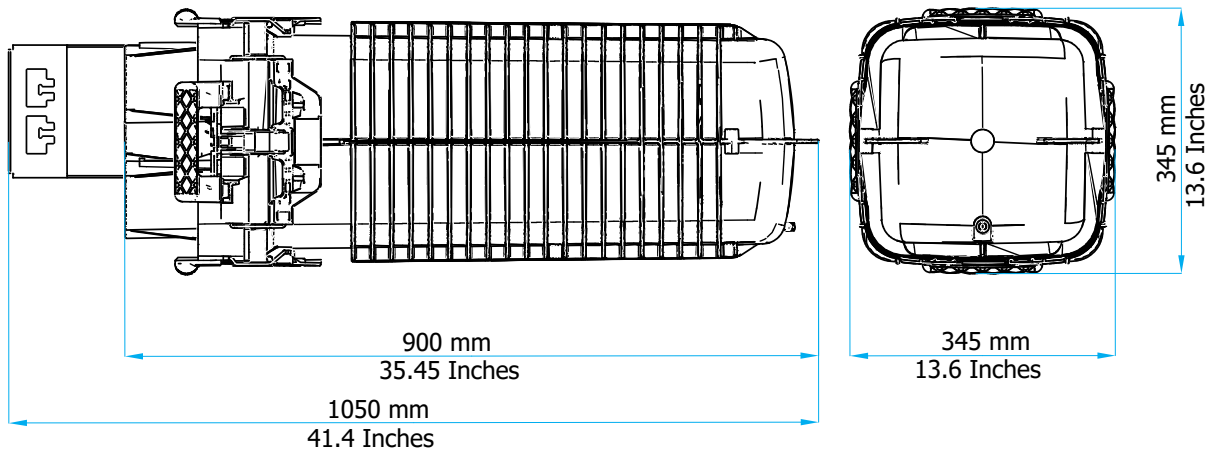

2.1 Dimensions

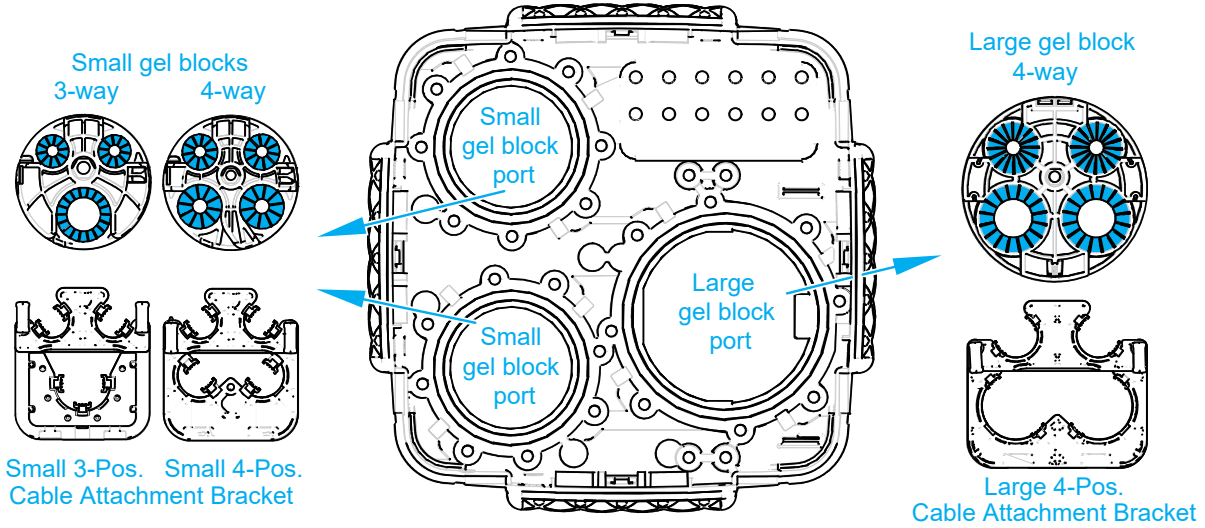

2.2 Cable diameter range

See the figure/table below to determine which cable diameter can be used in combination with which port/gel block.

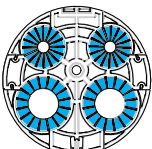

Gel Blocks	Small Cable Ports		Large Cable Port(s)	
	# Ports	Cable Outside Diameter Min. - Max.	# Ports	Cable Outside Diameter Min. - Max.
Small 3-way 	2	8 - 20 mm 0.32 - 0.79 inch	1	25 - 35 mm 1.0 - 1.38 inches
Small 4-way 	2	8 - 22 mm 0.32 - 0.87 inch	2	10 - 28 mm 0.39 - 1.1 inches
Large 4-way 	2	18 - 25 mm 0.7 - 1.0 inch	2	25 - 40 mm 1.0 - 1.6 inches

Note: Regarding the small 4-way cable gel block: if both lower cable ports have cable diameters greater than 26 mm / 1 inch, then the maximum cable diameter in the upper cable ports will be 20 mm / 0.79 inches.

Contents

1 About this manual.....	1	11.1 General product information.....	12
2 General product information.....	1	11.2 Tray dimensions.....	12
2.1 Dimensions.....	1	11.3 Tray installation.....	12
2.2 Cable diameter range.....	2	11.4 Tray support.....	13
3 Abbreviations.....	4	11.5 Route on tray.....	13
4 Tools.....	4	11.6 Splice Fibers and Store on Trays.....	14
5 Warnings and Cautions.....	4	12 Gel blocks.....	14
6 Open the closure.....	4	12.1 Install gel blocks.....	15
7 Closure preparation.....	5	13 Close the closure.....	17
7.1 Tray support tower.....	5	14 Testing the Closure Seal.....	17
7.2 Cable attachments assembly.....	5	15 Grounding.....	18
8 Cable preparation.....	6	16 External cable fixation.....	19
8.1 Remove Jacket.....	6	16.1 External cable fixation kit content.....	19
8.2 Strength member fixation.....	7	16.2 Installation external cable fixation bracket.....	19
9 Cable installation.....	8	17 Mount the closure.....	20
10 Routing.....	9	17.1 Wall mounting.....	20
10.1 Preparation.....	9	17.2 Aerial mounting.....	21
10.2 Route in basket.....	10	18 Disclaimer.....	23
11 Trays.....	12	19 Contact information.....	23

3 Abbreviations

FOSC: Fiber Optic Splice Closure

4 Tools

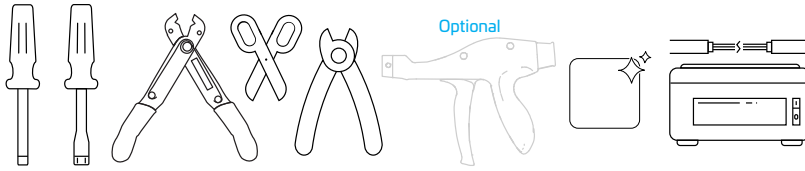

5 Warnings and Cautions

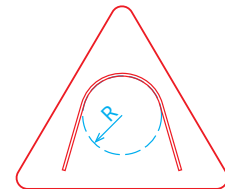
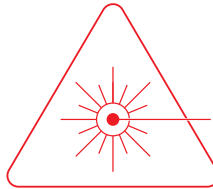
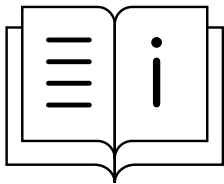

- Follow the installation instruction steps to ensure the performance of the closure. It is necessary to take precautions and keep the working space clean to protect the closure sealing materials and splices.
- Exposure to laser radiation can seriously damage the retina of the eye. Do not look into the ends of any optical fiber. Do not assume the laser power is turned off or that the fiber is disconnected at the other end. Looking into the ends of any optical fiber is entirely at your own risk. A protective cap or hood **MUST** be immediately placed over any radiating adapter or optical fiber connector to avoid the potential of dangerous amounts of radiation exposure. This practice also prevents dirt particles from entering the connector and adapter.
- Fiber optic cables may be damaged if bent or curved to a radius that is less than the recommended minimum bend radius. Always observe the recommended bend radius limit when installing fiber optic cables, subunits and patch cords.

6 Open the closure

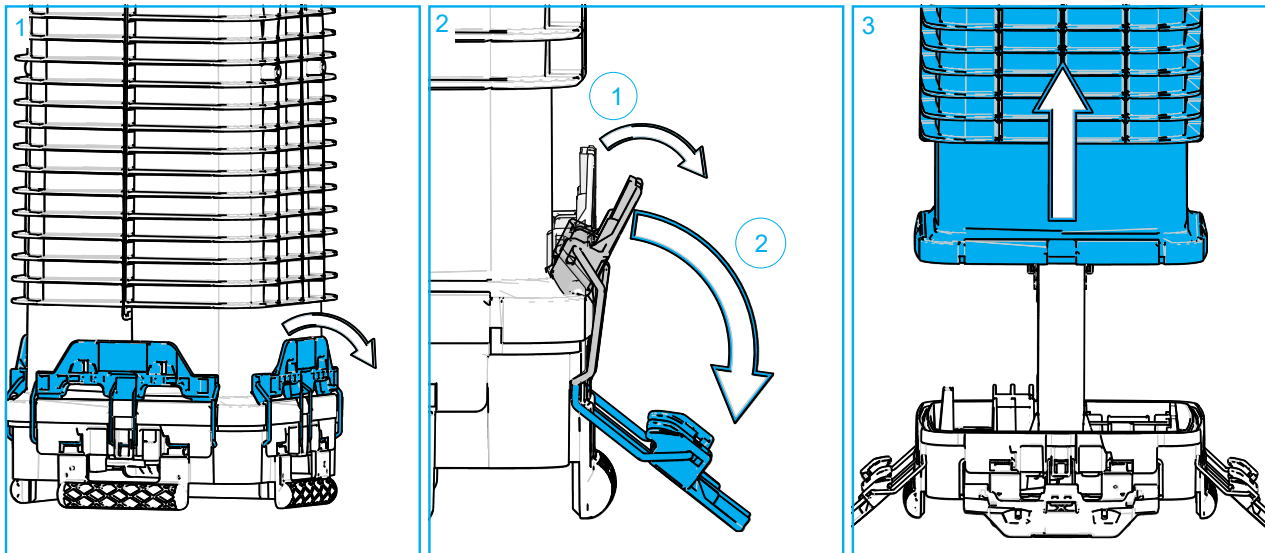

- 1 Open the latch by pulling downwards.
- 2 Then turn the latch down.
- 3 Open the 4 latches and lift the dome away from the base and set aside until the end of the installation.

7 Closure preparation

7.1 Tray support tower

7.1.1 Tower positioning and displacement

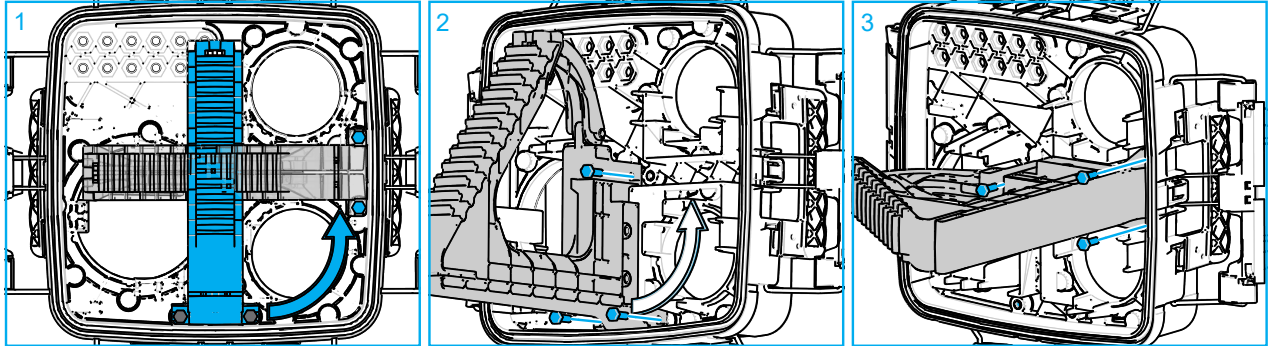

- 1 The tray tower is factory installed in one of two orientations depending on part number configuration. The tray tower orientation can be changed to align with the gel block ports being utilized. The tray tower should be installed between the two utilized ports for easier fiber routing.
- 2 To change the tray tower orientation, remove the 3 bolts holding the tower in place. Move the tower to the position between the two utilized ports.
- 3 Secure the tower with the 3 bolts.

7.1.2 Open tower

The tower has a closed construction. It is possible to open it to facilitate guiding fibers under the tower.

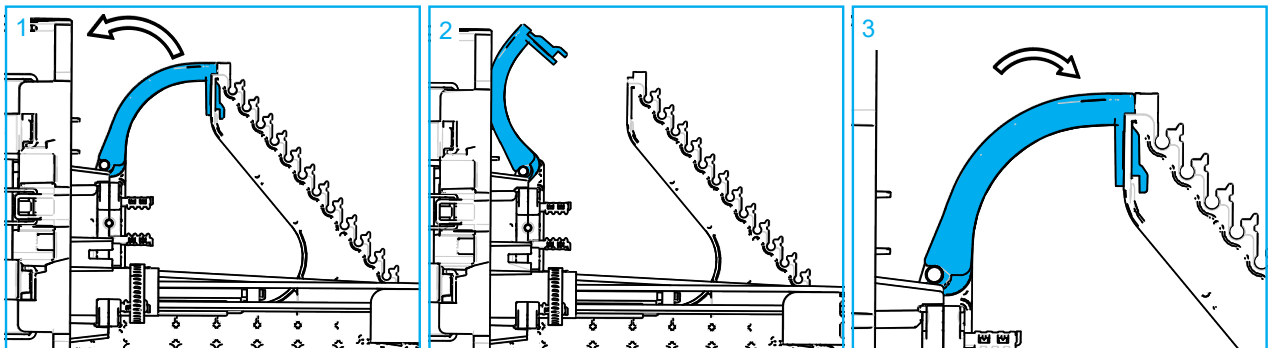

7.2 Cable attachments assembly

7.2.1 Overview

There are 3 cable attachment assemblies available.

- 2 cable attachment assemblies for use with the small gel block ports (3 or 4 cable attachments)
- 1 cable attachment assembly for use with the large gel block port (4 cable attachments)

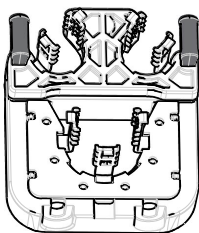

Small 3-Pos.
Cable Attachment

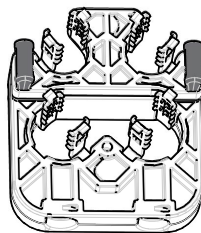

Small 4-Pos.
Cable Attachment

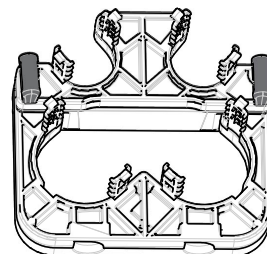

Large 4-Pos.
Cable Attachment

7.2.2 Cable attachment assembly installation

Two cable attachment assemblies can be installed on the tray support tower. To use the full capacity of the closure, a third cable attachment assembly can be installed in the closure with an additional support bracket.

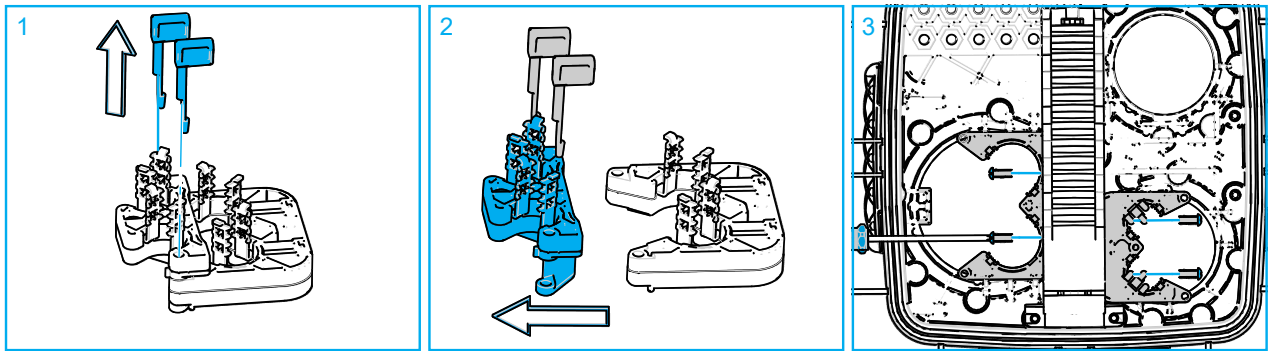

- 1 Remove the two pins that hold the cable attachment assembly in place.
- 2 Remove the top cable attachment assembly.
- 3 Install the bottom cable attachment assembly on the tray support tower with 2 screws.

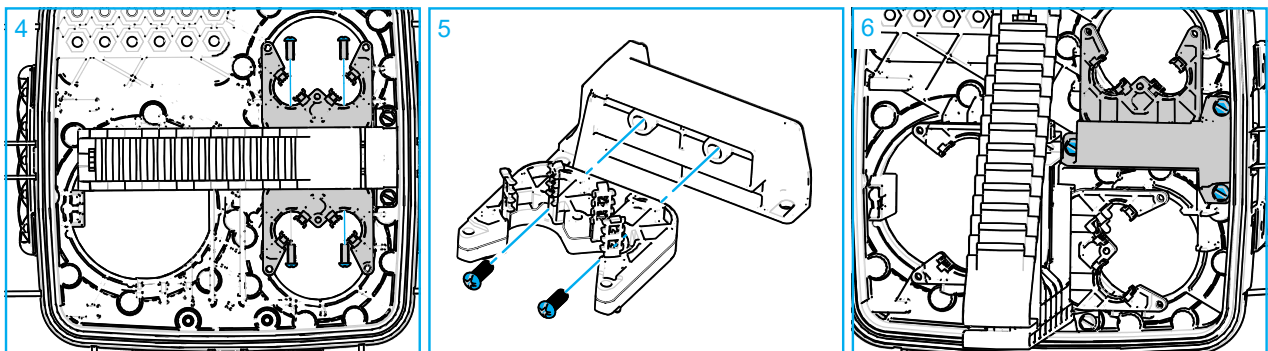

- 4 When the tower is installed between the 2 small ports, install 2 small cable attachment assemblies on the tray support tower.
- 5 If applicable, install a 3rd cable attachment assembly on the additional support bracket.
- 6 Install the support bracket with the cable attachment assembly with 3 bolts between the 2 small gel block ports in the closure.

8 Cable preparation

Cable Type	Opening Location	Min. & Max. Suggested Storage Length	Strength Member lengths		
			Small	Large	XC
Loose Buffer Tube	Stub end and Midspan	300 cm ± 5 cm / 120 ± 2 Inches	31 mm	44 mm	80 mm
Loose Buffer Tube Ribbon			1-1/4 inches	1-3/4 inches	3.2 inches
Central Core Tube Ribbon					

Note: Midspan can be used for up to 1728 fibers, contact technical support for more information.

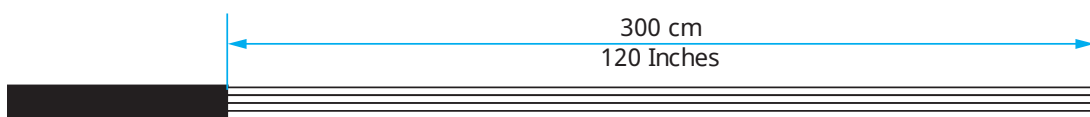

8.1 Remove Jacket



- 1 Remove the cable jacket over a length of 300 cm / 120 Inches.

8.2 Strength member fixation

There are three sizes of strength member attachment brackets and lugs in the kit. Use the large attachment bracket and lug (2) for strength members with diameters over 6,35 mm / 0.25 inches, and the small strength member attachment bracket and lug (1) for smaller strength member. The XC bracket and lug (3) is for use with cable diameter 40 mm / 1.6 inches. The small and large strength member attachment brackets have 3 prongs on one end. The central prong is for use with central strength members. For dual strength members, use the two outer prongs

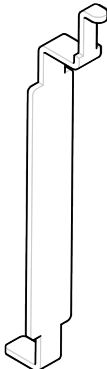
	Small bracket (1)		large bracket (2)		XC-bracket (3)	
	mm	Inches	mm	Inches	mm	Inches
Strength member diameter	< 6,35	< 0.25	> 6,35	> 0.25	Cable Ø 40 mm / 1.6 inches	
Strength member length	31	1-1/4	44	1-3/4	80	3.2
						

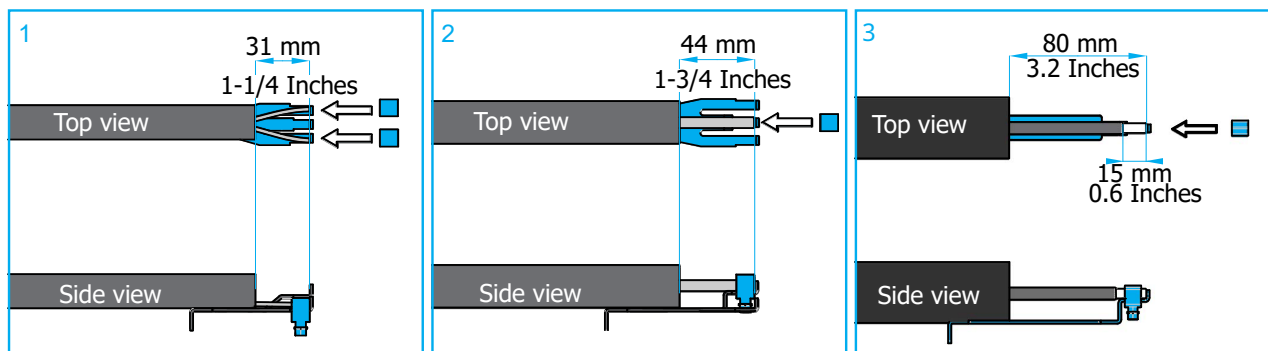

- 1 If using the small strength member attachment bracket (1), trim the strength member to 31 mm / 1-1/4 Inches length from the ring cut and secure the strength member on the bracket with the small lug(s).

 **Note:** If needed, remove the unused prongs of the strength member bracket by using pliers to bend them sharply away from the cable and out of the way.

- 2 If using the larger strength member attachment bracket (2), trim the strength member to 44 mm / 1-3/4 Inches length from the ring cut and secure the strength member on the bracket with the appropriate lug.

 **Note:** If needed, remove the unused prongs of the strength member bracket by using pliers to bend them sharply away from the cable and out of the way.

- 3 If using the extra large strength member attachment bracket (3), trim the strength member to 80 mm / 3.2 Inches length from the ring cut. If the diameter of the strength member is too large for the lug, then remove 15mm / 0.6 inches of sheathing from the end of the strength member. Secure the strength member on the bracket with the appropriate lug.

9 Cable installation

- !** **Important:** Slide the gel seal collar over the cables to be installed. Make sure the cables always go through the gel seal collar before inserting through the port on the base.

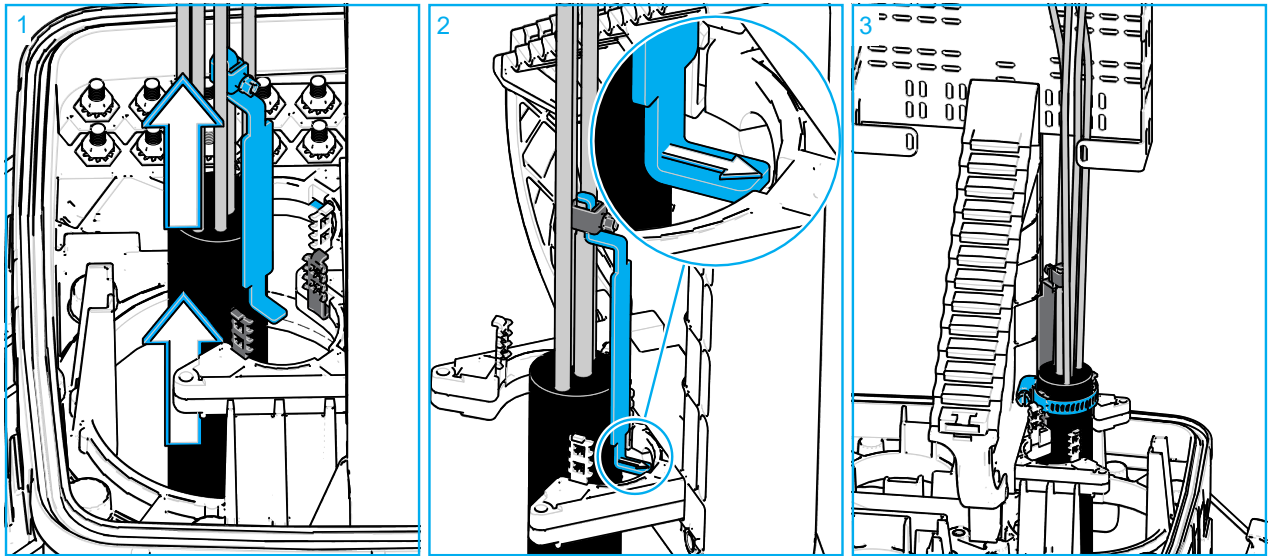
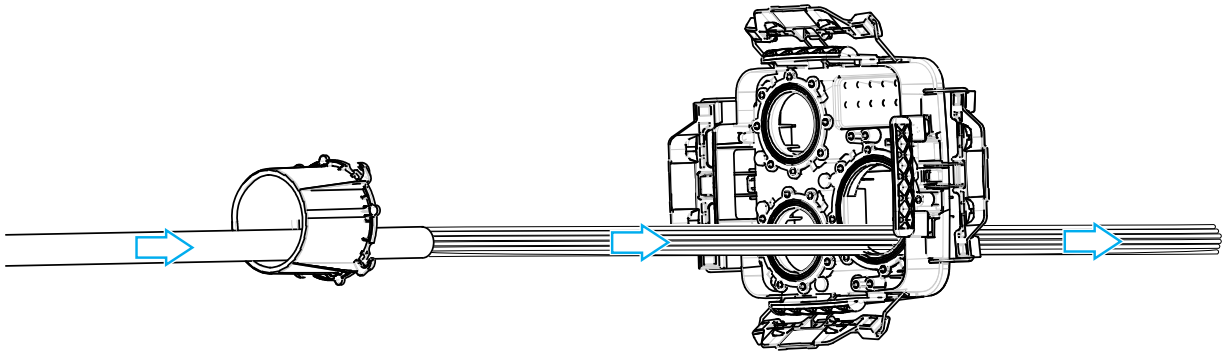

- 1 Insert the cable with the strength member attachment bracket installed through the gel seal collar and into the port on the base.
 - !** **Important:** For armored cables, refer to chapter 15 Grounding [on page 18](#).
 - 2 Install the strength member bracket into the bottom cable attachment assembly by pushing the metal tab into the slot. If an alligator clip is used for grounding, make sure that strength member bracket and grounding attachment are on opposite sides.
 - 3 Adjust the sheath retention clips until they grip the cable sheath. Wrap a hose clamp around the sheath retention clips and cable and use a 1/4-inch nut driver to tighten the hose clamp in place. Tighten the clamp such that the retention teeth fully seat into the cable assembly. Do not over-tighten the clamp.
- Note:** The sheath retention clips should not extend past the ring cut of the cable.
- Note:** Position the hose clamp bolts to the sides of the cable. They could become trapped between the cables and the closure or interfere with upper cable attachments if left on the top or bottom.
- Note:** For cable with no rigid strength member, the strength member attachment is not required.

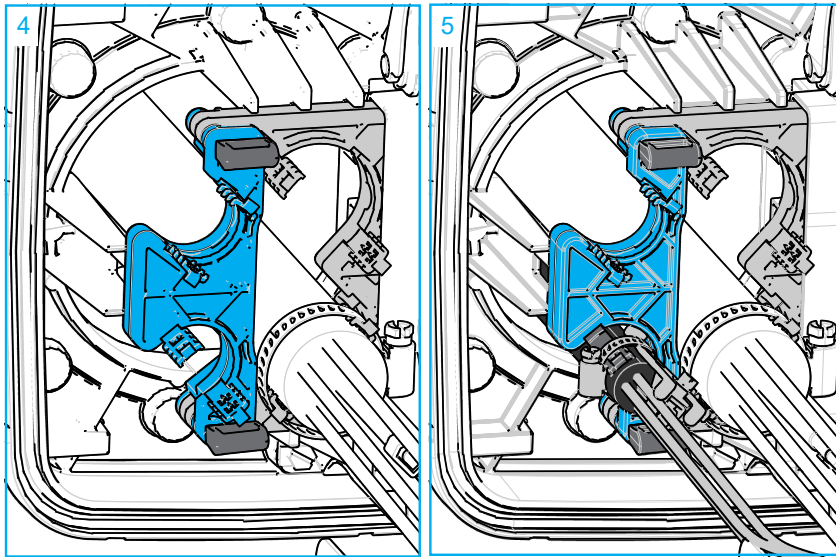

- 4 Re-install "top" cable attachment assembly onto "bottom" cable attachment assembly and secure in place with the two pins.
- 5 If required, cables can be installed in the "top" cable attachment assembly.

10 Routing

10.1 Preparation

 **Note:** Below is an example of cable preparation using a mesh tubing kit (ordered separately). Other prescribed practices may be available per local practice.

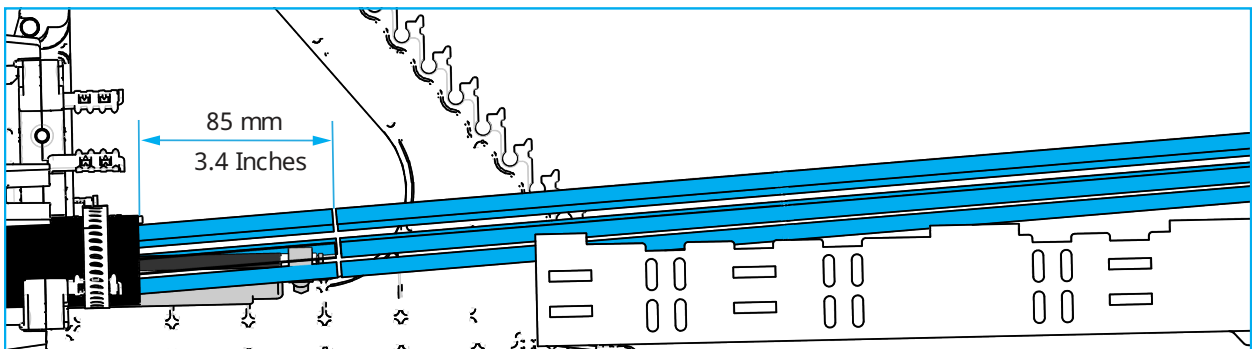

- 1 Ring cut buffer tubes at 85 mm / 3.4 Inches from cable sheath ring cut.



- 2 Slide a piece of the big mesh tube (Length: 100 cm / 40 inches - Diameter: 31.75 mm / 1.25 inches) over the entire group of buffer tubes and a small mesh tube (Diameter: 9,53 mm / 3/8 inch) with a length of 86 cm / 34 inches over each buffer tube.

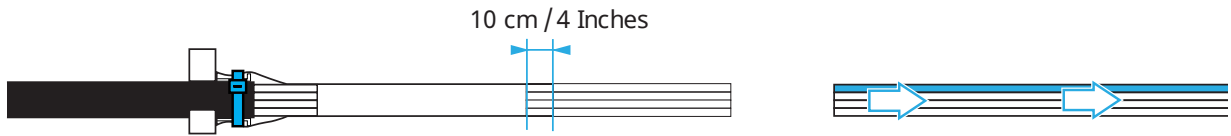

- 3 Slide back the loose buffer tubes and slide the big mesh tube toward the ring cut to, just above the cable clamp point. Secure with a cable tie. Slide the small mesh tubes into the big mesh tube with an overlap of 10 cm / 4 Inches.

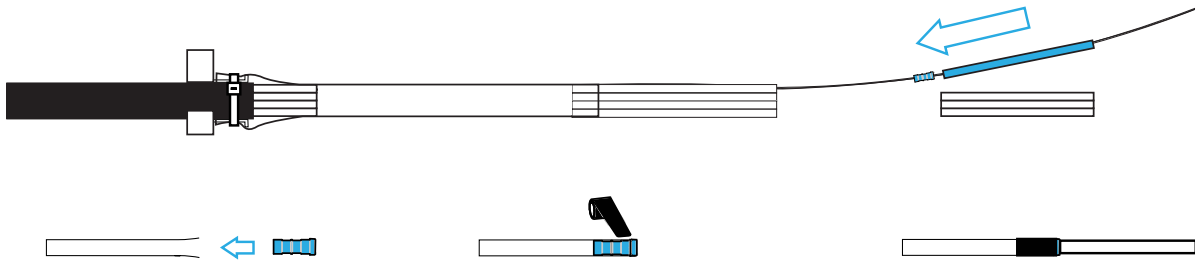

- 4 Remove each loose buffer tube and slide a fiber sleeve and a small section of the buffer tube (20 cm / 8 inches) back over the fibers for color identification. Slide the fiber sleeve into the small mesh tube and secure with 1 wrap of tape.

Note: Finish the tubes one by one making sure tubing colors are kept in order.

- 5 Repeat for all tubes.

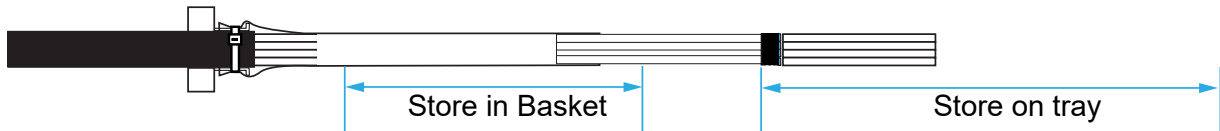

- 6 The transition of the big mesh tube to the small mesh tube will be stored in the basket.

10.2 Route in basket

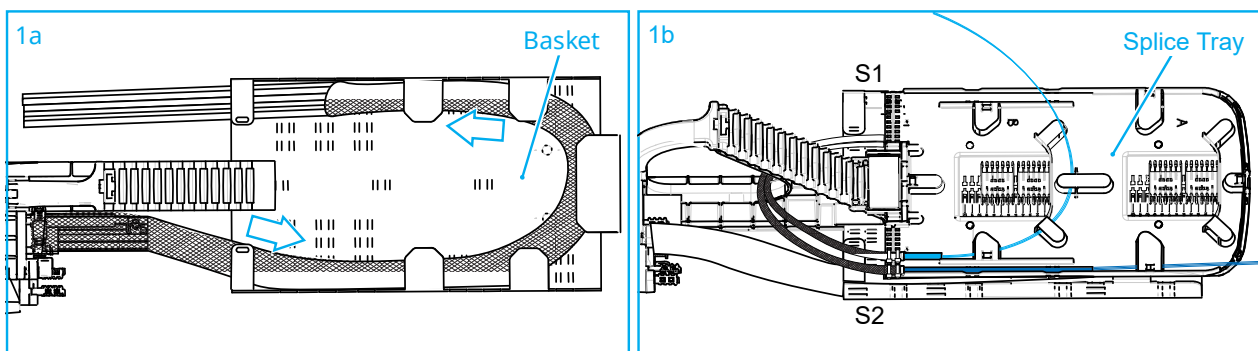

- 1
 - a When routing two cables into the same side of the closure, route the first cable into one side of the basket and around to the opposite side.
 - b Then route the tubes/fibers out of the basket, going underneath the tray tower and up to the splice tray area on the S2 side (same side as cable entry).

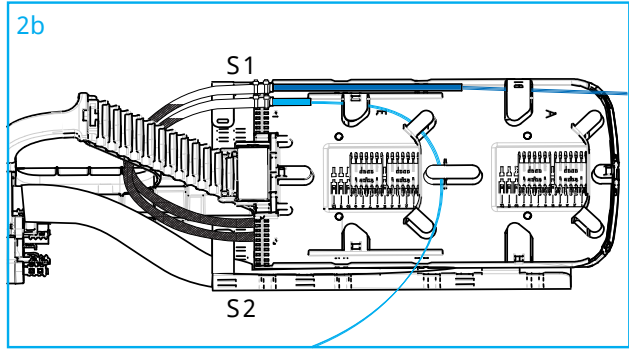
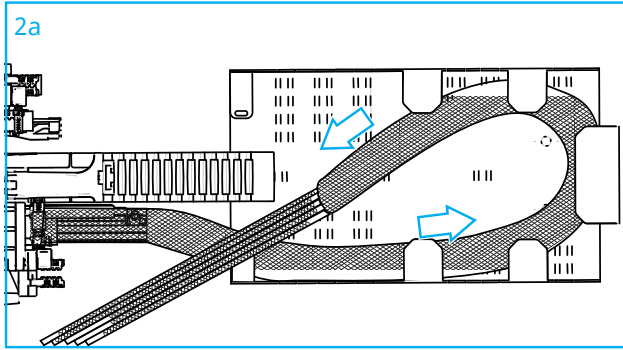

2

- a Route the second cable into the same side of the basket and make an S-turn in the basket.
- b Then route the tubes/fibers out of the basket, going underneath the tray tower and up to the splice tray area on the S1 side (opposite side of cable entry).

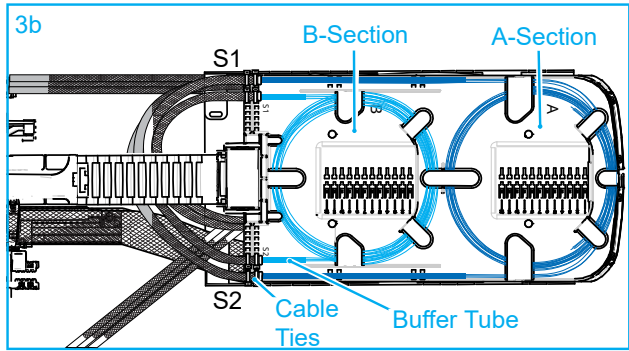
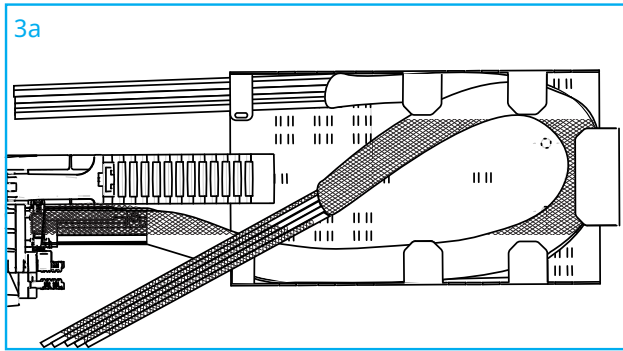

- 3 At the entrance to the splice tray, secure the end of the mesh tubing with the fiber sleeve underneath to the tray with 2 cable ties.

Note: Make sure the transition between the big and small mesh tubes is in the basket.

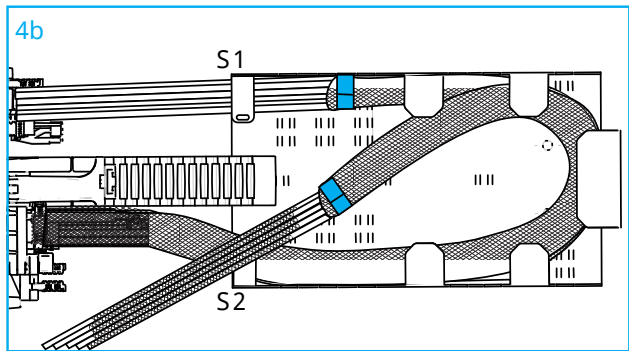
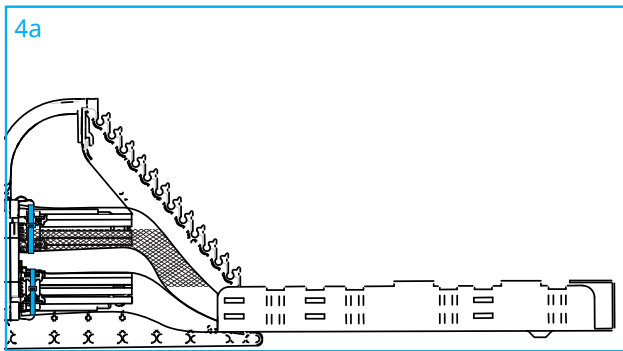



- 4 When all tubes are routed, ensure the big mesh is secured with a cable tie over the sheath retention clips and secure the transition of the big and small mesh tubing in the basket with Velcro.

11 Trays

11.1 General product information

FOSC 650 supports up to twelve hinged splice trays dependent on type. Capacity per tray is dependent upon the style of tray. FOSC 650 splice trays have a maximum capacity of 576 ribbon fibers. This capacity is achieved by using 4 splice modules per tray. Each module has 6 splice positions and each position holds up to 2 ribbon sleeves.

 **Note:** FOSC D size trays can be installed into the FOSC 650 as well. Refer to the FOSC D tray installation manual for more information.

 **Note:** For flat matrix ribbon store fiber slack in basket or use FOSC D double height tray to store slack in tray.

11.2 Tray dimensions

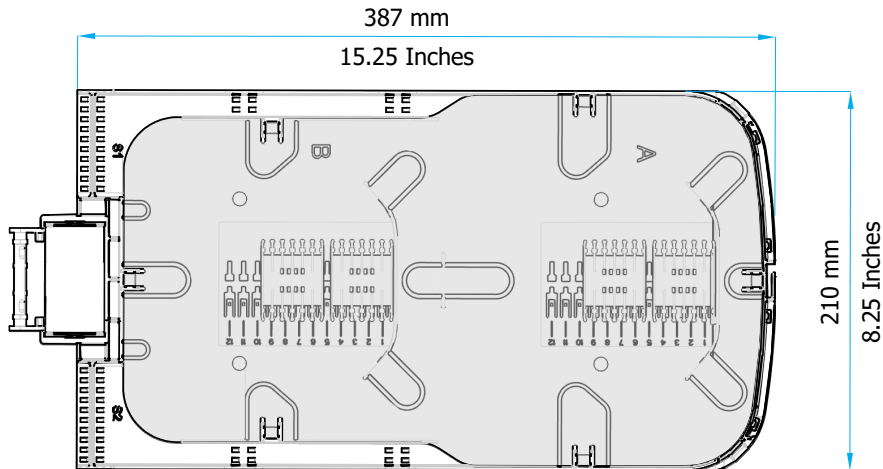

11.3 Tray installation

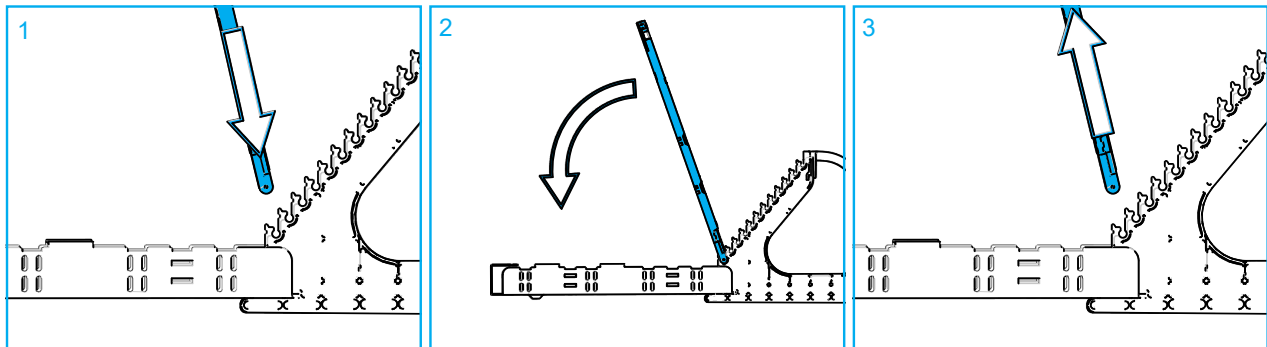

- 1 Hold the tray vertically over the tray holder bracket.
- 2 Insert the tray hinge into the first slot on the tray holder bracket and lower the tray. Repeat this procedure to add the other trays.
- 3 To remove splice trays from the closure base, raise the tray. Pull the tray hinge out of the tray holder bracket, releasing the tray.

11.4 Tray support

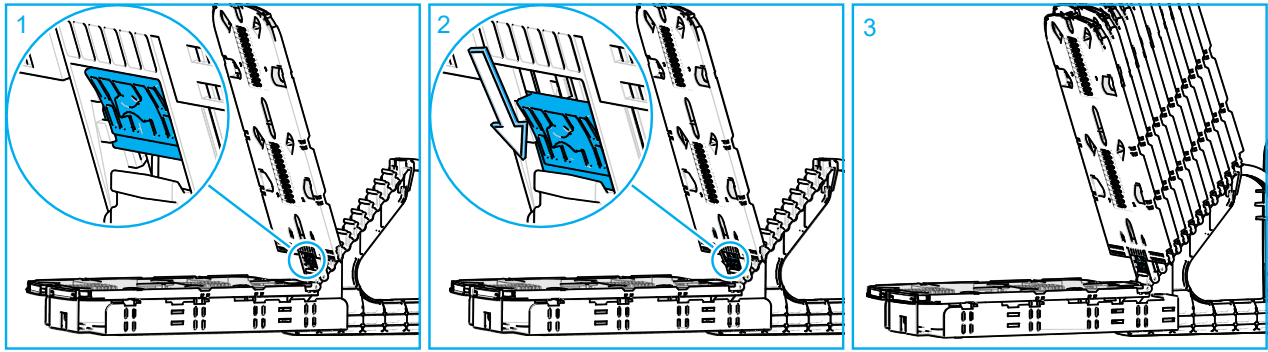

- 1 The tray includes a tray support latch to lock the tray in a raised position.
- 2 Lift the tray and lock it in position by sliding down the tray support latch. To unlock the tray, slide the tray support latch up and lower the tray.
- 3 To regain access to a lower tray, all trays above it must be individually locked in the open position. Start by locking the top tray, then lock the lower ones until the lower tray is reached.

11.5 Route on tray

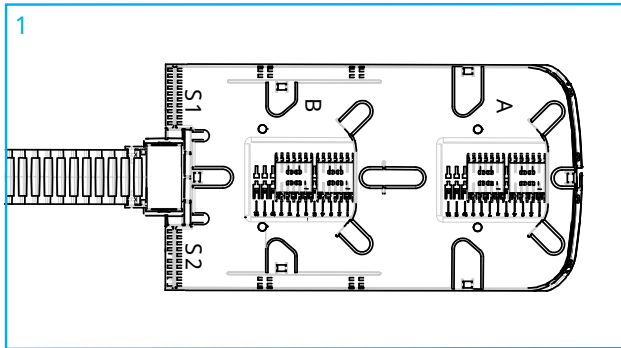

- 1 The tray has 2 splice zones, A and B. Left side (S1) is typically for the drop fibers. Right side (S2) is typically for the feeder fibers.

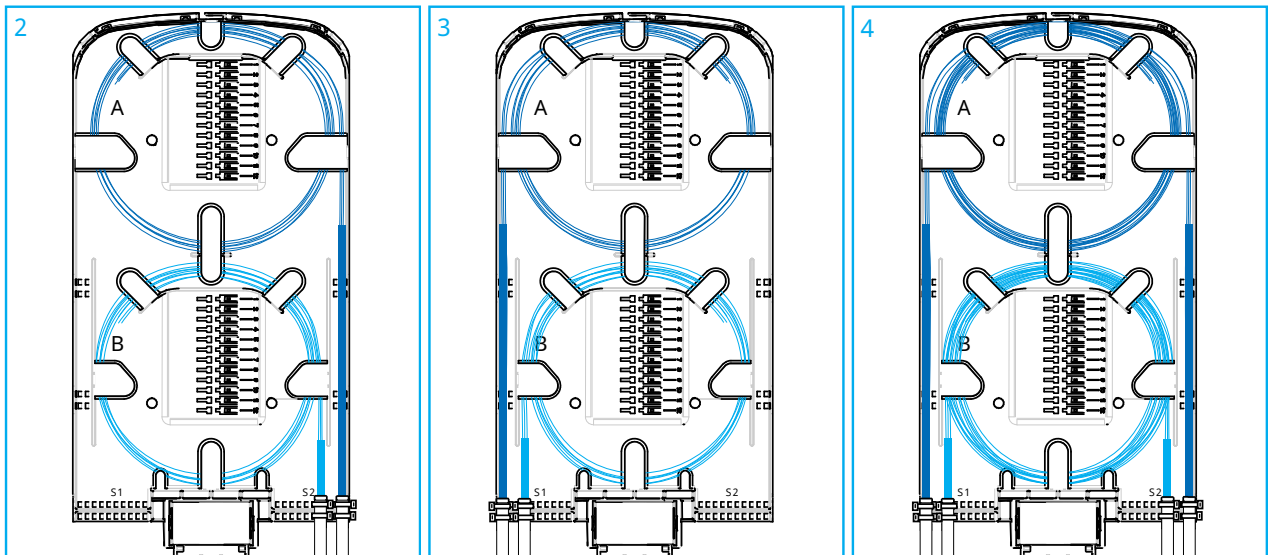

- 2 Route the small braided tubes from the feeder cable through the basket to the S2 side of the tray. Secure the braided tube to the tray with the fiber sleeve and 2 cable ties. Slide the colored tube against the fiber sleeve. Adjust the length of the colored buffer tube going to the B section of the tray to 4 cm / 1.6 inches. Store the fibers in sections A and B.

- 3 Route the small braided tubes from the drop cable through the basket to the S2 side of the tray. Secure the braided tube to the tray with the fiber sleeve and 2 cable ties. Slide the colored tube against the fiber sleeve. Adjust the length of the colored buffer tube going to the B section of the tray to 4 cm / 1.6 inches. Store the fibers in the sections A and B.
- 4 Picture 4 shows the feeder and drop fibers stored and ready for splicing.

11.6 Splice Fibers and Store on Trays

Fiber splicing should be done in compliance with company approved practices. This section outlines some basic splice organizing techniques to be followed.

- 1 Always begin splicing with the bottom tray. Lift the remaining trays and secure all of them with the tray support latch.
- 2 Remove all stored and unspliced fibers from the tray and clean those that will be spliced. Refer to the splice manufacturer's instructions for directions on fiber splicing.
- 3 Store the first completed splice in the top splice slot (the slot farthest from the hinge). Coil the slack loops around the respective tray sections (A or B) in an orderly fashion. The splice modules can be moved or removed to accommodate most splice arrangements.

 **Note:** Make sure all fibers are routed under the tray fingers.

- 4 When all the splices in the tray are stored, replace the clear plastic tray cover.

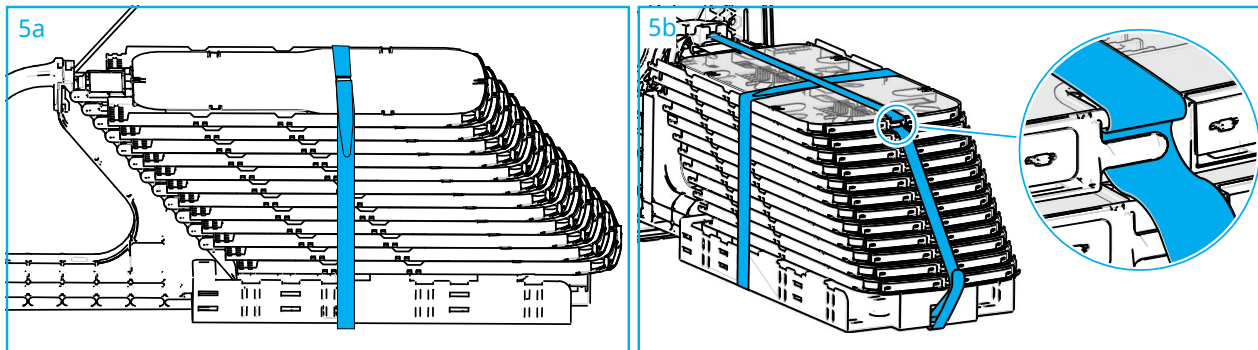

- 5 Secure all trays to the basket with the fastener straps.

12 Gel blocks

Small gel blocks

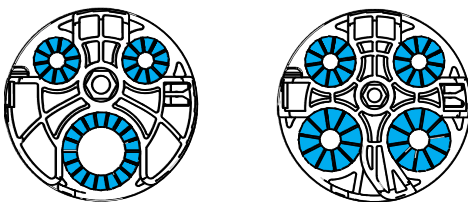

Large gel block

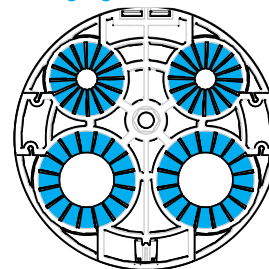

12.1 Install gel blocks

Small 4-way gel block

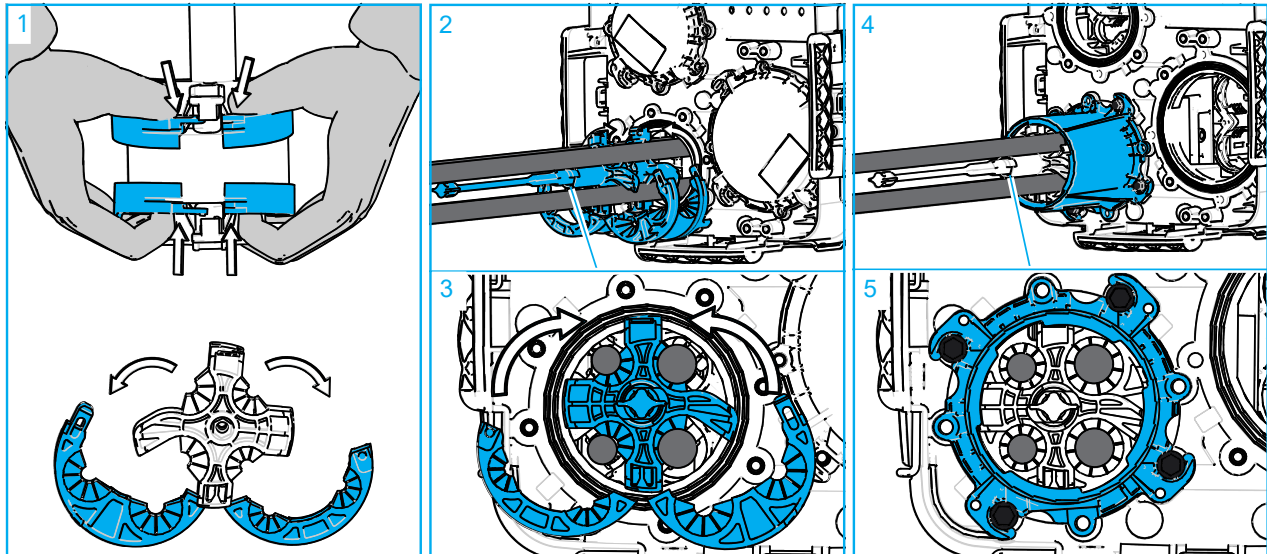

Large 4-way gel block

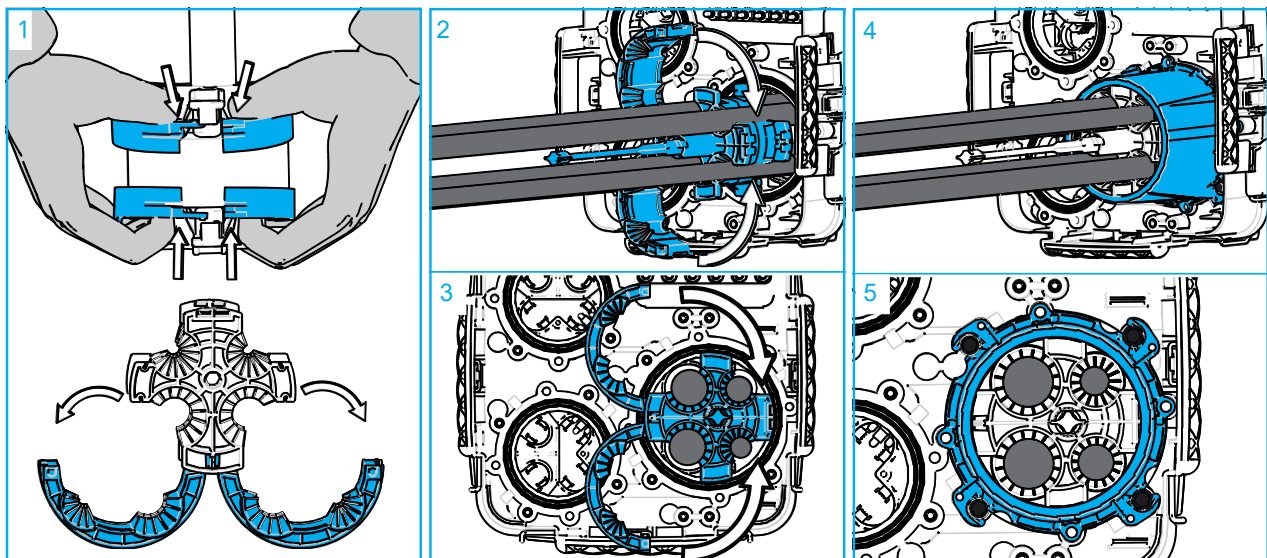

- 1 Unlock and open the gel block assembly.
- 2 Place the gel block assembly between the cables with the tail centered.
- 3 Close and lock the assembly.
- 4 Place the gel block collar bolts into their base mounting positions prior to installing each gel block collar. Leave room for collar eyelets to rotate under each bolt head. Slide the gel block collar into position by pressing collar onto base and rotating counter clockwise until eyelet wall is firmly against the collar bolts.
- 5 Hand tighten all bolts. If using a torque wrench do not exceed 25 in. lbs. All bolts must be seated in the center of their corresponding eyelet.

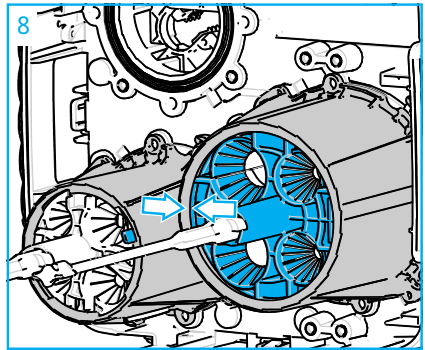
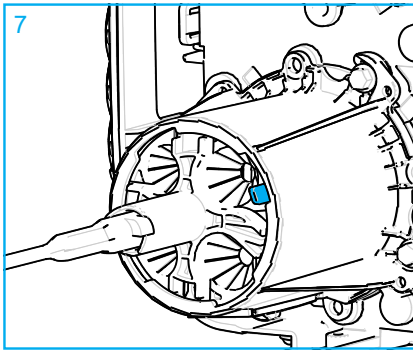
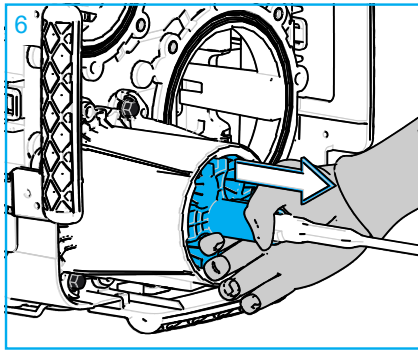

- 6 Pull the gel block into position.
- 7 The small gel blocks are in place when the gel block tab pops out.
- 8 The large gel block is in place when it touches the end of the gel seal collar.

 **Note:** The external bracket needs to be installed to secure the large gel block cables. See chapter 16 External cable fixation [on page 19](#) for the installation steps.

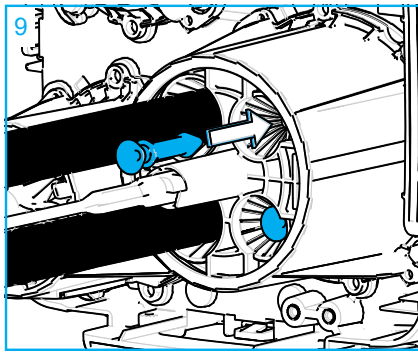

- 9 Insert one cable port plug into each empty cable port.

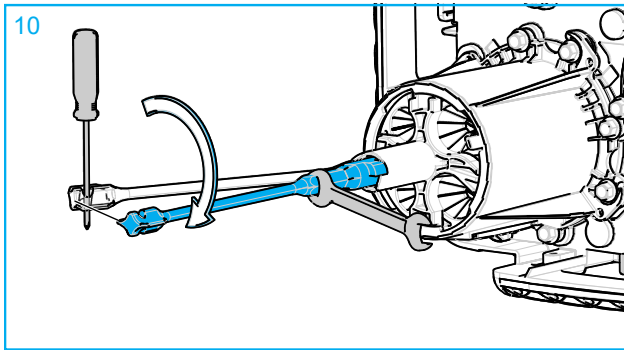

- 10 Twist the "tail" of each gel block clockwise to seal cables (The tail can bend away from cables). When the tail reaches its physical stop, the seal is complete. Insert a screwdriver through the loop in the tail, or use a Crescent wrench to apply extra torque, if required.

 **Note:** Do not over-tighten or use a drill to turn the tail as this could cause damage to the gel seal.

13 Close the closure

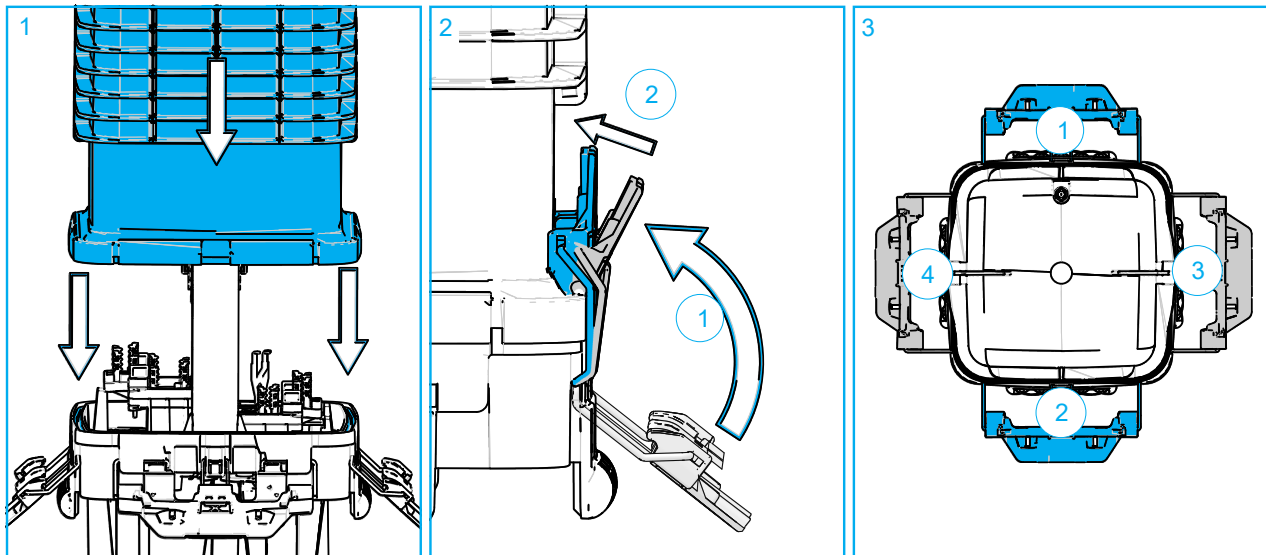

- 1 Make sure that the rubber gasket in the base of the closure is clean and seated in the groove. Slide the dome over the fiber management system and back onto the base.
- 2 Lift the latch and place the hook over the rim of the dome. Close the latch.
- 3 Close the 4 latches crosswise 2 by 2. First at the back and front, then left and right. This will ensure an even pressure distribution on the sealing ring.

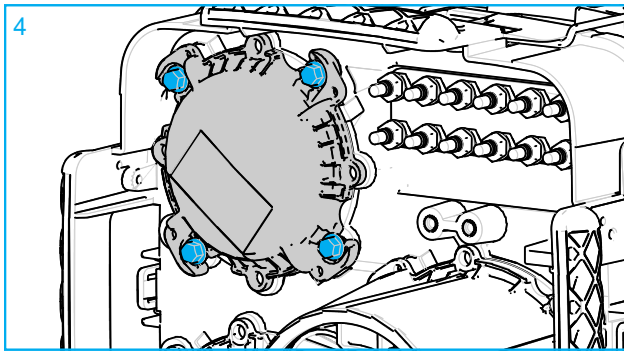

- 4 Install a cover on unused gel block ports.

14 Testing the Closure Seal

Pressure test the closure with no more than 5 psi. Thoroughly soap all seals and the valve to check for seal integrity.

 **Note:** After flash testing, release the pressure from the closure through the valve.

15 Grounding

 **Note:** Follow local practice for bonding and grounding procedures.

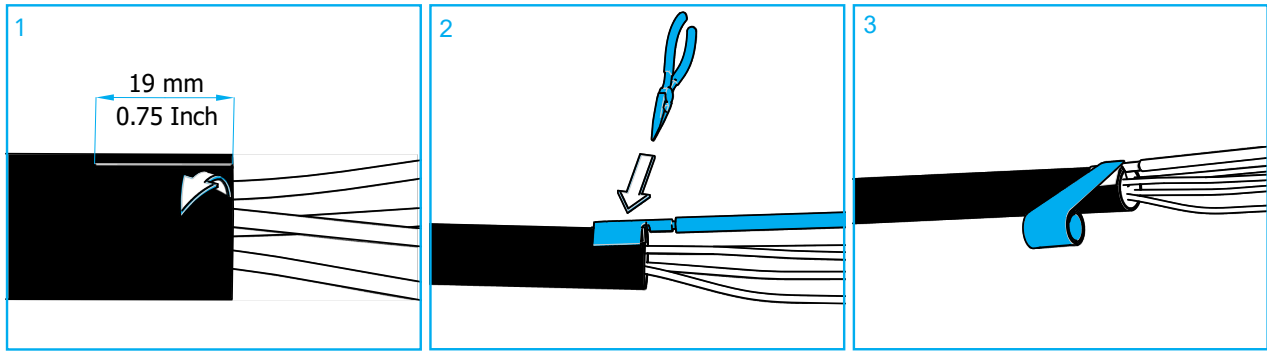

- 1 If a shield is present in the cable, tab the cable 19 mm / $\frac{3}{4}$ inch from the sheath ring cut.
- 2 Attach a supplied bond wire to the tab with the alligator clamp over the sheath and armor. Crimp the alligator clamp onto the sheath and armor with a pliers.
- 3 Tape the bonding wire in place and proceed cable installation as explained in the basic installation instructions.

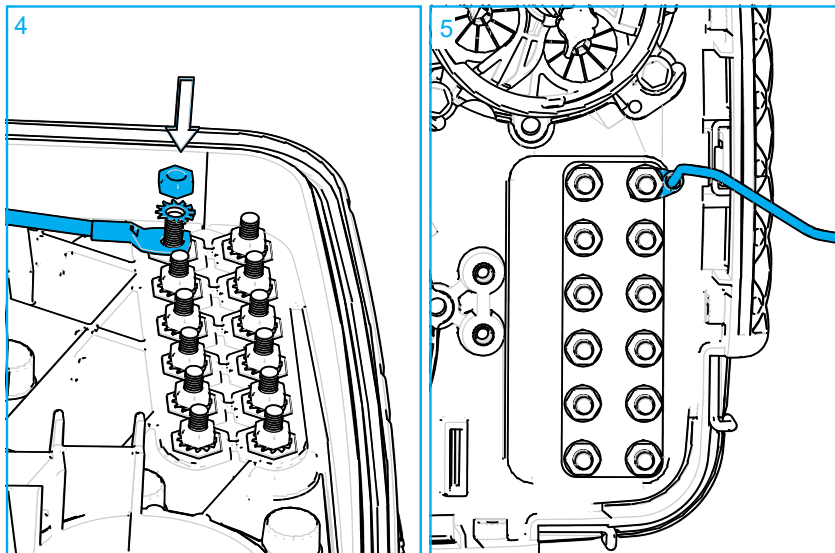

- 4 After installation of the cable in the closure, attach the grounding wire to the ground feed through lug inside the closure. Tighten the nut with a socket wrench up to 40 lb-in of torque.

 **Note:** If isolated grounding is required, the common ground plate can be removed on the outside of the closure.

- 5 The external grounding needs to be attached at the outside of the closure. (External grounding cable is not included in the kit.)

16 External cable fixation

 **Note:** The external cable fixation bracket is only needed when installing cables into the large ports on the large gel block.

16.1 External cable fixation kit content

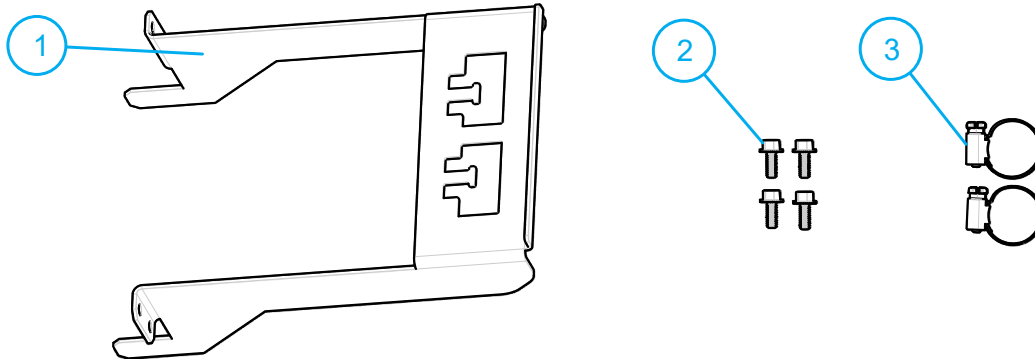

N°	Description	Qty
1	External cable fixation bracket	1
2	Screws	4
3	Hose clamps	2

16.2 Installation external cable fixation bracket

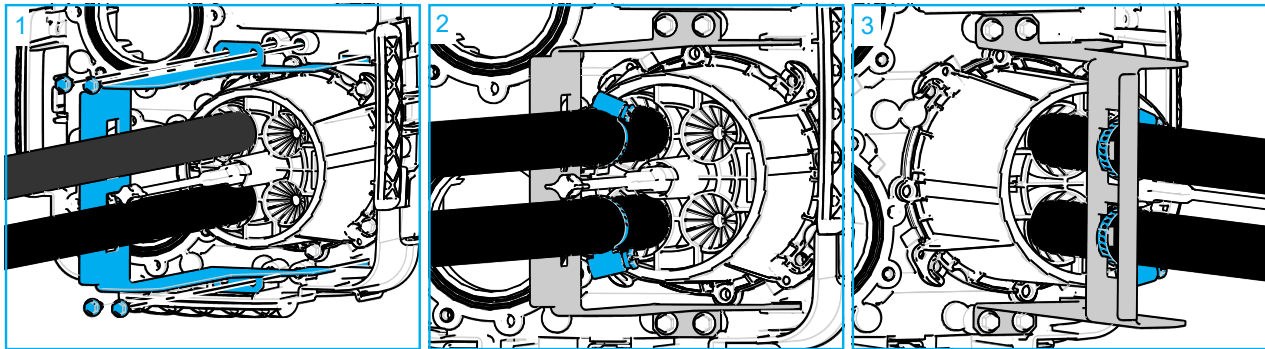

- 1 Install the external cable fixation bracket on the base with the 4 screws.
- 2 Secure the cable to the bracket with the hose clamp.
- 3 Position hose clamps so as to not interfere with future cables.

17 Mount the closure

17.1 Wall mounting

17.1.1 Wall mounting kit

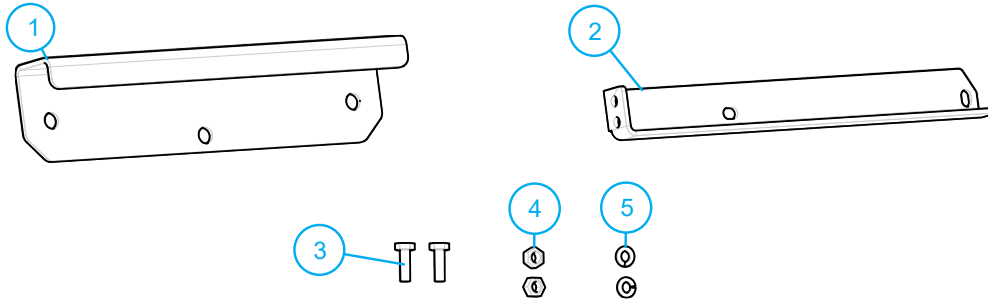

N°	Description	Qty
1	Base wall plate	1
2	Top mounting plate	1
3	Bolts	2
4	Nuts	2
5	Washers	2

 **Note:** Mounting hardware (such as screws, plugs, washers) should be selected according to intended mounting surface (not included in the kit).

17.1.2 Install Mounting bracket

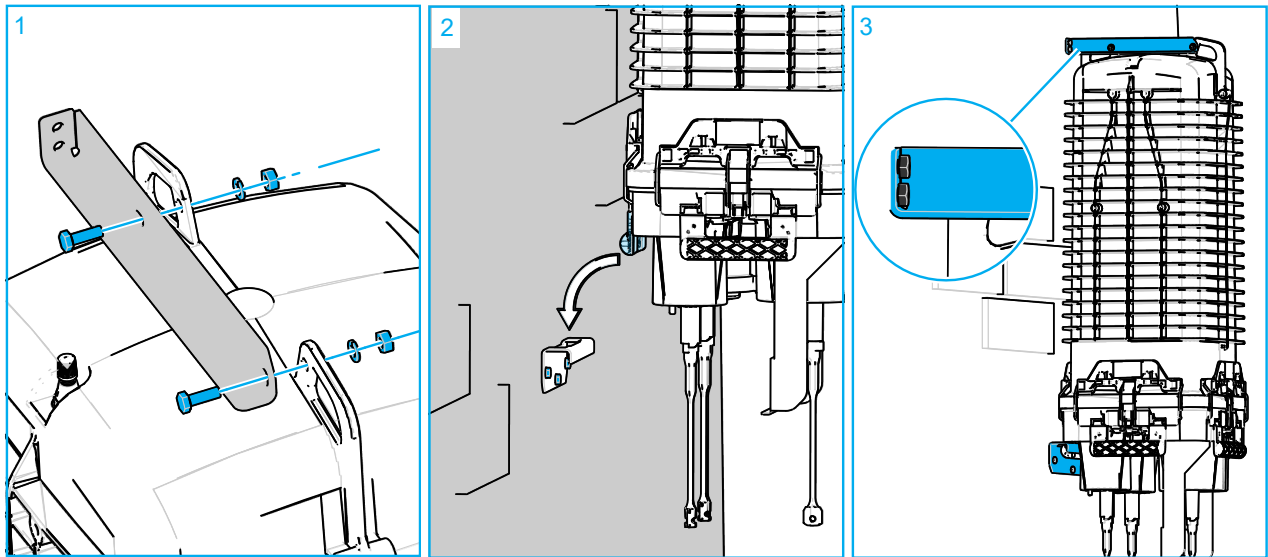

- 1 Mount the top mounting plate on the top of the dome.
- 2 Mount the base mounting plate to a wall and insert the handle of the dome closure into the base mounting plate.
- 3 Secure the top base plate to the wall.

17.2 Aerial mounting

17.2.1 Aerial mounting kit

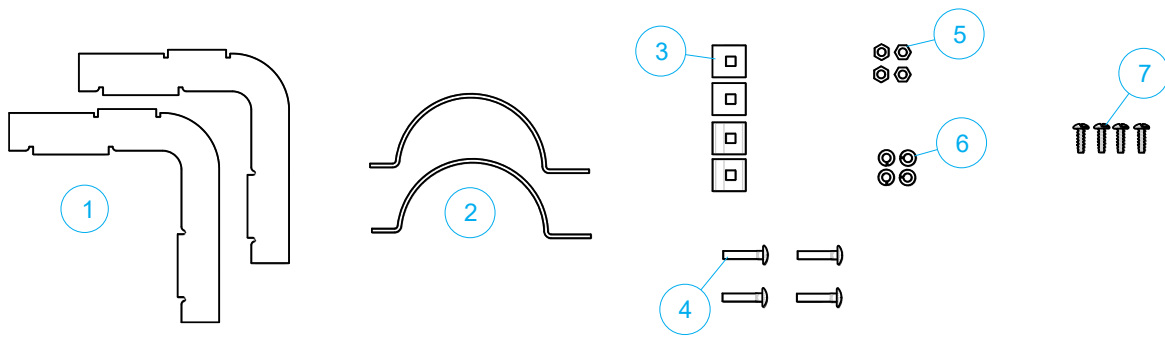

N°	Description	Qty
1	Mobra base plate	2
2	Strand Hanger	2
3	Strand clamp	2
4	Bolts	4
5	Nuts	4
6	Washers	4
7	Screws	4

17.2.2 Install Aerial mounting kit

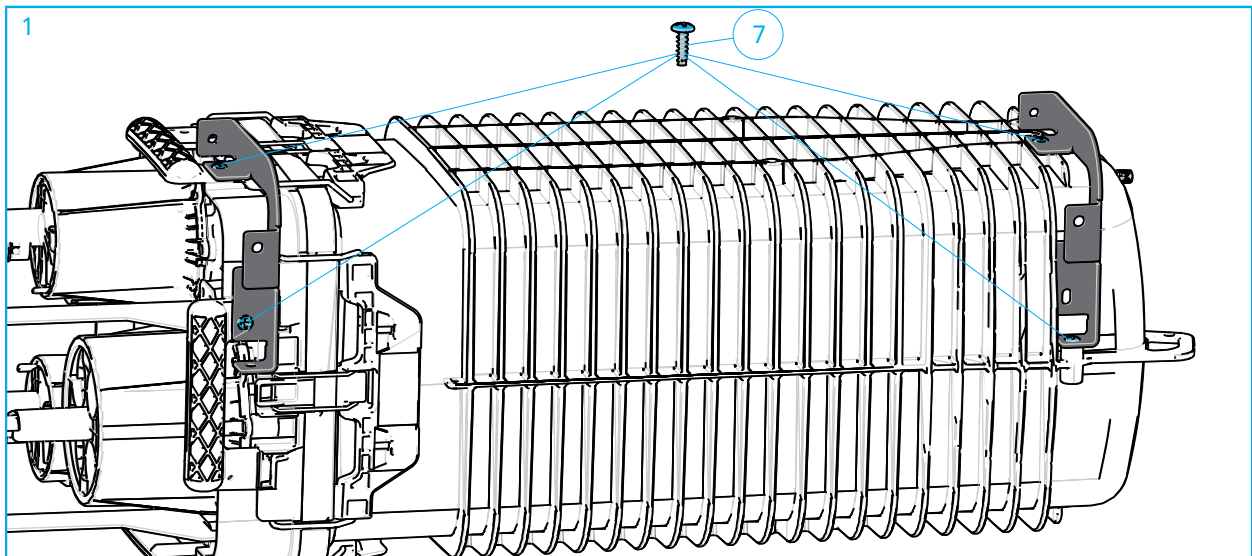

- 1 Install one mobra base plate to the base of the closure with 2 screws. Install the other mobra base plate on the dome of the closure with 2 screws.

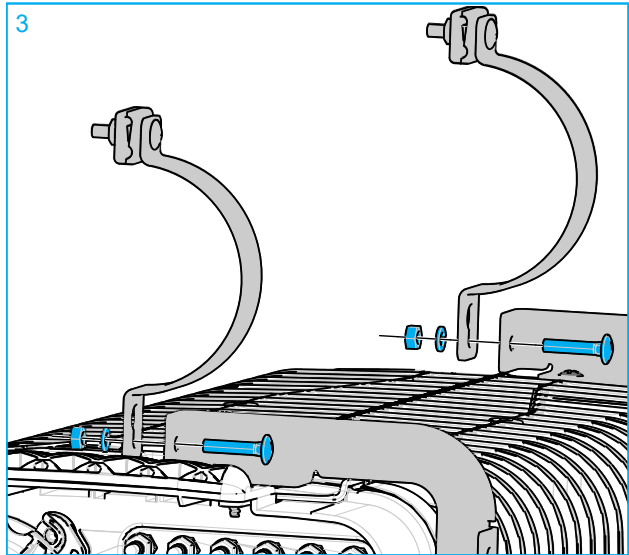
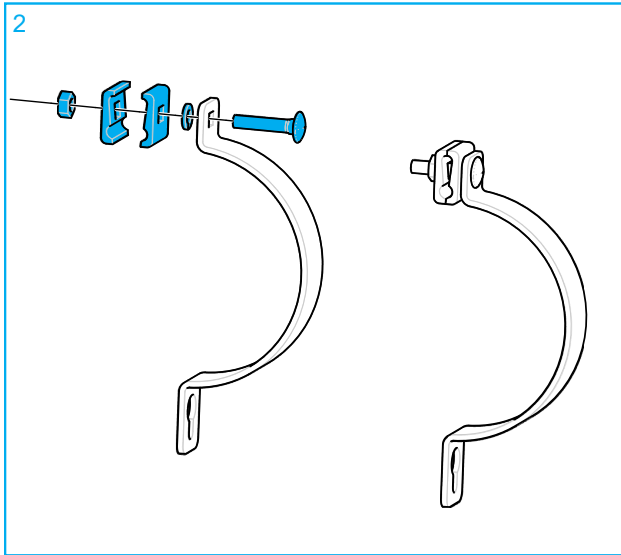

- 2 Attach the strand clamps to the strand hangers.
- 3 Install the strand hangers on the mobra base plates.

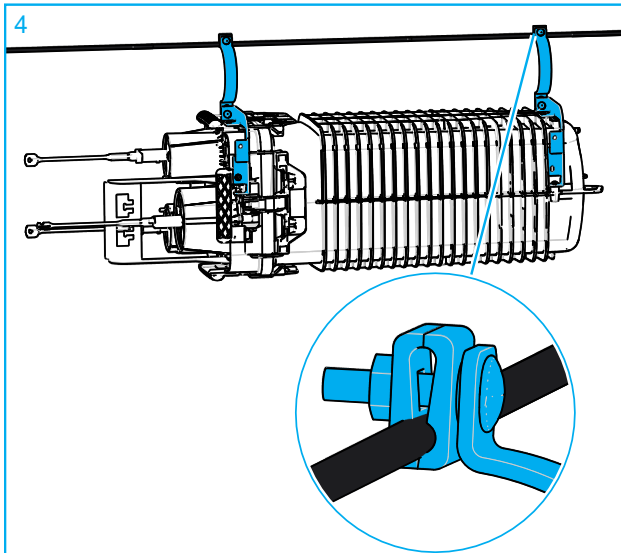

- 4 Secure the closure with the strand clamp on the cable by tightening the clamps with the bolts.

18 Disclaimer

All trademarks identified by ® are registered trademarks in the US and may be registered in other countries. All third party product names, trademarks and registered trademarks are property of their respective owners.

This product may be covered by one or more U.S. patents or their foreign equivalents. For patents, see www.cs-pat.com.

This document is not intended to modify or supplement any specifications or warranties relating to CommScope products or services.

19 Contact information

Visit our website or contact your local CommScope representative for more information. www.commscope.com

For technical assistance, customer service, or to report any missing/damaged parts, visit us at:
<http://www.commscope.com/SupportCenter>