

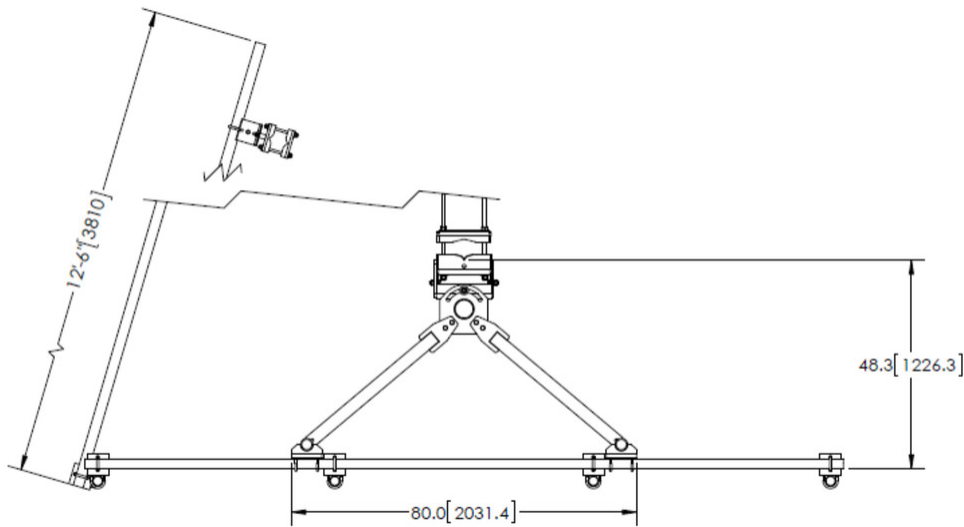

# SFG23-10-3-126

## Outline Drawing



## Material Specifications

**Material Type** Hot dip galvanized steel

## Mechanical Specifications

**Wind Rating** For Specifications, please contact your local ANDREW representative

**Wind Rating Test Method** TIA/EIA-222-G

## Packaging and Weights

**Included** Frame | Pipe mounts | Plain end pipes (3) | Stiff arm | Tower attachment

**Packaging quantity** 1

**Weight, net** 360.152 kg | 794 lb

## Regulatory Compliance/Certifications

Agency	Classification
ISO 9001:2015	Designed, manufactured and/or distributed under this quality management system

## \* Footnotes

**Wind Rating** BWS—Base Wind Speed; FBC—Florida Building Code