

4

3

2

1

- 1.0 GENERAL NOTES
 - 1.1 ALL METRIC DIMENSIONS ARE IN BRACKETS [X. X]
 - 1.2 FOR PATENT INFO: <https://www.cs-pat.com>
- 2.0 DESIGN NOTES
- 3.0 MANUFACTURING/SPECIAL REQUIREMENTS
 - 3.1 TIGHTEN ALL BOLTS SECURING FLAT PLATES BY THE TURN-OF-NUT METHOD. TIGHTEN ALL U-BOLTS USING TURN-OF-NUT METHOD WITH ATTENTION TO LEAVE EQUAL DISTANCE AND EQUAL FORCE ON EACH LEG OF THE U-BOLT.
- 4.0 TEST
- 5.0 PACKAGING
 - 5.1 PACKAGING SHALL MEET COMMSCOPE REQUIREMENTS PER DOCUMENT IS-PL-3005
 - 5.2 PRINTED DOCUMENT TO BE PLACED INSIDE POLYBAG AND THEN IN SHIPPING CONTAINER
 - 5.3 EXTRA HARDWARE MAYBE SUPPLIED, BAGGED AND SHIPPED

REVISIONS			
REV.	DESCRIPTION	DATE	APPROVED
A	INITIAL RELEASE	LS1146 17AUG23	YW1045 40177437CMO

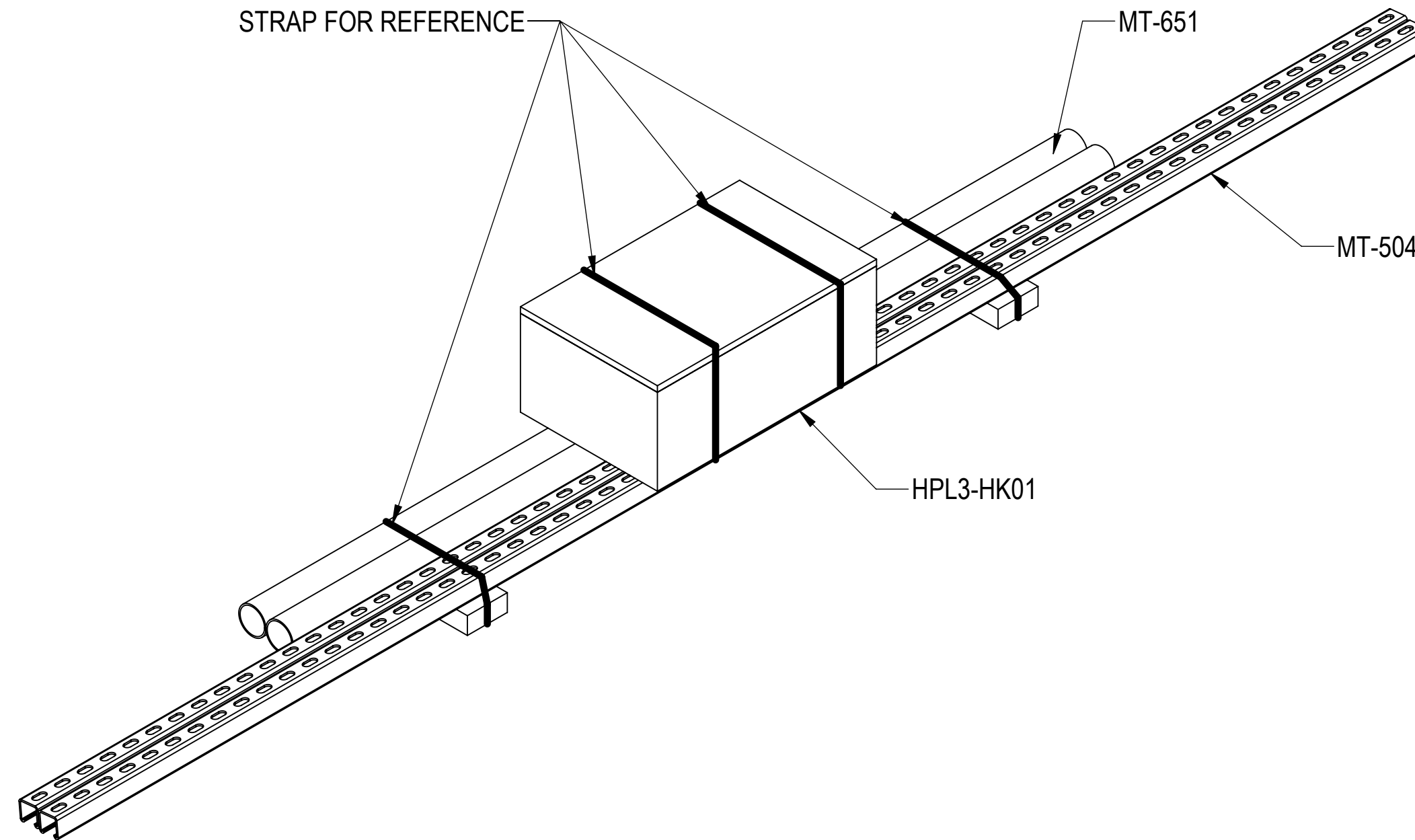

PACKING REQUIREMENT SHOWN FOR US45 MAKE ONLY

COMMSCOPE, INC. OF NORTH CAROLINA																	
TOLERANCES						SAP MATERIAL MASTER											
1 PLACE .X[X] ± 0.2[6.3]			3 PLACE .XXX[X] ± 0.060[1.5]			HPL3											
2 PLACE .XX[X] ± 0.12[3.0]			ANGLES ± 2°			FINISH											
FINISH						MATERIAL											
UNLESS OTHERWISE SPECIFIED DIMENSIONS ARE IN INCHES INTERPRET PER ANSI Y 14.5M-1994	NAME		DATE		TITLE												
	CE LS1146		17AUG23		TELCO-RACK,(2)BASE-SHOE-POST,4-RUNG												
	RW LS1146		08/22/2023														
	AD YW1045		08/28/2023														
	RE YMENG		08/29/2023														
	ECN 40177437CMO					SCALE		DOCUMENT NO.									
					1:12		HPL3										
SIZE		Auth Group		INSL		MODEL			DRAWING			SHEET 1 OF 2					
C						VERSION			STATUS								
		00		IW		A			00			RE			A		

DENSITY		lbs/in ³
MASS	154.09	lbs
VOLUME	550.14	in ³
SURFACE AREA	8268.30	in ²
HEIGHT	77.5"	
LENGTH	8.0"	
WIDTH	120.2"	

4

3

2

1

D

C

B

D

C

B

A

A

4

3

2

1

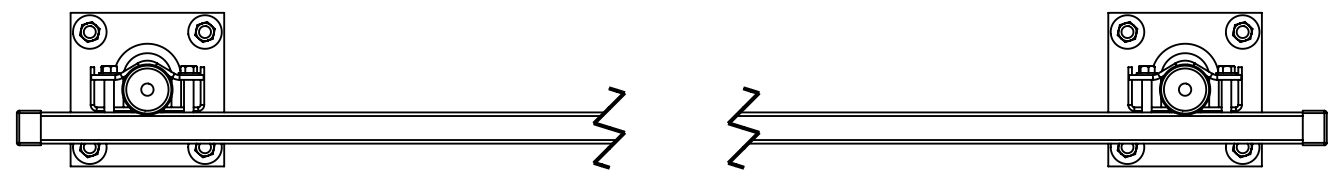
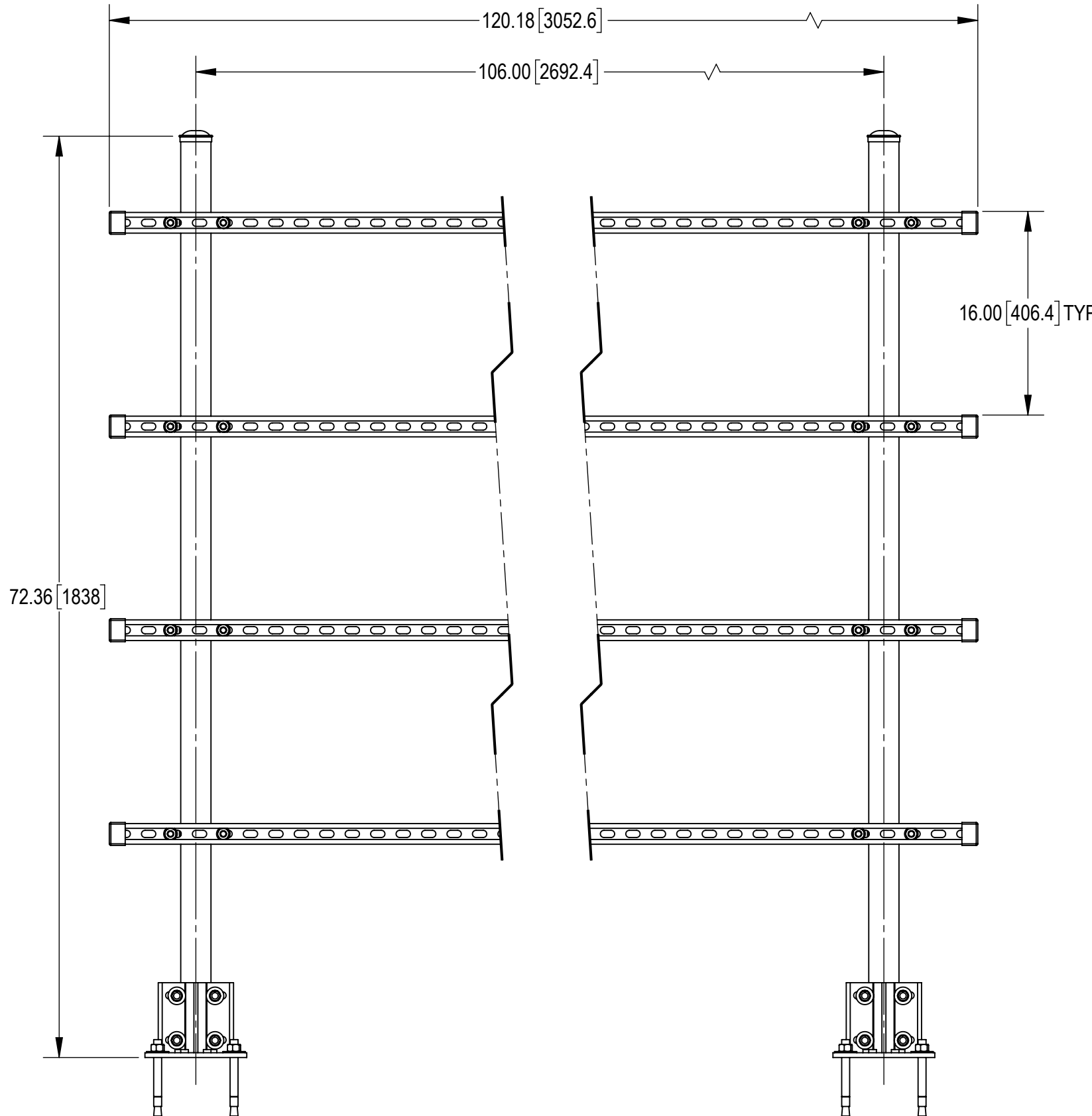
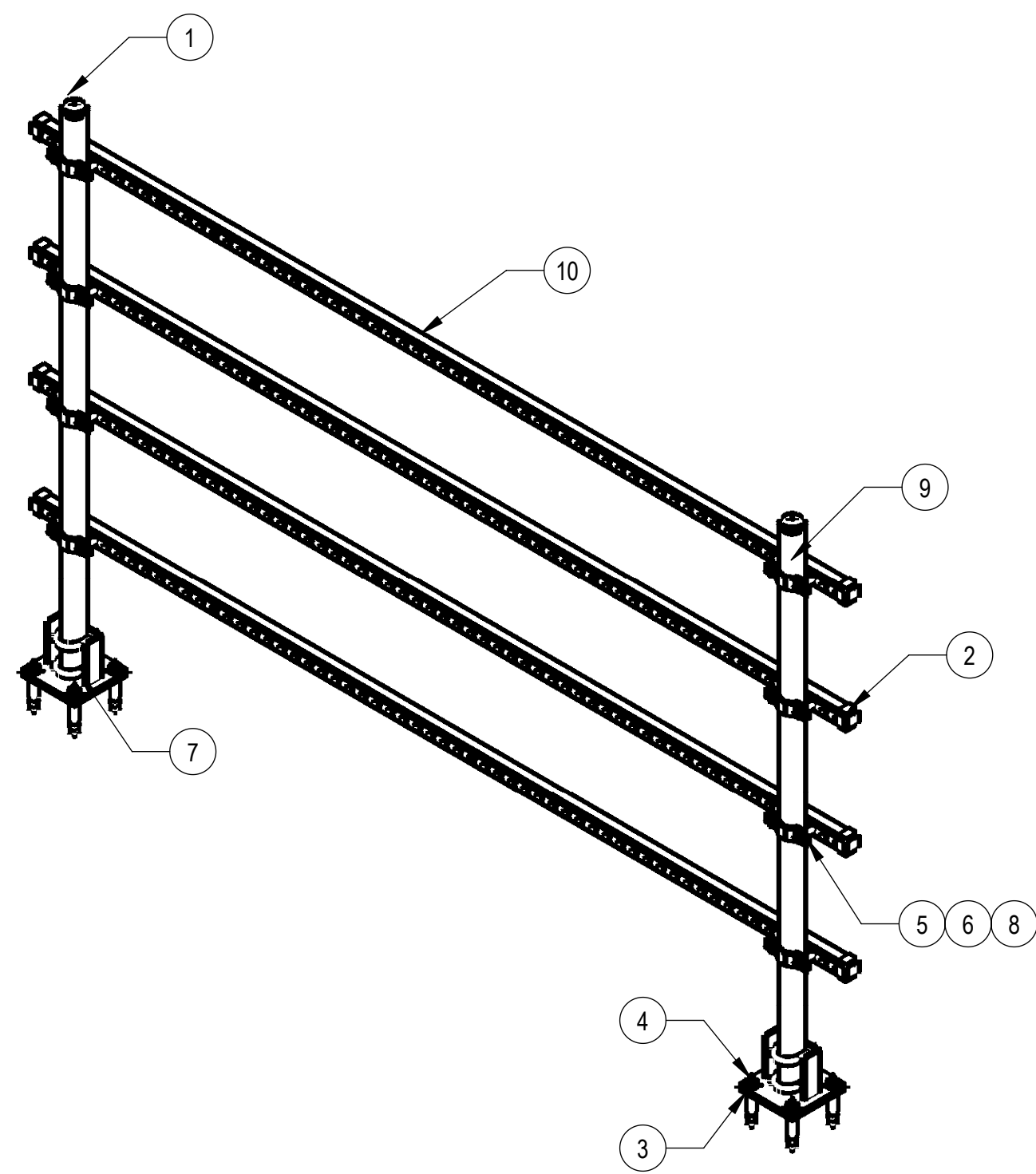

COMPONENT PART NUMBERS PROVIDED FOR ASSEMBLY PURPOSES;
INDIVIDUAL COMPONENTS MAY BE SHIPPED AS PARTS WITHIN AN INCLUDED KIT

ITEM	PART NO.	DESCRIPTION	QTY.	WEIGHT	NOTE NO.
1	PC-238	Ø 2-3/8" PIPE CAP	2	0.14 LBS	
2	PTCR01	END CAP	8	0.05 LBS	
3	WBBS04	WELDMENT, FOOT	2	9.40 LBS	
4	MT-280	5/8" ANCHOR BOLT	8	0.64 LBS	
5	ACP10	1.5" - 3.5" O.D. CLAMP HALF	8	0.61 LBS	
6	GB-04345	1/2" X 3-1/2" GALV BOLT KIT	16	0.24 LBS	
7	GUB-4240	1/2" X 2-1/2" X 4" GALV U-BOLT KIT	4	0.56 LBS	
8	GWF04A	1/2" GALV FLAT WASHER (A325)	32	0.02 LBS	
9	MT-651	2.375"OD X 72" GALV PIPE	2	26 LBS	
10	MT-504	SQUARE SUPPORT RAIL, 12 GA, SLOTTED, 120"	4	20.35 LBS	

COMMSCOPE, INC. OF NORTH CAROLINA				
TITLE TELCO-RACK,(2)BASE-SHOE-POST,4-RUNG				
SIZE C	SCALE 1:10	DOCUMENT NO. HPL3		
DRAWING		VERSION	STATUS	REVISION
		00	RE	A
				SHEET 2 OF 2

© 2023 CommScope, Inc. Confidential

4

3

2

1