

- 1.0 GENERAL NOTES
- 1.1 ALL METRIC DIMENSIONS ARE IN BRACKETS [X.X]
- 1.2 FOR PATENT INFO: <https://www.cs-pat.com>

- 2.0 DESIGN NOTES
- 2.1 ANY HAZARDS OR OBSTRUCTIONS TO THE CLIMBING FACILITY AND SAFETY CLIMB MUST BE IDENTIFIED PRIOR TO INSTALLING THE APPURTENANCE. ADDITIONAL PRODUCTS MAY BE REQUIRED TO MAINTAIN THE INTEGRITY OF THE SAFETY CLIMB. DURING INSTALLATION, TEMPORARY AND/OR PERMANENT PRECAUTIONARY MEASURES SHOULD BE TAKEN TO PRESERVE THE CLIMBING FACILITY AND/OR SAFETY CLIMB.

- 2.2 FITS MONOPOLES 15"-50" O.D.
- 2.3 ANTENNA PIPES SHOULD BE CENTERED AND EVENLY SPACED.
- 2.4 POSITION MOUNT OR ADJUST SAFETY CLIMB CABLE SO NOT TO HINDER OR DAMAGE OR OBSTRUCT THE SAFETY CLIMB. SAFETY CABLE ROUTING BRACKET MAY BE PURCHASED SEPARATELY.
- 2.5 CABLE GUIDE OPTIONAL KITS: SCG-005, SCG-004 AND SCG-001, PLEASE REFER TO DOC SCG SERIES.

- 3.0 MANUFACTURING/SPECIAL REQUIREMENTS
- 3.1 TIGHTEN ALL BOLTS SECURING FLAT PLATES BY THE TURN-OF-NUT METHOD. TIGHTEN ALL U-BOLTS USING TURN-OF-NUT METHOD WITH ATTENTION TO LEAVE EQUAL DISTANCE AND EQUAL FORCE ON EACH LEG OF THE U-BOLT.

- 4.0 TEST
- 5.0 PACKAGING
- 5.1 PACKAGING SHALL MEET COMMSCOPE REQUIREMENTS PER DOCUMENT IS-PL-3005
- 5.2 PRINTED DOCUMENT TO BE PLACED INSIDE POLYBAG AND THEN IN SHIPPING CONTAINER
- 5.3 EXTRA HARDWARE MAYBE SUPPLIED, BAGGED AND SHIPPED

REVISIONS			
REV.	DESCRIPTION	DATE	APPROVED
A	INITIAL RELEASE	LS1146 18SEP23	YW1045 40179365CMO

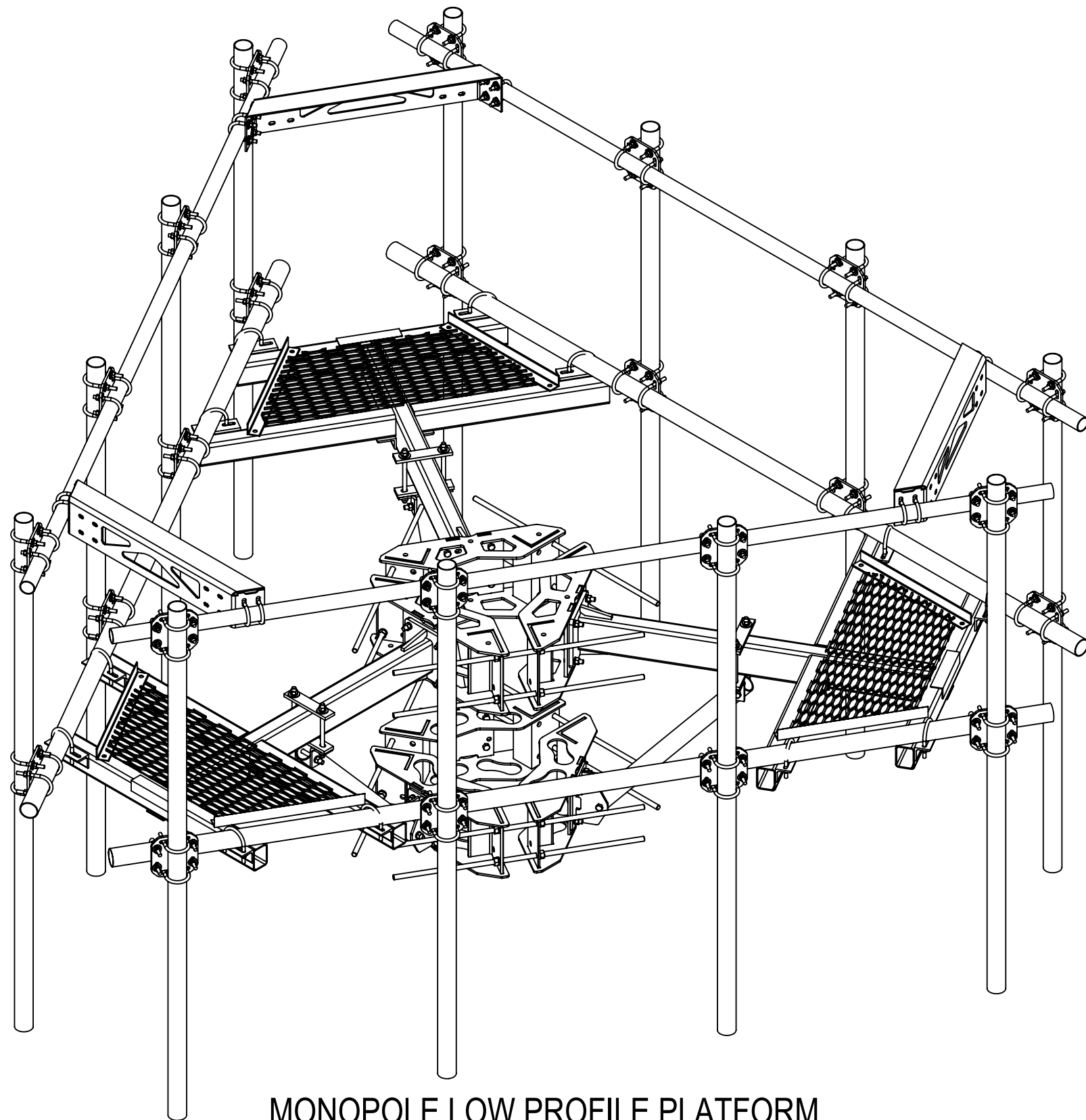
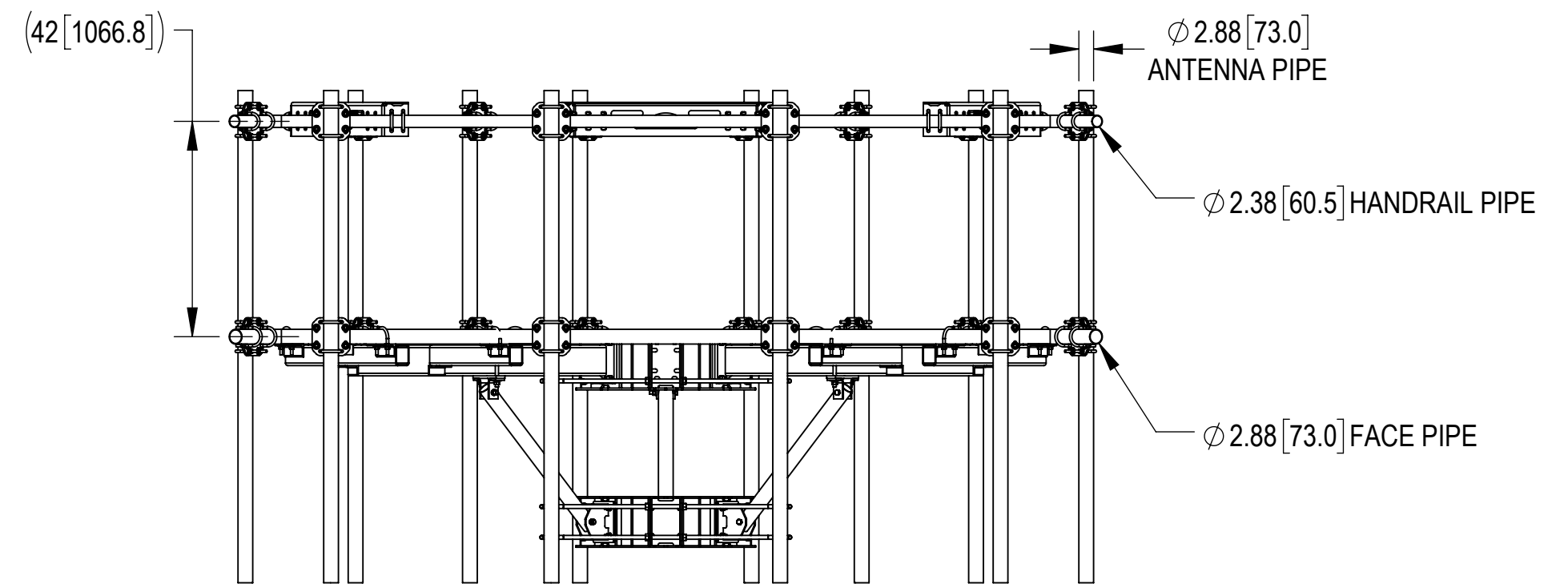
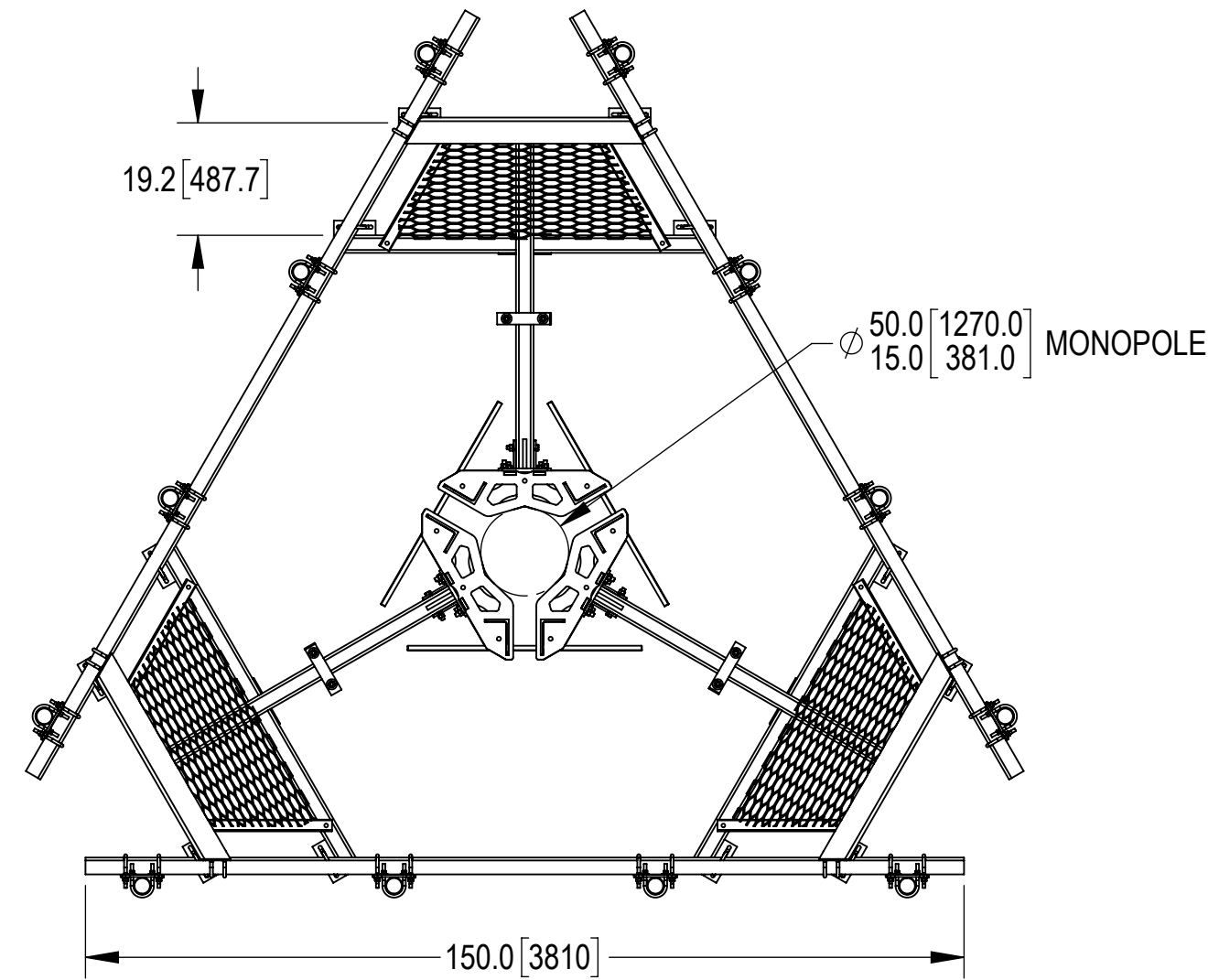

MONOPOLE LOW PROFILE PLATFORM
MC-HP12M-12-96-HD

COMMSCOPE, INC. OF NORTH CAROLINA										
TOLERANCES					SAP MATERIAL MASTER					
1 PLACE .X[X] ± 0.2[6.3]			3 PLACE .XXX[X] ± 0.060[1.5]		MC-HP12M-12-96-HD					
2 PLACE .XX[X] ± 0.12[3.0]			ANGLES ± 2°							
FINISH					MATERIAL					
UNLESS OTHERWISE SPECIFIED DIMENSIONS ARE IN INCHES INTERPRET PER ANSI Y 14.5M-1994	NAME	DATE	TITLE							
	CE LS1146	18SEP23	MP, 12', 3S, (12) 2.88" X 96" PIPE, W/HR							
	RW LS1146	11/02/2023								
	AD YW1045	11/02/2023								
	RE LS1146	11/02/2023								
ECN 40179365CMO										
SCALE	DOCUMENT NO.									
1:20	MC-HP12M-12-96-HD									
SIZE	Auth Group	INSL	MODEL			DRAWING				SHEET
C			VERSION	STATUS	REVISION	VERSION	STATUS	REVISION	1 OF 3	
			00	IW	A	00	RE	A		

DENSITY	1973.33	lbs/in ³
MASS	7661.83	lbs
VOLUME	77624.69	in ³
SURFACE AREA		in ²
HEIGHT		
LENGTH		
WIDTH		

4

3

2

1

PART NUMBERS, WEIGHTS, & EPA

TABLE 1: CONFIGURATIONS

PART NUMBER	DESCRIPTION	WEIGHT (LBS)	(EPA)A (FT^2)*	(EPA)A 1/2" ICE THICKNESS (FT^2)*	ANTENNA PIPES	INCLUDED PARTS									
						MC-RM1550-3	MC-AF-SB01	GUB-4355-12	MT197H	HRK-12-12-01	XP-2025-12	XP-2525-12	MT546150120	MT54696120	RK-36-3M
MC-HP12M-12-96-HD	MP,12',3S,(12)2.88"X96"PIPE,W/HR	1973.33	25.9	32.4	12	1	1	1	3	1	1	1	3	12	1

* (EPA)A DOES NOT INCLUDE ANTENNA PIPES AND MOUNTING HARDWARE. IF DESIRED, ADD ANTENNA PIPE PER TABLE 2

TABLE 2: EPA OF EACH ANTENNA PIPE

ANTENNA PIPE	(EPA)A (FT^2)	(EPA)A W/ 1/2" ICE THICKNESS (FT^2)
2-7/8" X 96"	1.84	2.48

NOTE:

1. ANTENNA PIPES ARE CONSIDERED SEPARATELY.
2. KA FACTOR OF 3-SECTOR EPA INCLUDED.
3. COMBINE THE ASSOCIATED EPA VALUES IN THE TABLES ABOVE TO DETERMINE THE EPA OF A MOUNT MODEL WITH A LISTED MOUNT PIPE CONFIGURATION. FOR EXAMPLE, MC-HP12M-12-96-HD HAS A 3-SECTOR EPA OF 25.9 FT2 WITH NO ICE PLUS 12 ANTENNA PIPES WITH A 3-SECTOR EPA OF 12X1.84=22.1 FT2 WITH NO ICE. SO, THE TOTAL EPA OF 48.0 FT2 FOR THE MC-HP12M-12-96-HD.

COMMSCOPE, INC. OF NORTH CAROLINA

TITLE
MP,12',3S,(12)2.88"X96"PIPE,W/HR

SIZE C	SCALE 1:20	DOCUMENT NO. MC-HP12M-12-96-HD
------------------	----------------------	-----------------------------------

	DRAWING			SHEET 2 OF 3
	VERSION 00	STATUS RE	REVISION A	

4

3

2

1

COMPOONENTS FOR INSTALLATION
MC-HP12M-12-96-HD SHOWN ON THIS PAGE

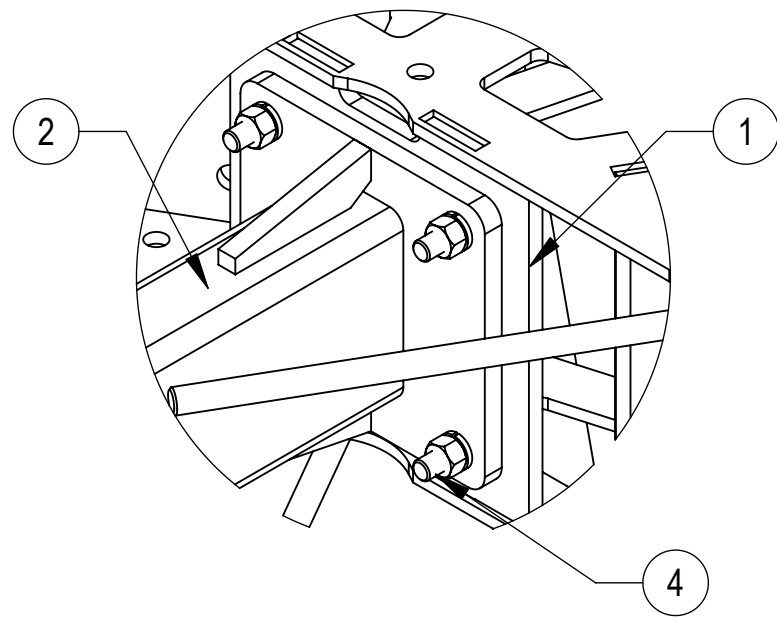

DETAIL A
SCALE 1 : 5

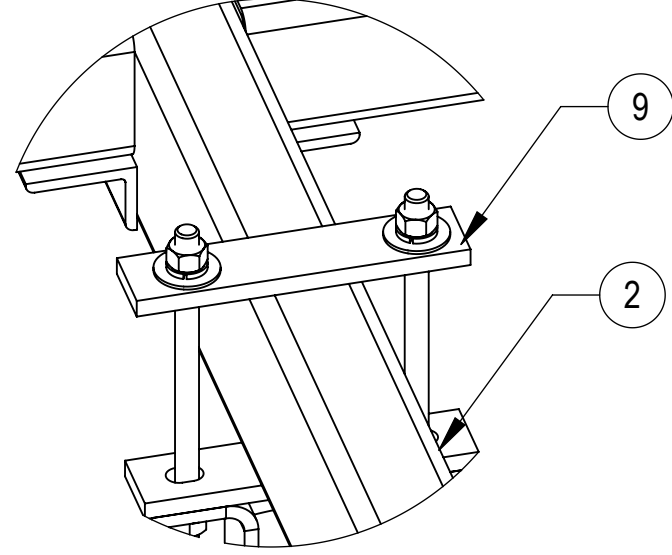

DETAIL B
SCALE 1 : 5

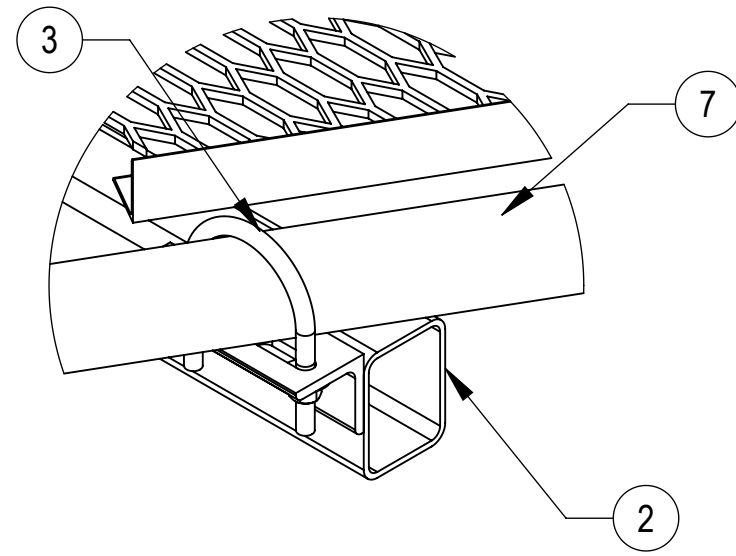

DETAIL C
SCALE 1 : 5

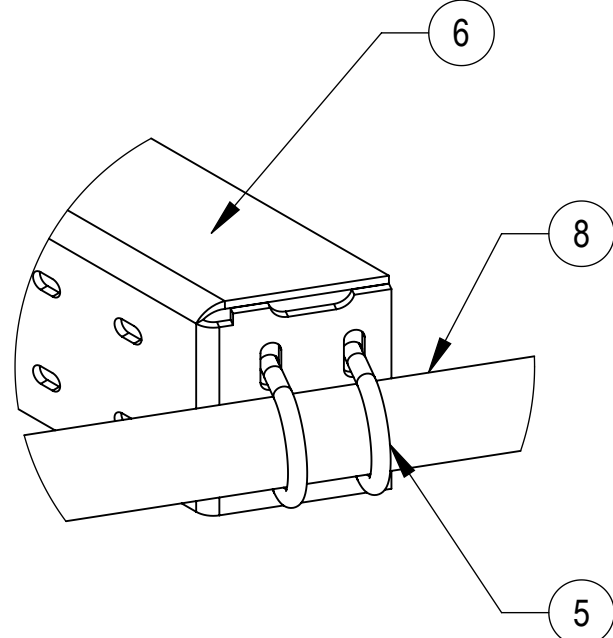

DETAIL D
SCALE 1 : 5

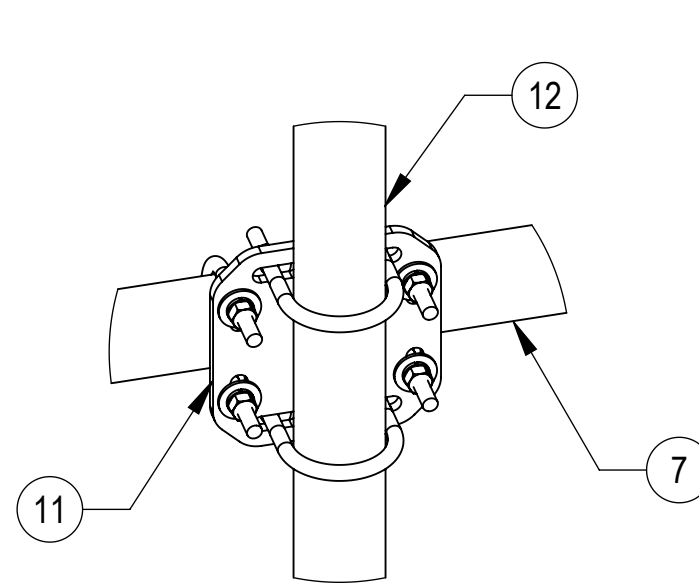
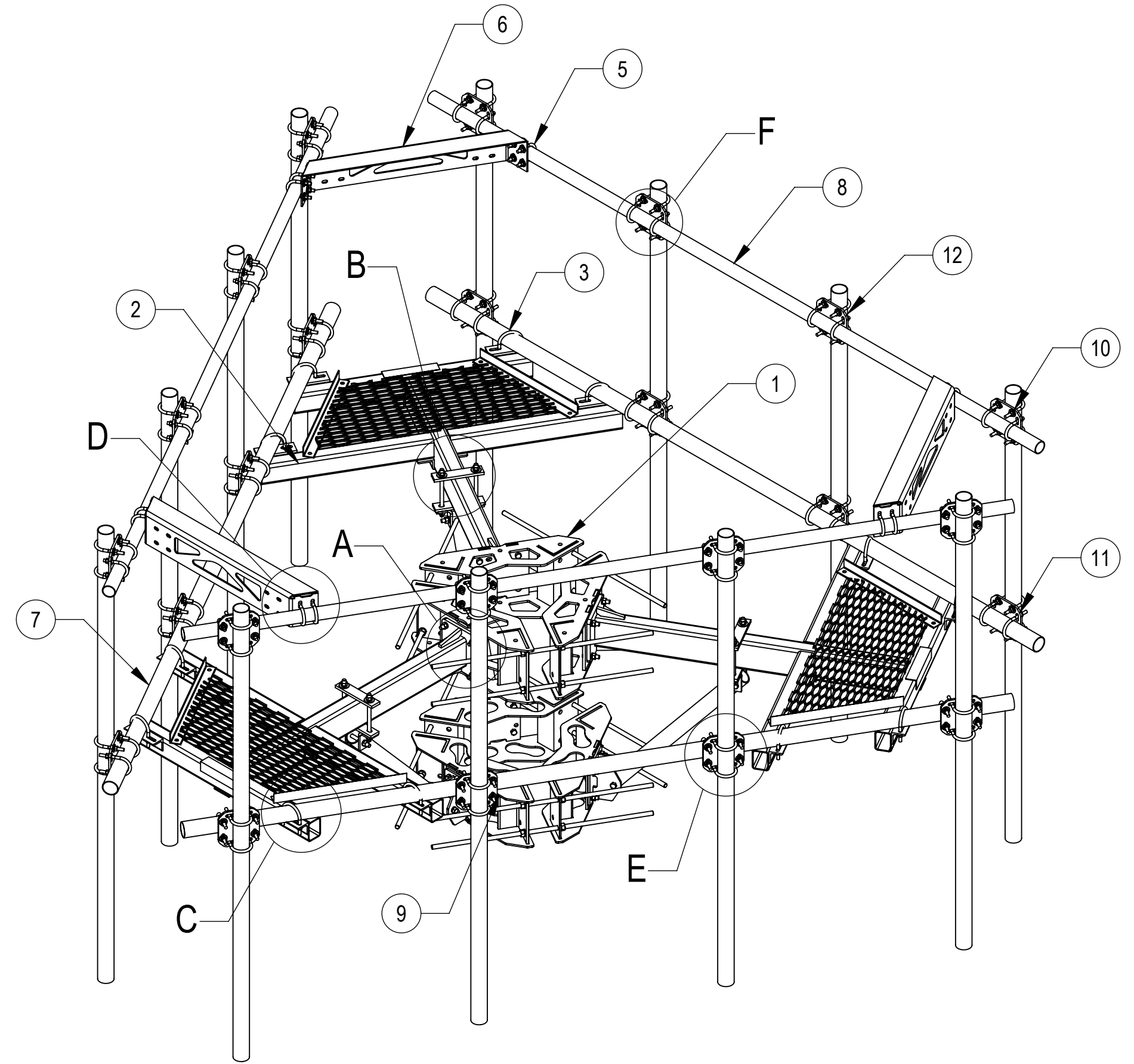

DETAIL E
SCALE 1 : 6

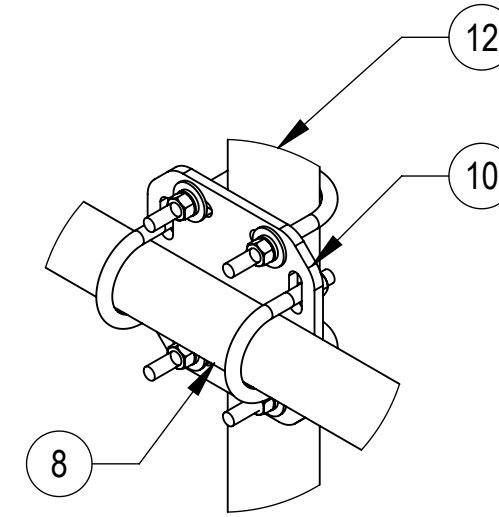

DETAIL F
SCALE 1 : 6

COMPONENT PART NUMBERS PROVIDED FOR ASSEMBLY PURPOSES;
INDIVIDUAL COMPONENTS MAY BE SHIPPED AS PARTS WITHIN AN INCLUDED KIT.

ITEM	PART NO.	DESCRIPTION	QTY.	WEIGHT	NOTE NO.
1	MC-RM1550-3	15" - 50" OD RINGMOUNT	1	229.90 LBS	
2	MC-AF-1100-00	WELDMENT, CO-LOCATION PLATFORM	3	184.88 LBS	
3	GUB-4355	1/2" X 3-5/8" X 5" GALV U-BOLT	12	0.71 LBS	
4	GB-0524A	5/8" X 2-1/2" GALV BOLT KIT (A325)	12	0.30 LBS	
5	GUB-4240	1/2" X 2-1/2" X 4" GALV U-BOLT	12	0.56 LBS	
6	MC-AF-2000-00	CORNER WELDMEMT, HANDRAIL	3	27.31 LBS	
7	MT546150120	2.88 OD X 150" LONG PIPE	3	44.29 LBS	
8	MT-651-150	2.375" OD X 150" PIPE	3	36.34 LBS	
9	RK-36-3M	REINFORCEMENT KIT, 3-SECTOR, 36" ARM, 15	1	302.78 LBS	
10	XP-2025	CROSSOVER PLATE KIT, 2-3/8 OD X 2-7/8 OD	12	7.77 LBS	
11	XP-2525	CROSSOVER PLATE KIT, 2-7/8 OD X 2-7/8 OD	12	8.07 LBS	
12	MT54696120	PIPE, 2.875"OD X 96"	12	28.35 LBS	

COMMSCOPE, INC. OF NORTH CAROLINA				
TITLE MP,12',3S,(12)2.88"X96"PIPE,W/HR				
SIZE C	SCALE 1:20	DOCUMENT NO. MC-HP12M-12-96-HD		
DRAWING		VERSION	STATUS	REVISION
		00	RE	A
				SHEET 3 OF 3