

# WT-HRM2-96

---



Water Tower Top Rail Mount, 2-3/8 in OD x 96 in plain end pipe included

## Product Classification

**Product Type** Water tower mount

## General Specifications

**Mounting** Handrail | Toe board

**Pipe, quantity** 1

## Dimensions

**Height** 2,438.4 mm | 96 in

**Width** 203.2 mm | 8 in

**Length** 609.6 mm | 24 in

**Pipe Length** 2,438.4 mm | 96 in

**Pipe Outer Diameter** 60.96 mm | 2.4 in

**Stand-off Distance** 228.6 mm | 9 in

# WT-HRM2-96

## Outline Drawing

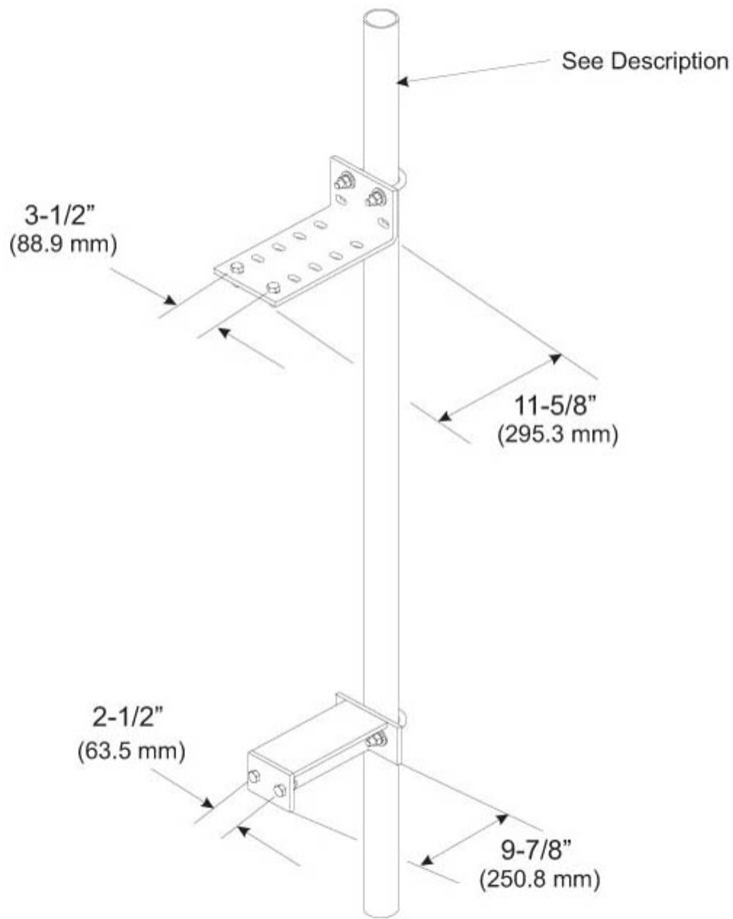

## Material Specifications

**Material Type** Hot dip galvanized steel

## Packaging and Weights

**Included** Hardware | Mount | Plain end pipes

**Packaging quantity** 1

**Weight, net** 22.407 kg | 49.4 lb

## Regulatory Compliance/Certifications

**Agency** **Classification**

# WT-HRM2-96

---

ISO 9001:2015

Designed, manufactured and/or distributed under this quality management system

## Included Products

- MT-651-96 – Plain End Pipe, 2-3/8 in OD x 96 in .120" A500C 46Ksi
- WT-HRM2-B – Water Tower Top Rail Mount for 2-3/8 in OD mounting pipe, plain end pipe not included

# MT-651-96

---



Plain End Pipe, 2-3/8 in OD x 96 in .120" A500C 46Ksi

## Product Classification

**Product Type** Plain end pipe

## General Specifications

**Pipe, quantity** 1

## Dimensions

**Height** 60.96 mm | 2.4 in

**Width** 60.96 mm | 2.4 in

**Length** 2,438.4 mm | 96 in

**Pipe Length** 2,438.4 mm | 96 in

**Pipe Outer Diameter** 60.325 mm | 2.375 in

**Material Thickness** 3.048 mm | 0.12 in

## Material Specifications

**Material Type** A500 | Hot dip galvanized steel

**Material Grade** C

**Material Strength** 46 KSI

## Packaging and Weights

**Included** Pipe

**Packaging quantity** 1

**Weight, net** 10 kg | 22.046 lb

## Regulatory Compliance/Certifications

### Agency

CHINA-ROHS

ISO 9001:2015

### Classification

Above maximum concentration value

Designed, manufactured and/or distributed under this quality management system

# MT-651-96

---

ROHS Compliant/Exempted

UK-ROHS Compliant/Exempted



# WT-HRM2-B

---



Water Tower Top Rail Mount for 2-3/8 in OD mounting pipe, plain end pipe not included



## Product Classification

**Product Type** Water tower mount

## General Specifications

**Mounting** Handrail | Toe board

**Pipe, quantity** 0

## Dimensions

**Height** 889 mm | 35 in

**Width** 203.2 mm | 8 in

**Length** 609.6 mm | 24 in

**Pipe Outer Diameter** 60.96 mm | 2.4 in

**Stand-off Distance** 228.6 mm | 9 in

# WT-HRM2-B

## Outline Drawing

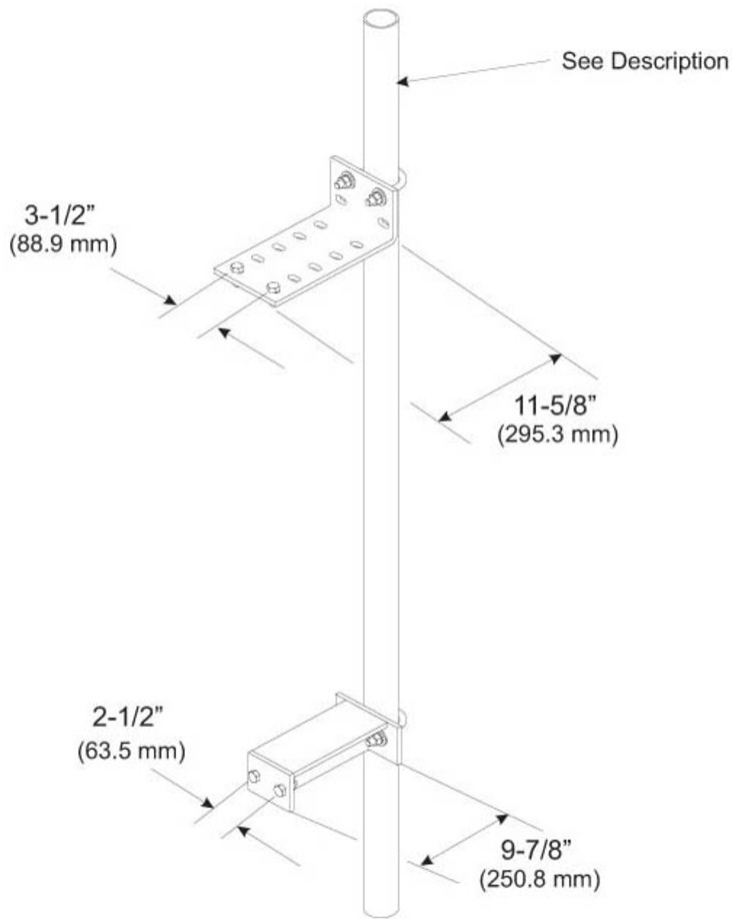

## Material Specifications

**Material Type** Hot dip galvanized steel

## Packaging and Weights

**Included** Hardware | Mount

**Packaging quantity** 1

**Weight, net** 9.299 kg | 20.5 lb

## Regulatory Compliance/Certifications

**Agency** **Classification**

# WT-HRM2-B

---

CHINA-ROHS	Below maximum concentration value
ISO 9001:2015	Designed, manufactured and/or distributed under this quality management system
REACH-SVHC	Compliant as per SVHC revision on <a href="http://www.andrew.com/ProductCompliance">www.andrew.com/ProductCompliance</a>
ROHS	Compliant
UK-ROHS	Compliant

